

**Product Description**

RFMD's SBB-1000 is a high performance InGaP HBT MMIC amplifier utilizing a Darlington configuration with an active bias network. The active bias network provides stable current over temperature and process Beta variations. Its efficient operation from a single 5V supply and its compact size (0.59mmx0.70mm) make it ideal for high-density multi-chip module applications. It is well-suited for high linearity 5V gain block applications and it is internally matched to 50Ω.

RFMD can provide 100% DC screening, visual inspection, and Hi-Rel wafer qualification. Die can be delivered at the wafer level or picked to gel or waffle paks.

**Features**

- OIP3=42dBm @ 250MHz
- P1dB=20dBm @ 500MHz
- Single Fixed 5V Supply
- Compact Die Size (0.59mmx0.70mm)
- Patented Thermal Design and Bias Circuit
- Low Thermal Resistance

**Applications**

- PA Driver Amp
- RF Pre-driver and RF Receive Path
- Military Communications
- Test and Instrumentation

**Optimum Technology Matching® Applied**

- GaAs HBT
- GaAs MESFET
- InGaP HBT
- SiGe BiCMOS
- Si BiCMOS
- SiGe HBT
- GaAs pHEMT
- Si CMOS
- Si BJT
- GaN HEMT
- RF MEMS

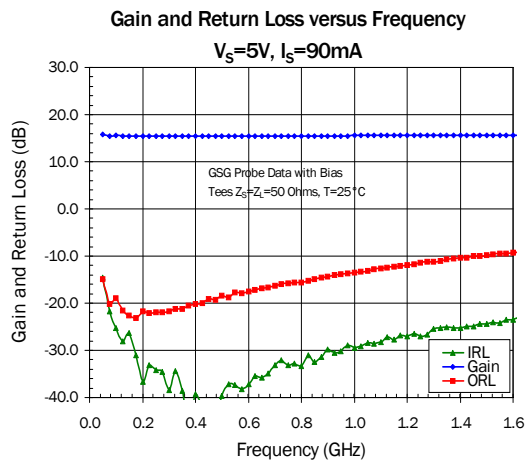

Parameter	Specification			Unit	Condition
	Min.	Typ.	Max.		
Frequency of Operation	50		1000	MHz	
Small Signal Gain		15.5		dB	Freq=250MHz, 500MHz, 1000MHz
Output Power at 1dB Compression		21.5		dBm	Freq=250MHz
		20.0		dBm	Freq=500MHz
		19.0		dBm	Freq=1000MHz
Output IP <sub>3</sub>		42.0		dBm	Freq=250MHz
		40.5		dBm	Freq=500MHz
		35.5		dBm	Freq=1000MHz
Input Return Loss		>25		dB	Freq=500MHz
Output Return Loss		18.5		dB	Freq=500MHz
Current		90		mA	
Noise Figure		3.4		dB	Freq=500MHz
Thermal Resistance		48.8		°C/W	Junction to lead (89 pkg)

Test Conditions: Z<sub>0</sub>=50Ω, V<sub>D</sub>=5V, I<sub>D</sub>=90mA, T=25°C, OIP3 Tone Spacing=1MHz, P<sub>OUT</sub>/tone=0dBm. GSG Probe Data with Bias Tees.

## Absolute Maximum Ratings

Parameter	Rating	Unit
Total Current ( $I_D$ )	110	mA
Device Voltage ( $V_D$ )	5.5	V
Power Dissipation	0.61	W
Operating Lead Temperature ( $T_L$ )	-40 to +85	°C
RF Input Power	+12(TBR)*	dBm
Storage Temperature Range	-55 to +150	°C
Operating Junction Temp ( $T_J$ )	+150	°C
ESD Rating - Human Body Model (HBM)	Class 1C	



Caution! ESD sensitive device.

Exceeding any one or a combination of the Absolute Maximum Rating conditions may cause permanent damage to the device. Extended application of Absolute Maximum Rating conditions to the device may reduce device reliability. Specified typical performance or functional operation of the device under Absolute Maximum Rating conditions is not implied.

RoHS status based on EU Directive 2002/95/EC (at time of this document revision).

The information in this publication is believed to be accurate and reliable. However, no responsibility is assumed by RF Micro Devices, Inc. ("RFMD") for its use, nor for any infringement of patents, or other rights of third parties, resulting from its use. No license is granted by implication or otherwise under any patent or patent rights of RFMD. RFMD reserves the right to change component circuitry, recommended application circuitry and specifications at any time without prior notice.

\* TBR=To Be Reviewed

Operation of this device beyond any one of these limits may cause permanent damage. For reliable continuous operation, the device voltage and current must not exceed the maximum operating values specified in the table on page one.

Bias Conditions should also satisfy the following expression:

$$I_D V_D < (T_J - T_L) / R_{TH, j}$$

## Typical Performance (GSG Probe Data with Bias Tees) $V_D = 5V$ , $I_D = 90mA$ , $T = 25^\circ C$ , $Z = 50\Omega$

Parameter	Units	50 MHz	100 MHz	250 MHz	500 MHz	750 MHz	1000 MHz
Small Signal Gain	dB	15.8	15.6	15.5	15.5	15.5	15.5
Output 3rd Order Intercept Point (see note 1)	dBm			42.0	40.5	38.0	35.5
Output Power at 1dB Compression	dBm			21.5	20.0	19.5	19.0
Input Return Loss	dB	17.0	24.0	34.0	38.0	32.0	29.0
Output Return Loss	dB	15.0	19.0	21.5	18.5	15.5	13.5
Reverse Isolation	dB	17.0	18.0	18.5	18.0	18.0	18.0
Noise Figure	dB	3.4		3.4	3.4	3.6	3.6

Note 1: 0dBm/tone, 1MHz spacing.

Typical Performance (GSG Probe Data with Bias Tees)  $V_D=5.0V$ ,  $I_D=90mA$

**P1dB versus Frequency**

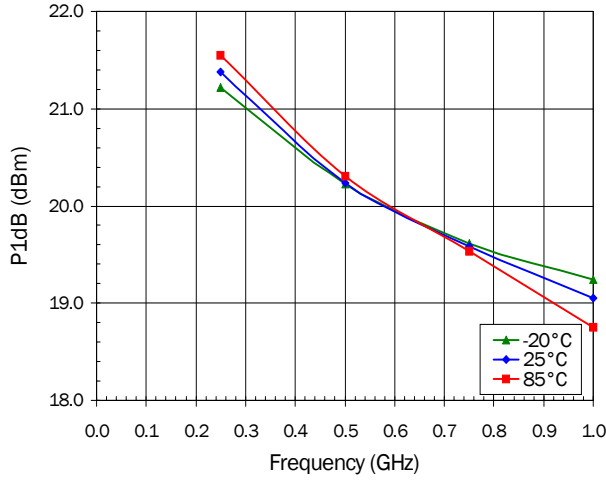

**OIP3 versus Frequency**  
(0dBm/tone, 1MHz spacing)

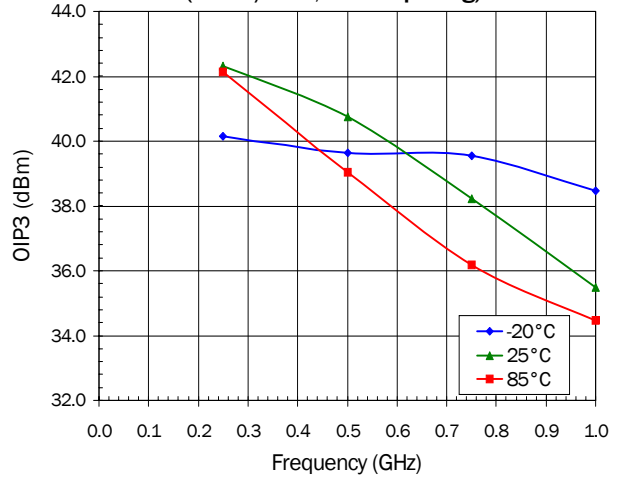

**Current versus Voltage**

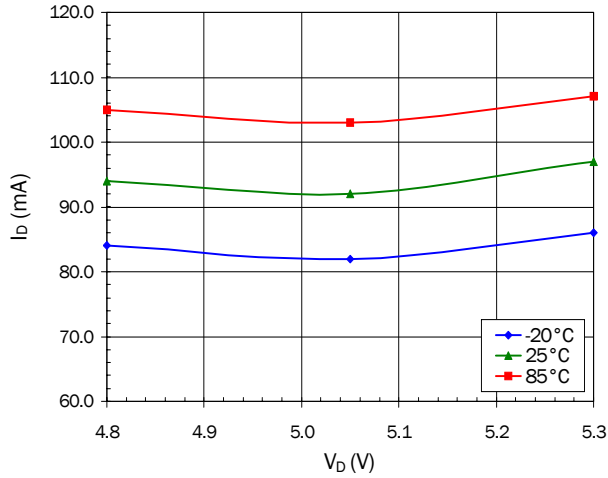

**Noise Figure versus Frequency**

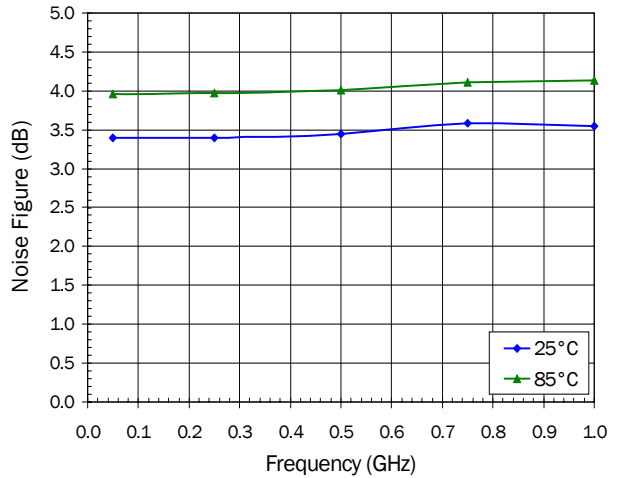

Typical Performance (GSG Probe Data with Bias Tees)  $V_D = 5.0V$ ,  $I_D = 90mA$

### S11 versus Frequency

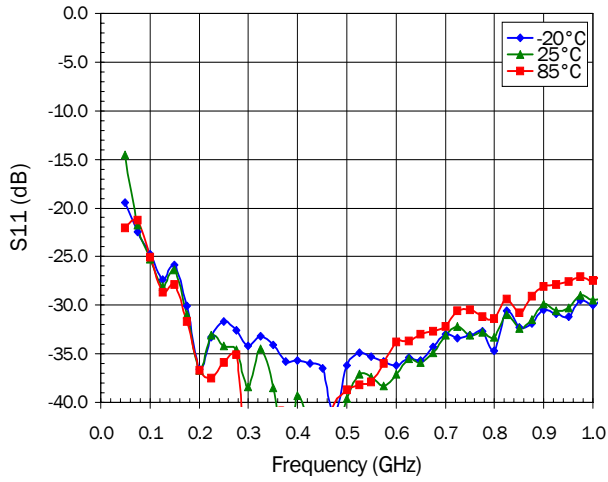

### S21 versus Frequency

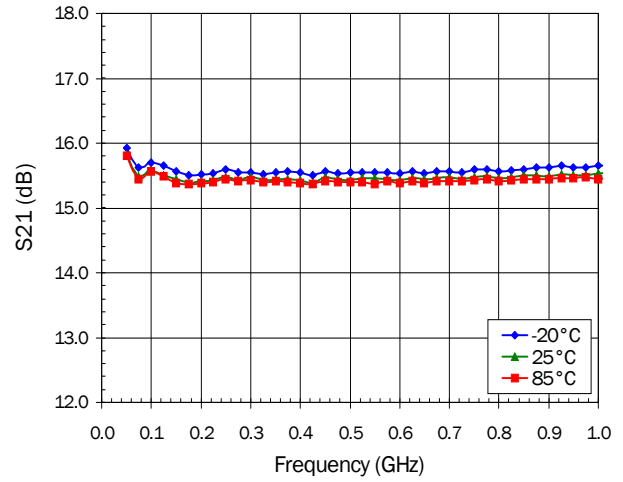

### S12 versus Frequency

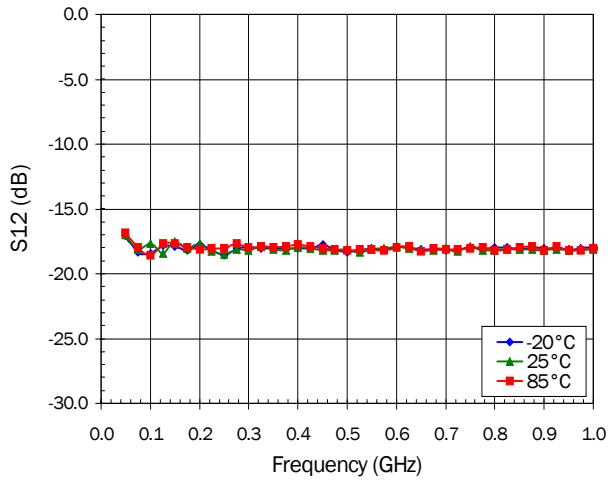

### S22 versus Frequency

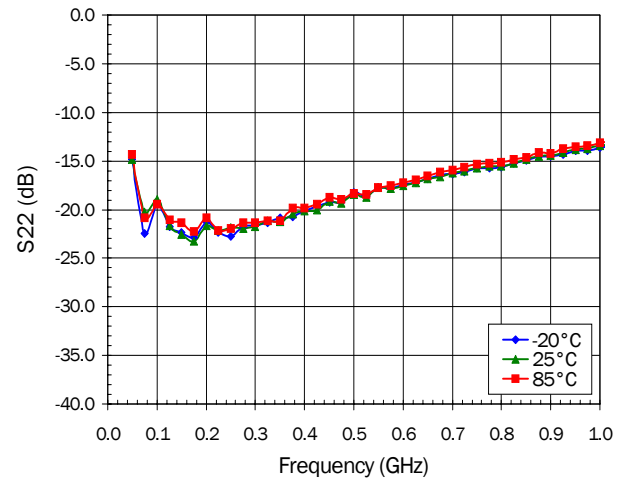

**Die Dimensions**

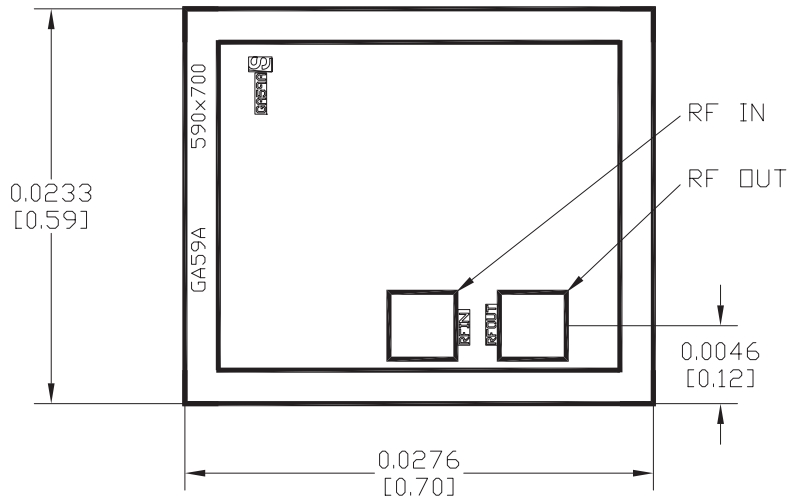

**Bond Pad Description**

Bond Pad	Function/Description
RF IN	This pad is DC coupled and matched to 50Ω. An external DC block is required.
RF OUT	This pad is DC coupled and matched to 50Ω. DC bias is applied through this pad.
DIE BACKSIDE	Die backside must be connected to RF/DC ground using silver filled conductive epoxy.

Notes:

1. All dimensions in inches [millimeters].
2. Die Thickness is 0.004 [0.100].
3. Typical bond pad is 0.004 (0.100) square.
4. Backside metallization: Gold.
5. Bond pad metallization: Gold.
6. Backside is ground.

**Device Assembly**

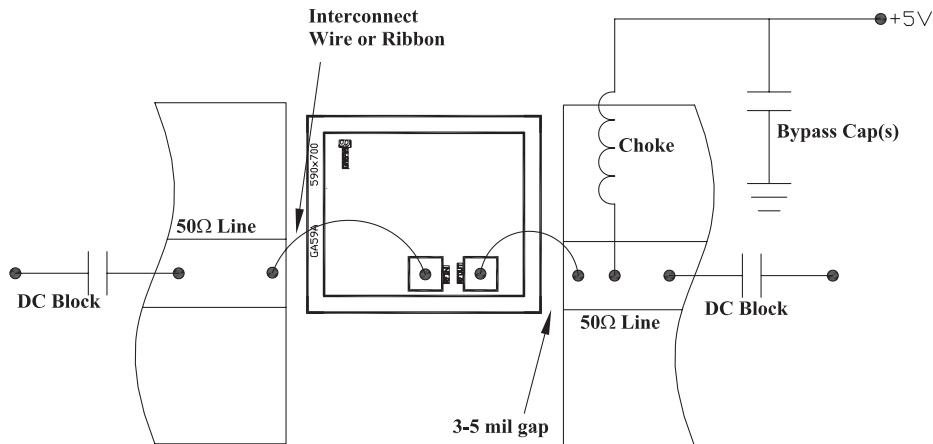

**Ordering Information**

Part Number	Description	Devices/Container
SBB-1000	Bare Die	

# SBB-1000

*Preliminary*



rfmd.com