

OBSOLETE PRODUCT

Contact Factory for Replacement Model

FEATURES

- Micro-bussable meter provides BCD data outputs for compatibility with microprocessors.
- BCD data out is 3-state-gated, to share bus with other devices.
- Data gated in 4-bit groups for use with 4-, 8-, 12-, or 16-bit data bus widths.
- Full parallel output selectable.
- "Data Ready" output pulse is ideal for interrupt or print command.
- DPM has super high impedance (1000 megohms), super low bias current (5 pA), differential in.
- Ultra-compact, low profile case—2.53"W x 3.34"D x 0.94"H (64,3 x 84,8 x 23,8 mm)
- 5V powered @ 450 mA
- Bright 0.39" H LED digits
- Autozeroed, ratlometric,
- Low Cost

APPLICATIONS

- **Signal Monitor and A/D**—Use meter to monitor voltage, current, temp; BCD outputs permit CPU control or printout.
- **Data Logger**—Simple interconnection with Datel-Intersil's DPP-Q7 Thermal Printer
- **Ammeter**—Accepts user-supplied shunts for $\pm 20 \mu\text{A}$ to $\pm 2\text{A}$ Full Scale Ranges.
- **Voltmeter**—Accepts user-supplied attenuators for $\pm 2\text{V}$ to $\pm 1\text{kV}$ Full Scale Ranges.

DESCRIPTION

The DM-4101D combines full 4½ digit DPM performance with 3-state BCD outputs, an ultra-compact size, and a very low price. The meter has differential analog inputs which are both ultra high in impedance (1000 megohms) and ultra low in bias current (5 picoamperes)—the DM-4101D will not load down sensitive input signals. The unit is accurate to within .02% FSR (± 2 counts). Input circuitry is autozeroed on each conversion cycle to reduce zero drift. All this performance has been packed into a low-profile black polycarbonate case only 2.53" wide x 3.34" deep x 0.94" high (64,3 x 84,8 x 23,8 mm). The price of the meter is small as well: it costs no more than many less sophisticated, display-only DPM's.

The DM-4101D's 3-state BCD outputs take it beyond many so-called "microprocessor compatible" DPM's. 3-state outputs mean that the meter can be connected directly to a microcomputer's data bus. They also permit multiple DM-4101D's to be daisy-chained to a single set of computer or printer input



Note: DPM's are normally supplied without Bezel Labels or Logos

connections—the computer inputs "see" only those meter outputs which have been enabled. And, since each 4-bit group (corresponding to a single BCD-encoded numeral) may be gated separately, a single rear-panel change makes the DM-4101D compatible with processors using 4-, 8-, 12-, or 16-bit data words. Digital outputs for the Display Polarity Underrange, Out of Range, E.O.C., "Data Ready" (a 10 μsec pulse occurring 10 μsec after the digital data is valid), and meter Run/Hold status make microcomputer control of the meter possible with minimal external hardware. Sufficient control circuitry is already built into the DM-4101D that it can interface directly with Datel-Intersil's DPP-Q7 thermal printer (or a similar printer) to become a functional data logger.

The DM-4101D input CMOS circuitry can safely handle over-voltages to $\pm 250\text{Vdc}$. The meter's converter board contains blank circuit pads to accept input attenuation resistors or current shunts. Temperature drift of the autozeroed input amplifier is ± 1 count from 0 to $+50^\circ\text{C}$. Temperature drift of gain measures ± 50 ppm of FSR/ $^\circ\text{C}$ (typical) and ± 100 ppm of FSR/ $^\circ\text{C}$ maximum.

The DM-4101D uses a dual slope integrating converter which provides normal mode rejection of AC power line noise. It provides an input-to-output conversion linearity to within $\pm .02\%$ of reading ± 2 counts. The standard sampling rate is 3 conversions per second.

Power to the meter is $+5\text{Vdc}$ @ 380 mA typical (450 mA max), and may be supplied directly from a microcomputer bus. A built-in dc-dc converter (to power the meter's analog input circuitry) provides $\pm 5\text{Vdc} \pm 5\%$ (@ $\pm 15\text{mA}$ max.) to power user-supplied circuitry. The $\pm 5\text{V}$ output was specifically intended to power an external instrumentation or CAZ amp, to provide the DM-4101D with a differential analog input. Datel-Intersil's UPA-5/500, 5V @ .5A AC power supply is available as an accessory.

IN THIS DATA SHEET

Page 2 & 3	Specifications
Page 3	Ordering Information
Page 4	Outline Dimensions Panel Mounting Block Diagram
Page 5	Input-Output Connections Component Locations Other Voltage and Current Ranges
Page 6	DM-4101D Interface with DPP-Q7 Thermal Printer Differential Input Decimal Point Wiring Timing Diagram
Page 7	Applications Introduction DM-4101D Bus Interface
Page 8	Bus Interface Block Diagram Motorola 6800/6502 P.I.A. Interface

SPECIFICATIONS, DM-4101D
(typical @ -25°C, unless noted)

ANALOG INPUT

Configuration and full scale input range	Differential bipolar; -1.9999 Vdc to +1.9999 Vdc Input pad area will accept user-installed range change.
Input Bias Current	5 pA typical, 50 pA maximum
Displayed Accuracy @ +25°C	Adjustable to ±0.02% of reading, ±2 counts
Resolution	100 µV in Least Significant Digit
Temperature Drift of Zero	Autozeroed; ±1 count over 0 to +50°C
Temperature Drift of Gain	± 50 ppm of Reading/°C typical ±100ppm of Reading/°C maximum
Input Impedance	1000 megohms, typical, 100 megohms, minimum
Input Overvoltage	±250 Volts dc, 155 VRMS continuous max. ±300 Volts intermittent max.
Warm-Up Time	Within 10 minutes
Reference	Internal, referred to Power Common. External, user-supplied reference optional for ratiometric operation.
External Ref. Range	+100 mV to +2V, referred to Analog Common
Common Mode Voltage Range	± 2V max to power gnd.
Common Mode Rejection Ratio80dB typ.

DISPLAY

Number of Digits	4 decimal digits and most significant "1" digit (4½ digits)
Decimal Points	Selectable decimal points are included for scale multipliers.
Display Type	Red, light-emitting diode (LED), self-illuminated
Display Height	0.39" (9.9 mm)
Overscale	Inputs exceeding the full scale range cause the display to blink
Autopolarity	A polarity sign is automatically displayed for bipolar inputs, and may be disabled.
Sampling Rate	Typically 3 conversions per second.

NOTE: The DM-4101D's display is not latched; the display may not track the meter's BCD data out.

I/O CONNECTIONS

J2 ANALOG CONNECTOR (LOWER)

Reference In (Pin B1)/ Reference Out (Pin A1)	Normally REFERENCE IN and REFERENCE OUT should be jumpered together. An external high quality reference, grounded to ANALOG COMMON may be connected to REFERENCE IN or used for ratiometric applications.
Analog Common (Pin A2)	ANALOG COMMON is not internally connected to POWER COMMON, but <i>must</i> be connected externally. An external bias current path between <i>both</i> inputs and pin A2 must be supplied by the user to stay within CMV range.
Analog LO Input (Pin B2) / Analog HI Input (Pin B5)	Signal input Normal voltage range is -1.9999 to +1.9999 Vdc, but an internal attenuator or current shunt resistors may be installed (R1 and R2)
Display Test Input (Pin A7)	Connect this to POWER COMMON, displays 18888 to test display segments.
Decimal Points (Pins A8 to A11)	Connect selected pin to DECIMAL POINT COMMON (Pin A12). Do not connect D.P. to POWER COMMON as this will destroy D.P.
Polarity Enable Input (Pin B8)	Ground to POWER COMMON (Pin A14) to enable +/- sign on display.

+5V In (Pin B14)	Power input to the meter; connections made between +5V IN and POWER COMMON (pins J1-A14 and B13 and J2-B14); requires regulated supply (± 5%), capable of supplying 450 mA max.
Display Enable Input (Pin B15) (Not a Logic Input)	Connect to +5V (B14) to enable all display segments and decimal points. (Disabling display reduces power consumption to 250 mA, typically).
Power Common (Pins A14/B13)	Power supply common must be connected externally to ANALOG COMMON.
+5Vout (Pin B12) / -5Vout (Pin B11)	These voltage outputs provide +1A and -15 mA respectively to power user-supplied external circuitry. May be used to power an instrumentation or C.A.Z. amplifier. Caution: these outputs are <i>not</i> short-circuit-proof. Shorting either of them to ground, or drawing more than the ± 15 mA specified, can damage the meter's DC-DC converter.
Pins A3 to A6; A13, A15; B3, B4, B6, B7, B9, B10	No internal connection

SPECIFICATIONS (Cont'd):

I/O CONNECTIONS (Cont'd)

J1 DATA CONNECTOR (UPPER)

Digit Enable Input These are active high, and operate on data in groups of 4 bits (e.g., Enable 10's controls BCD 10, 20, 40 and 80; Enable 100's controls BCD 10,000 (overrange), PLUS/MINUS, OUT OF RANGE, and UNDERRANGE. For full parallel output, all Enables should be left open or connected to +5V. 74LS295 are used as latches, and timing is as specified for these devices.

Run/Hold Input (Pin B13) When open or high the D.P.M. will run continuously at its maximum rate (3 readings/second). When low, the D.P.M. will hold a reading after completion of any conversion in process. Momentarily bringing the RUN/HOLD high (for a minimum of 300 μS) will initiate a conversion, after which the D.P.M. will remain in hold until receipt of another RUN/HOLD pulse. This provides a means of externally triggering the D.P.M.

BCD Data Outputs 1,2,4,8 (and 10,20,40,80, etc) BCD data is fully latched. Outputs are 3-state and controlled in groups of 4. Outputs are DTL/TTL compatible, positive true, and sink 4.0 mA @ 0.4V (2½ TTL loads).

BCD 1 (Pin A2), 2 (Pin A3), 4 (Pin A4), 8 (Pin A5)

BCD 10 (Pin A7), 20 (Pin A8), 40 (Pin A9), 80 (Pin A10)

BCD 100 (Pin B2), 200 (Pin B3), 400 (Pin B4), 800 (Pin B5)

BCD 1000 (Pin B7), 2000 (Pin B8), 4000 (Pin B9), 8000 (Pin B10)

BCD 10,000 (Pin A12)

Plus/Minus Polarity Out (Pin A13) This is true for positive input. 3-state latch enabled by pin A11

Out of Range Output (Pin A14) This is true when reading is greater than +1.9999 Vdc or less than -1.9999 Vdc. 3-state latch enabled by pin A11.

Underrange Output (Pin A15) This is true when the magnitude of the reading is less than 1800. OUT OF RANGE and OVERRANGE may be used to drive auto-ranging circuitry external to the D.P.M. Three-state latch enabled by pin A11.

E.O.C. Output (Pin B11) The E.O.C. output is high during a conversion (fan out 2½ TTL loads).

Data Ready (Pin B12) The DATA READY is a short pulse (10 μS) which is produced 10 μS after the data is valid in the D.P.M. latches. It may be used to trigger a printer, to load external latches, or to interrupt a computer.

+5V (Pin B14) and Digital Common (Pin B15) Pin B15 is internally connected to J2-A14/B13, Pin J1-B14 (+5V) must be externally connected to +5V (J2-B14).

BCD OUTPUT

Format BCD outputs 3-state, gateable in 4-bit groups, full parallel output available.

Fanout 2½ TTL loads

Logic Controls E.O.C. pulse, "Data Ready" (Print Pulse), Overage, Underrange, Out of Range, PLUS/MINUS Polarity OUT, and RUN/HOLD.

Calibration A multiturn screwdriver pot (rear-panel mounted) adjusts the full scale reading (gain). Zero is automatic (autozeroed). Suggested recalibration in stable conditions is 90 days.

PHYSICAL-ENVIRONMENTAL

Low-Profile Case Interchangeable with other Datel-Intersil cases.

Outline Dimensions 2.53"W x 3.34"D x 0.94"H (64,3 x 84,8 x 23,8 mm)

Cutout Dimensions 2.562"W x 0.969"H (minimum) (65,1 x 24,6 mm)

Mounting Method Through a front panel cutout secured by brackets and two removable side case screws. Panel thickness 0.62" (15,9 mm).

Weight 4.1 oz (116 grams)

Connectors (2 Required) Dual 15 pin, 0.1" centers. Datel-Intersil #58-2073083

Mounting Position Any

Operating Temperature Range 0 to +50° C

Storage Temperature Range -25 to +85° C

Altitude 0 to 15,000 feet (4600m)

Relative Humidity 20% to 80%, non-condensing

ORDERING INFORMATION

MODEL	DESCRIPTION
DM-4101D	Micro-bussable 4½ Digit DPM
UPA-5/500	115 VAC-to-5 Vdc Power Adapter
58-2073083	Dual 15-pin connector, .100" ctrs., solder-tabs (not included with meter, 2 required)

PANEL MOUNTING

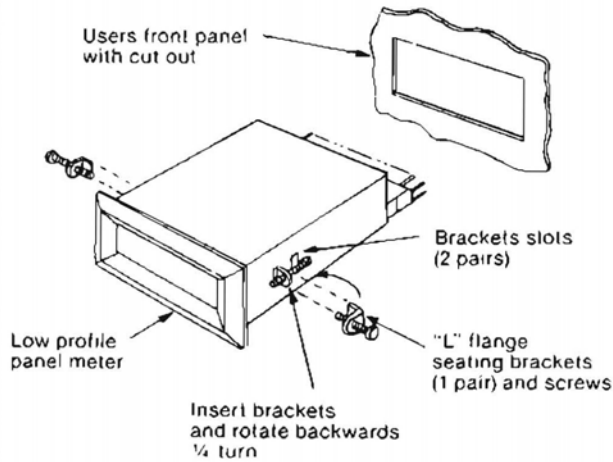

OUTLINE DIMENSIONS

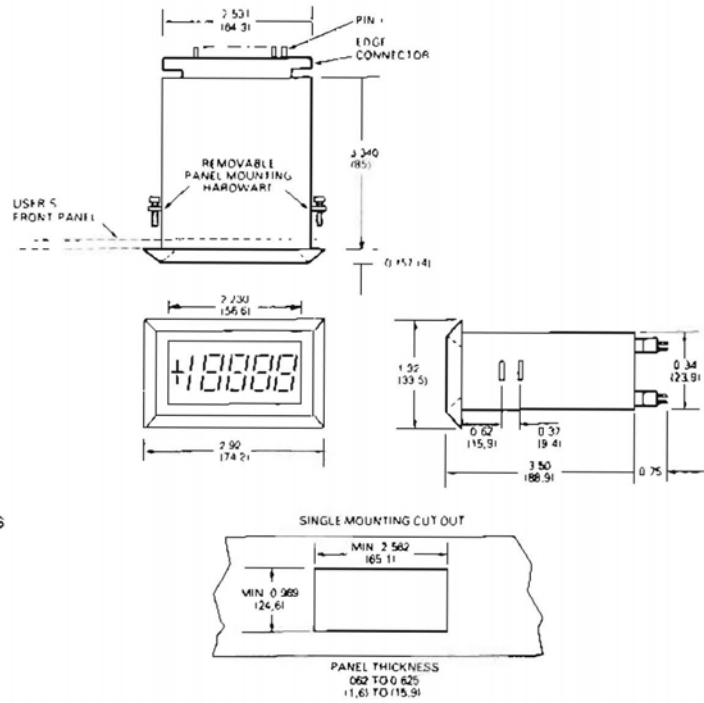

INCHES (MM)

BLOCK DIAGRAM

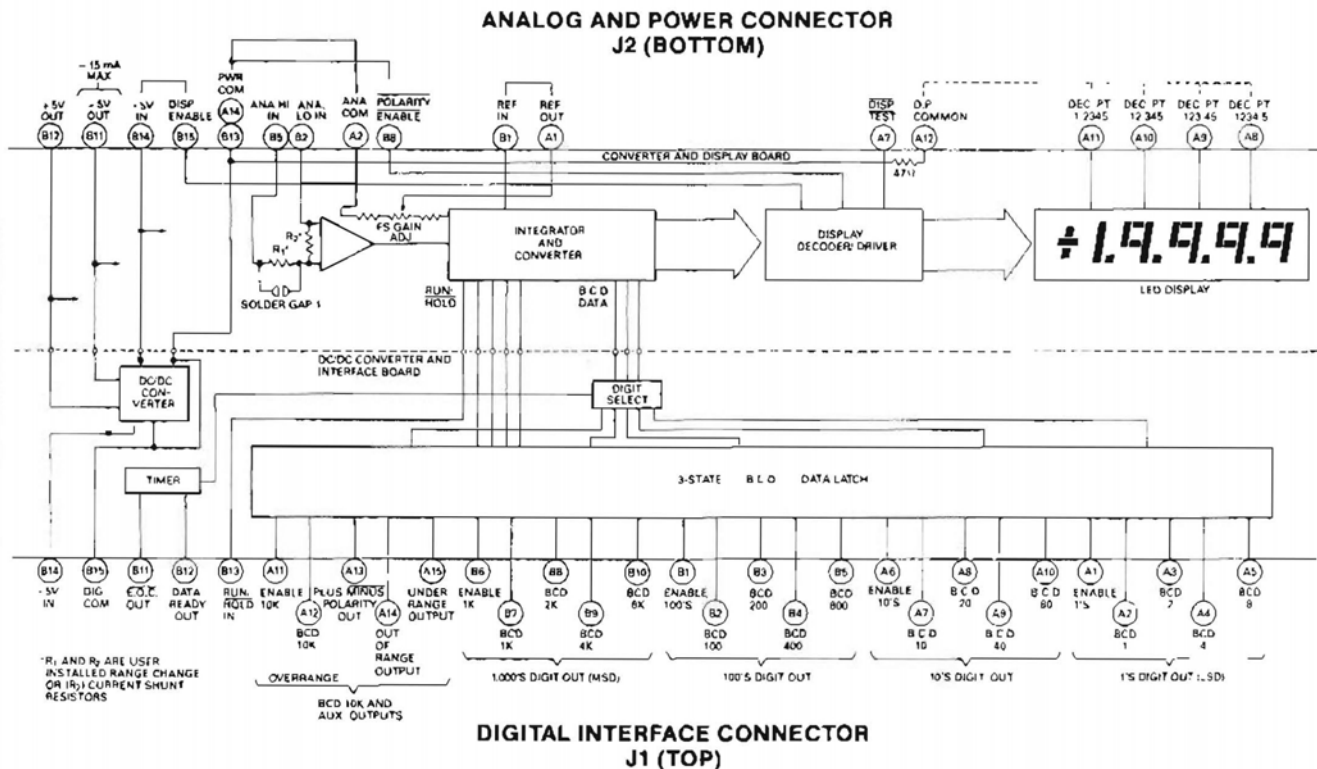

DM-4101D INPUT-OUTPUT CONNECTIONS (REAR VIEW)

(This view shows DPM turned on its side.)

**BOTTOM BOARD (J2)
ANALOG AND POWER CONNECTOR**

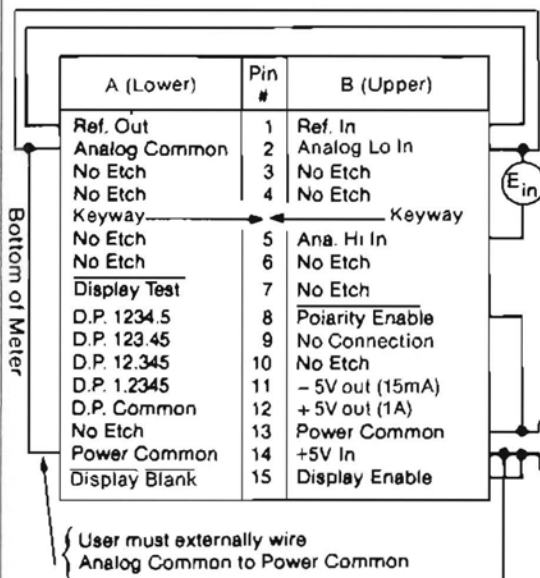

**TOP BOARD (J1)
DIGITAL INTERFACE CONNECTOR**

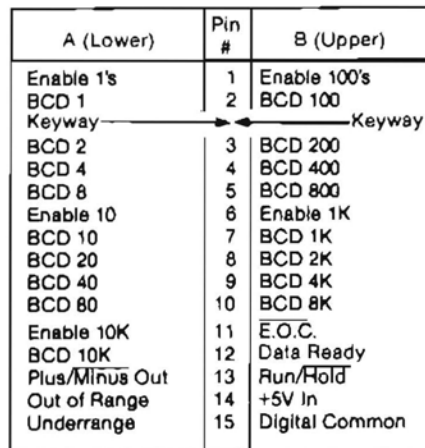

CAUTION: CMOS Inputs.
Avoid damage from static discharge.
Handle only with ground protection.

Normal External Connections Are Shown

- NOTES:**
1. All BCD outputs are 3-state, enabled high, and can drive 2½ TTL loads. 74LS295 3-state latches are used.
 2. -5V is 15 mA max. and is not current limited. Sustained overloads or short circuits can result in damage to the meter's DC-DC converter.

DM-4100D COMPARISON TO DM-4101D

	DM-4100D	DM-4101D
1. Input type	Single-ended	Differential, CMV ± 2V max to power ground (non-isolated). CMR 80dB typ.
2. Power for optional external signal-conditioners	+ 13.5V @ 20mA max - 13.5V @ 20mA max	+ 5V @ 1A max (no reflected spikes). - 5V @ 15mA max (may require external filtering)
3. +5V power input	580mA max	± 5V power out current must be added to the DM-4101D + 5V power input. 450 mA max (if additional ± 5 power output is used, this current must be added to the above figure).
4. Display size	0.3 inches high	0.39 inches high
5. Pinout differences	J2-B2: Analog Common (signal ground) J2-B12: + 13.5Vdc out J2-B11: - 13.5Vdc out J1-B14: + 5Vdc power is internally connected (no external connection is required) J2-A15: No connection	J2-B2: Analog LO In (Differential Inverting Input). J2-A2 is retained as Analog Common J2-B12: + 5Vdc out J2-B11: - 5Vdc out J1-B14: + 5Vdc power must be externally connected. J2-A15: Display Blank. Pin open or logic H1: Display lights. Pin logic LO: Display blanks (Pin includes an internal pullup resistor to + 5V). J2-B15 must still be externally connected to power the display. With J2-B15 open, the A/D converter stays running for low drift.
	J2-B9: 3½/4½ Mode	J2-B9: No Connection

DM-4101D INTERFACE WITH DPP-Q7 THERMAL PRINTER

The DM-4101D may be connected directly to Datal-Intersil's DPP-Q7 Miniature Printer to form a functional data logger. The required connections are shown below.

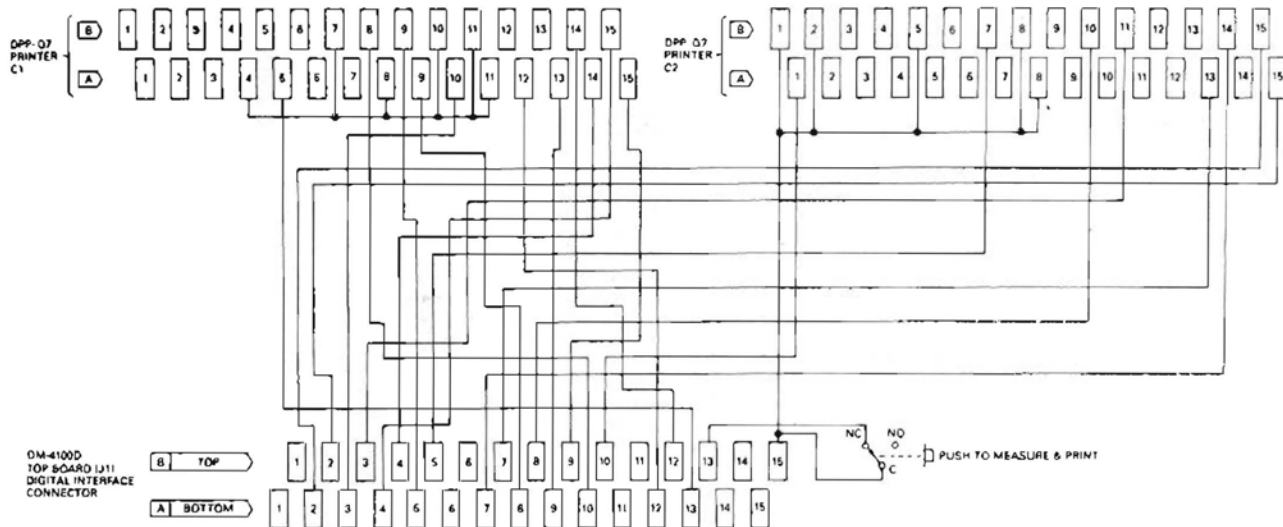

Notes:

1. Leading zero suppression on the printer may be activated by grounding printer pin B4 on connector C1 (join B4 to A4 on C1).
2. To select the desired decimal point on the printer, ground all unused decimal points to C1 pin A4. Only the unconnected decimal point is enabled.
3. The Run/Hold input on the D.P.M. can be used to trigger a Measure/Print cycle. A logic input or contact opening can be used (no debounce is necessary). Leaving the Run/Hold open or high will cause the system to free run at about 3 measurements per second.

TIMING DIAGRAM

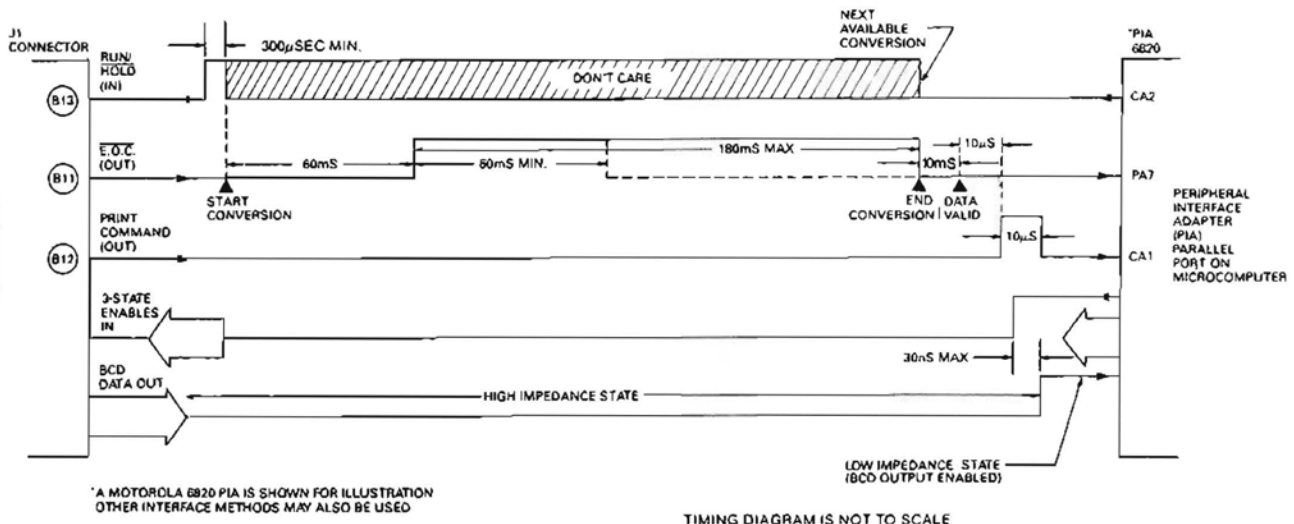

*A MOTOROLA 6820 PIA IS SHOWN FOR ILLUSTRATION
OTHER INTERFACE METHODS MAY ALSO BE USED

TIMING DIAGRAM IS NOT TO SCALE

This applications information shows typical suggested circuits to illustrate design examples. Since Datal-Intersil has no control over the selection, mounting, interconnection, fabrication and environmental factors of external apparatus and components to this product, specific performance cannot be warranted. This information is believed to be accurate and reliable. No responsibility is assumed for any errors or omissions. Nor does Datal-Intersil, Inc. assume responsibility for the use of such information or for any infringement of present or future patents or other third party rights resulting from such use. No license is granted by implication or otherwise under any patent, patent rights, or otherwise of Datal-Intersil, Inc. Prices and specifications are subject to change without notice.

APPLICATIONS

INTRODUCTION

The DM-4101D may be used to interface with a variety of micro-computers, thermal printers, data loggers and so on. The discussion below of DM-4101D BUS INTERFACING provides the general information necessary to any application in which the BCD data from the DM-4101D will be used. Reference should also be made to the BUS INTERFACE BLOCK DIAGRAM on page 8.

A specific interface is also given, as an example: the Motorola 6800/6502 P.I.A. INTERFACE. The diagram and notes describe interconnection of the meter with this particular Motorola microcomputer.

Similar connections with other microcomputers are possible, but are beyond the scope of this data sheet.

BUS INTERFACE

In order to fully implement a typical interface between the DM-4101D and a microcomputer, three functions must be considered. The first function is to start A/D conversion in the DPM. The second function is to recognize that the DPM is ready to transfer valid output data. The third function is to transfer this data.

The microcomputer has two common methods to output start signals to the DPM and two methods to input End of Conversion (Data Valid) signals into the computer. The DPM's start signal can be supplied from a parallel port output on the computer. This port output line is latched and separated from the other busses of the computer and has TTL drive. If the port method is not desired, the start input may be derived from the address decoder technique to be used later in the data transfer section.

The two methods to input the EOC signal from the DPM are the parallel port and an interrupt input line to the computer. The port method is straightforward in that the user's operating program for the computer periodically scans ("polls") an input bit on the computer's parallel port which is connected to the DPM's EOC output. When the EOC port bit goes low (true), and the polling routine discovers this, the program jumps to a routine which transfers the DPM's BCD data. The only problem with the polling routine method is that excessive computer time (and lost efficiency) might be dedicated to sampling the port bit. If sampling is done less often, valid BCD data could sit ready for an excessive time, thereby lowering the total data acquisition throughput, if that is important (it may not be important in many applications with slowly-varying data).

The interrupt method is more efficient if throughput is at a premium. Interrupt involves a separate line or lines to the CPU which get immediate attention when the interrupt is set. There are two types of interrupts found on microcomputers. The less common type found on some controller-type microprocessors requires only a momentary pulse to set the interrupt. This interrupt type is ideal for a pulse version of the EOC Output called the Data Ready Output (pin 812) which is supplied on the DM-4101D.

The more conventional interrupt input requires a handshake procedure as follows: The interrupt input is set and the CPU detects it as fast as possible, given the preselected priority which you, the programmer have written into the software. The CPU responds with an Interrupt Acknowledge (INTA) Output which is intended to clear the original interrupt and avoid retriggering that same interrupt until its function is performed. Since INTA must clear the interrupt, an additional external flip flop is required or other method since the DPM's EOC Output cannot be externally reset. Some external interface circuitry may be needed in any event, so the flip flop will be easy to add.

Once the EOC is detected, either through the polled port or interrupt, it is time to take the data. If the user has persisted with a parallel port so far it may be tempting to tie all 20-odd bits to the rest of the parallel port, assuming a Peripheral Interface device or Peripheral Interface Adapter (Intel 8255 or Motorola 6820) are used. This simplifies matters but sacrifices the great advantage of the 3-state BCD data outputs which is that one data bus can share several DM-4101D's, depending on distance, loading, etc.

A more elegant method is to wire up the DM-4101D's data outputs in three parallel groups of eight bits (assuming an 8-bit microcomputer). Thus, two decades (8 bits) of BCD data may be strobed onto the bus simultaneously by wiring their 2 Enable Inputs together and by toggling these paired Enables in 1-2-3 sequence to strobe out each 2-digit byte. Using this method, three 8-bit bytes completely transfer 4½ decimal digits plus signs and flags.

The Enable inputs are supplied by the computer's CPU and are derived from the memory bus. The Enables may be treated either as I/O Addresses or as Memory Read locations (so called memory-mapped architecture). In either case, the CPU sends an address down the memory bus. An external address decoder is used to create a single pulse input to each Enable input pair by first ANDing the decoder output with either the I/O Read Command output or Memory Read Command Output from the CPU. While this pulse input enables the BCD data gates, the CPU's data bus reads these BCD data bits and routes them to the accumulator. From there they are routed to memory for further processing according to the user's program. If this decoder method is used, it will be noted that the program instruction which moves BCD data from the DPM to the CPU is an I/O Read command: IN N, in 8080 assembly language, for example. It will use the I/O Read Command Output line (IORC) from the computer. The complementary instruction, OUT N may be used with the identical address to start A/D conversion in the DPM, as discussed earlier. If start is used this way, the I/O Write Command (IOWC) Output will be ANDed with the decoder's output to create a start pulse.

With the appropriate address decoder circuit, successive IN N instructions will be physically routed to ascending sets of paired Enable inputs. For example, (in 8080 language)

```
IN N+0
STA M+0
IN N+1
STA M+1
IN N+2
STA M+2
```

will completely strobe out 4½ digits, signs and flags into three successive memory locations. Since the next data sample will write over the previous data, M+0, M+1 and M+2 should be thought of as temporary scratchpad intersample storage and full data manipulation should occur between samples.

BUS INTERFACE BLOCK DIAGRAM

APPLICATIONS (Cont'd)

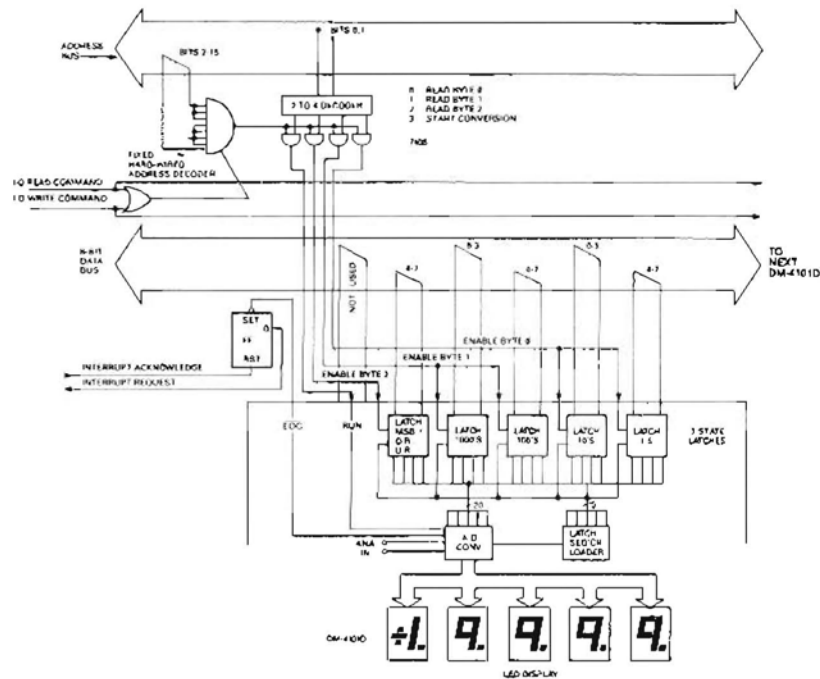

MOTOROLA 6800/6502 P.I.A. INTERFACE

The diagram below indicates wiring between the DM-4101D and a Motorola Peripheral Interface Adapter. Please note that an external 74LS138 decoder is specified:

this permits both 3-state control lines, and BCD data lines, to interface on a single port of the P.I.A. If preferred, the P.I.A.'s B port may be used, and the decoder omitted.

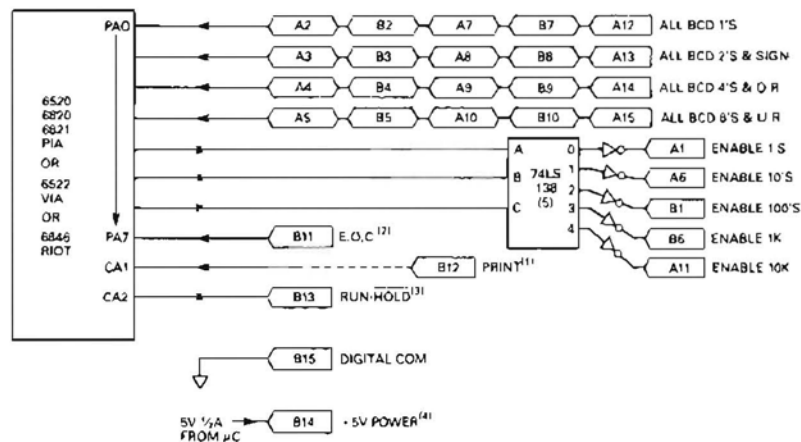

Notes

- 1) For interrupt at end of conversion, connect B12 to CA1 & program PIA to negative or positive edge.
- 2) Due to auto-zero, $\overline{E.O.C.}$ will go high approx. 60mS after initiation of conversion of RUN/HOLD. $\overline{E.O.C.}$ will remain high for a minimum of 60mS for zero analog input, to 180mS for \pm full scale. If polling of the $\overline{E.O.C.}$ is used as check on valid data, the polling sequence should not commence until 100mS after initiation of conversion.
- 3) To initiate a conversion RUN/HOLD should be pulsed high for a minimum of 300 μ S. Additional RUN/HOLD pulses after initiation of conversion until $\overline{E.O.C.}$ goes low will have no effect. If RUN/HOLD is held high continuously, DM-4100D will perform conversions continuously at about 3 conversions/sec.
- 4) 5V @ 1/2 A may be derived from the μ C buss if power supplies have capacity.

