

Low Cost MMIC Mixer with Local Oscillator Amplifier 0.8 - 1.0 GHz

Rev. V1

Features

- -5 to +5 dBm LO Drive Level
- High Isolation, 28 dB LO to RF
- Lead Free SOT-26 package
- 100% Matte Tin Plating over Copper
- Halogen-Free “Green” Mold Compound
- 260°C Re-flow Compatible
- RoHS Compliant Version of MD57-0001

Description

The MAMX-008611 is a floating FET mixer with an on-chip LO amplifier. The LO drive for the MAMX-008611 can range from -5 to +5 dBm without severely impacting the mixer’s performance. The MAMX-008611 is ideally suited for cellular band communications handsets’ that can provide only minimal amounts of LO drive. Typical applications include frequency up/down conversion and IQ modulation and demodulation in digital receivers and transmitters.

The MAMX-008611 utilizes a patented “floating-FET” architecture. The on-chip LO amplifier allows the MAMX-008611 to operate with as little as -5 dBm of LO drive making it an ideal choice for low power portable designs.

The MAMX-008611 is fabricated using M/A-COM’s 0.5 micron low noise GaAs MESFET process. This process features full passivation for increased performance and reliability. The MAMX-008611 is 100% RF tested to ensure superior performance specification compliance.

Ordering Information¹

Part Number	Package
MAMX-008611-000000	SOT-26
MAMX-008611-TR1000	1000 piece reel
MAMX-008611-TR3000	3000 piece reel

1. Reference Application Note M513 for reel size information.

Functional Schematic

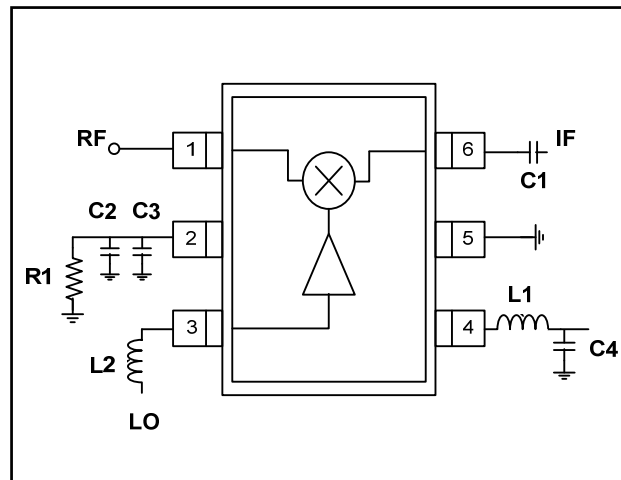

Pin Configuration

Pin No.	Pin Name	Description
1	RF Port	RF Input/Output
2	Bias	LO Amplifier Bias Resistor
3	LO Port	LO Input
4	V _{DD}	LO Amplifier V _{DD}
5	GND	Ground
6	IF Port	IF Input/Output

Absolute Maximum Ratings^{2,3,4,5}

Parameter	Absolute Maximum
Input RF/IF Power ⁴	+27 dBm
Input LO Power ⁴	+17 dBm
Operating Voltages ⁴	V _{DD} = +6 V
Operating Temperature	-30°C to +80°C
Storing Temperature	-65°C to +150°C

2. Exceeding any one or combination of these limits may cause permanent damage to this device.
3. M/A-COM does not recommend sustained operation near these survivability limits.
4. Ambient Temperature (TA) = +25°C
5. Typical Thermal Resistance (θ_{JC}) = 108°C/W at nominal bias

* Restrictions on Hazardous Substances, European Union Directive 2002/95/EC.

Low Cost MMIC Mixer with Local Oscillator Amplifier 0.8 - 1.0 GHz

Rev. V1

Electrical Specifications⁶: $T_A = +25^\circ\text{C}$, RF = 900 MHz (-15 dBm), LO = 730 MHz (-5 dBm), IF = 170 MHz, $V_{DD} = 2.7\text{ V}$, Typical $I_{DD} = 5\text{ mA}$

Parameter	Test Conditions	Units	Min.	Typ.	Max.
Conversion Loss		dB	—	9.3	11
Isolation	LO to RF	dB	20	28	—
	LO to IF	dB	10	12	—
	RF to IF	dB	—	20	—
VSWR	RF Port	Ratio	—	2.0:1	—
	LO Port	Ratio	—	2.0:1	—
	IF Port	Ratio	—	2.0:1	—
Input 1 dB Compression	RF Freq = 900 MHz, LO = -5 dBm	dBm	—	14	—
Two Tone IM Ratio	Two tones @ -10 dBm each; Two spacing = 1 MHz, IF = 170 MHz	dBc	—	59	—

6. IMR vs. RF drive can be calculated by the formula: $\text{IMR} = [44 - 1.5(\text{PIN})]$

Recommended PCB Configuration

Layout View

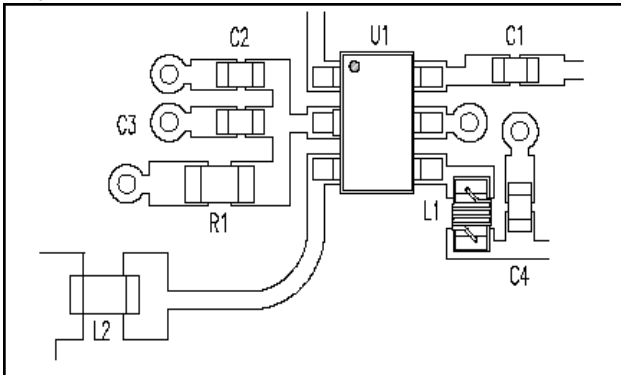

PCB Cross Section View

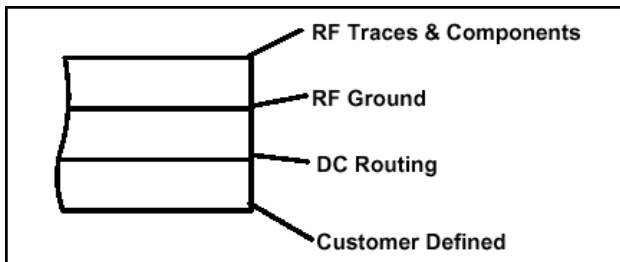

PCB dielectric between RF traces and RF ground layers should be chosen to reduce RF discontinuities between $50\ \Omega$ lines and package pins. M/A-COM recommends an FR-4 dielectric thickness of 0.008" (0.2 mm) yielding a $50\ \Omega$ line width of 0.015" (0.38 mm). The recommended metallization thickness is 1 oz. Copper.

External Circuitry Parts List

Part	Value	Purpose
R1	200 Ω	LO Amplifier Bias Resistor
L1	22 nH	LO Amplifier Bias Input
L2	10 nH	LO Port Matching
C1	10 nF	IF Port Matching
C2	10 nF	IF Bypass Capacitor
C3	22 pF	RF Bypass Capacitor
C4	47 pF	V_{DD} Bypass

Lead-Free SOT-26 Plastic Package[†]

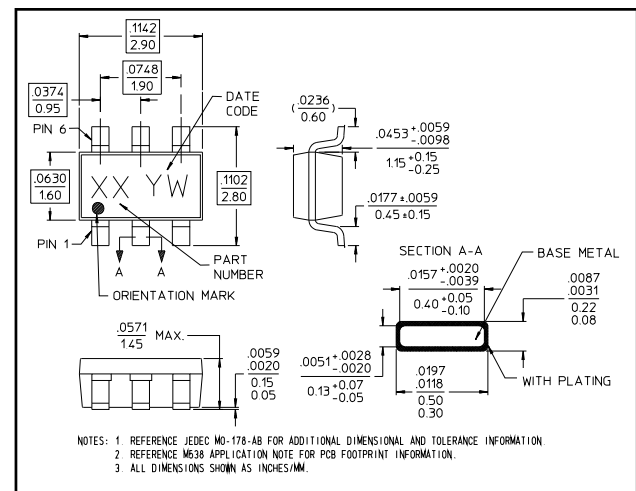

[†] Reference Application Note M538 for lead-free solder reflow recommendations. Meets JEDEC moisture sensitivity level 1 requirements.

Low Cost MMIC Mixer with Local Oscillator Amplifier 0.8 - 1.0 GHz

Rev. V1

Spurious Table

LO Harmonic (n)		RF Harmonic (m)				
		0X	1X	2X	3X	4X
0X	-10 dBm	X	4.1	44.9	69.5	79.7
	0 dBm	X	3.9	31.9	48.4	70.0
1X	-10 dBm	13.8	0	47.6	82.0	76.6
	0 dBm	22.9	0	35.1	73.0	83.8
2X	-10 dBm	10.8	18.9	46.5	70.6	78.0
	0 dBm	20.4	18.9	36.6	55.9	84.0
3X	-10 dBm	12.1	23.8	41.5	76.9	77.1
	0 dBm	22.7	23.8	31.0	63.1	74.0
4X	-10 dBm	13.6	50.9	68.5	64.5	80.6
	0 dBm	24.0	49.4	58.9	45.4	63.4

- The spurious table shows the spurious signals resulting from the mixing of the RF and LO input signals assuming down conversion.
- Mixing products are indicated relative to the IF level.
- The lower frequency mixing term is shown for two different RF input levels.
- The RF frequency is 900 MHz, the LO frequency is 730 MHz.

[$n_{FRF} - m_{FLO}$] RF = -10 dBm
 [$n_{FRF} - m_{FLO}$] RF = 0 dBm

Typical Performance Data

Down Converter Application Test Conditions:

RF=900 MHz, IF=170 MHz, LO=730 MHz (LO Power = -5dBm)

Conversion Loss vs. Frequency

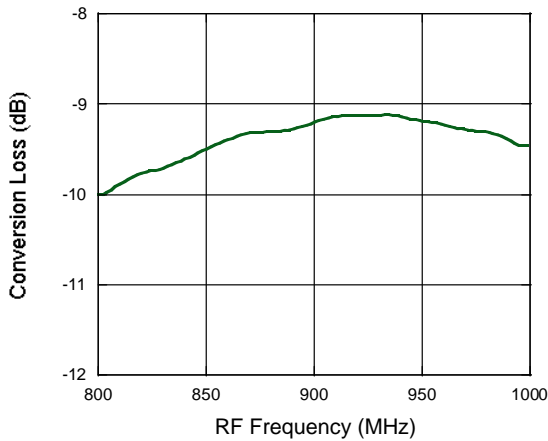

VSWR vs. Frequency

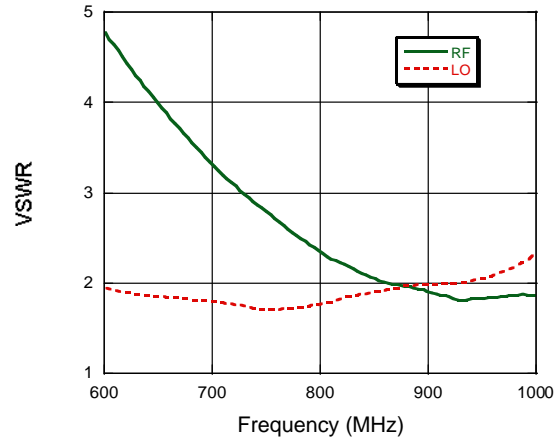

IMR Plot

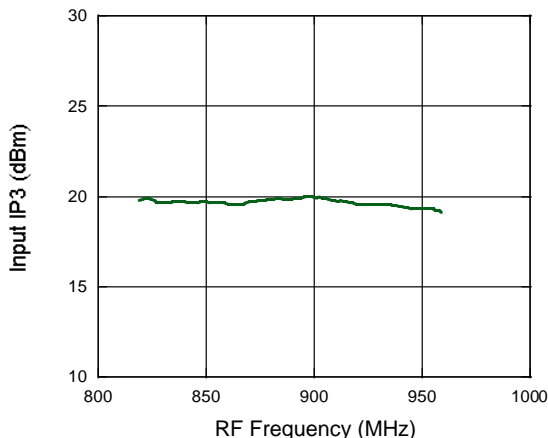

Isolations

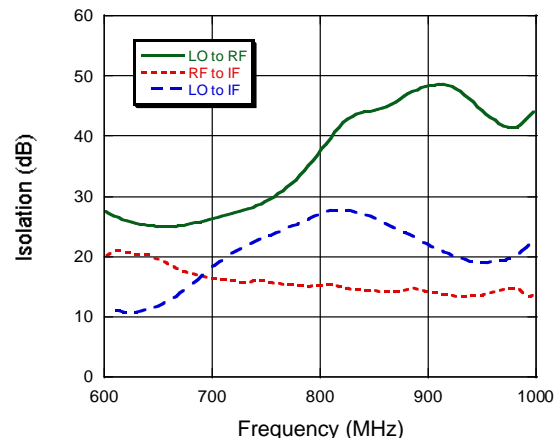

ADVANCED: Data Sheets contain information regarding a product M/A-COM Technology Solutions is considering for development. Performance is based on target specifications, simulated results, and/or prototype measurements. Commitment to develop is not guaranteed.
PRELIMINARY: Data Sheets contain information regarding a product M/A-COM Technology Solutions has under development. Performance is based on engineering tests. Specifications are typical. Mechanical outline has been fixed. Engineering samples and/or test data may be available. Commitment to produce in volume is not guaranteed.

• **North America** Tel: 800.366.2266 / Fax: 978.366.2266
 • **Europe** Tel: 44.1908.574.200 / Fax: 44.1908.574.300
 • **Asia/Pacific** Tel: 81.44.844.8296 / Fax: 81.44.844.8298
 Visit www.macontech.com for additional data sheets and product information.

M/A-COM Technology Solutions Inc. and its affiliates reserve the right to make changes to the product(s) or information contained herein without notice.