

### Switch Fabric Solution with Carrier Class QoS Features for Applications up to 320 Gbps

The AMCC PRS Q-80G is a switch device for systems up to 320 Gbps of aggregate user bandwidth. The PRS Q-80G is a cell switch, shared-memory device, which provides 80 Gbps of switching capacity. It uses .13-micron technology and embedded 3.2-Gbps SerDes to deliver 40 Gbps of user bandwidth with an overspeed factor of two.

Along with the AMCC PRS C48X and PRS C192X fabric interface devices, the PRS 80G addresses the critical QoS needs of a wide range of highly demanding applications that handle any mix of real-time and best effort traffic in the WAN multi-services, Wireless Infrastructure, Metro Ethernet, Enterprise, and TDM spaces. The PRS Q-80G provides low latency, carrier class QoS and full bandwidth multicast to efficiently handle real-time traffic (including TDM) and enable convergence of voice, video, and data traffic over a single network infrastructure. It fits the requirements of the new carrier services, while leveraging previous carrier investments by providing the capability to switch IP and TDM traffic concurrently on the same platform.

The PRS Q-80G is an integral part of a complete system solution with AMCC's nP37xx integrated network processor and traffic manager products, framers, PHYs, PowerPC processors, and software. To facilitate the evaluation and prototyping of complete solutions, AMCC also offers 80-Gbps and 320-Gbps reference switch boards.

### PRS Q-80G Switch Device, PRS C48X and PRS C192X Fabric Interface Devices

The PRS Q-80G device performs the switch core function, in configurations of two, four, or eight devices, depending on the switching capacity needs. The PRS C48X and PRS C192X devices perform the queuing manager function of the PRS Q-80G-based switches. An adapter card can be equipped with either a PRS C48X interfacing a 2.5-Gbps / OC-48 network processor or a PRS C192X interfacing a 10-Gbps / OC-192 network processor or up to four 2.5-Gbps / OC-48 network processors.

### Scalability and Multiple Port Speeds

The PRS Q-80G switch, in conjunction with the PRS C48X and PRS C192X fabric interface devices, provides 80 Gbps (two devices), 160 Gbps (four devices), or 320 Gbps (eight devices) of full-duplex aggregate user bandwidth with an overspeed factor per-port of two to match wire-speed requirements for all possible traffic patterns, with all line protocols.

The PRS Q-80G enables the design of single-stage switch fabrics with up to 32 ports for network processors that support OC-192c, 10-Gbps, and multi-GE applications, or up to 128 ports for network processors that support OC-48c and multi-GE applications, or any intermediate mix of those ports.

The PRS Q-80G also has built-in a 40-Gbps clear channel attachment capability, requiring a customer ASIC or FPGA to interface with a 40-Gbps protocol engine.

### RoHS Compliance to Enable Lead Free Designs

The PRS C48X and PRS C192X fabric interface devices are available in two versions: the leaded version, for lead soldering process, and the version complying with the directive on the Restriction of the use of certain Hazardous Substances (RoHS) and enabling lead free soldering.

### QoS Enforcement at Media Speed

The PRS Q-80G enables full bandwidth utilization of the media connected to the payload boards, and still maintains high QoS performance:

- End-to-end flow control mechanisms through the switch fabric, and programmable flow control thresholds (including multicast), enabling 100% utilization of the media bandwidth while maintaining low jitter
- Natively multicast switching technology, enabling full bandwidth multicast while maintaining low switching delay

## - Highlights -

### QoS Enforcement at Media Speed, Real-Time Traffic Support, Full Bandwidth Multicast

- Non-blocking, shared-memory, single-stage switch fabric chip set: PRS Q-80G cell switch device providing 80 Gbps of aggregate switching capacity, PRS C48X and PRS C192X fabric interface devices (queue managers)
- PRS C48X and PRS C192X available in RoHS compliant version for lead free designs
- Up to 320 Gbps (eight devices) of full-duplex aggregate user bandwidth with a per-port overspeed factor of 2
- QoS enforcement at media speed
- Real-time traffic support (guaranteed precedence of time-sensitive traffic over other traffic types)
- Multicast and broadcast full bandwidth support (100% line utilization) while preserving low switching delay
- Deterministic low latency, typically a few microseconds for high priority traffic under worst case conditions (100% traffic load)
- Traffic scheduling QoS options: strict priority scheduling, weighted round-robin, exhaustive highest priority first
- End-to-end, in-band flow control mechanisms through the switch fabric
- Redundant switch board operations: hot standby mode, load sharing mode, maintenance switchover (cell lossless)
- AMCC SSC software for configuration, monitoring, and control of the switch board and AMCC SWICC software, a PC tool for local/remote testing (traffic generation, digital eye, and so on)
- Evaluation switch boards, featuring two PRS Q-80G (80 Gbps) or eight PRS Q-80G (320 Gbps)
- System solution with AMCC's nP37xx, framers, PHYs, and PowerPC processors, and interoperability with third-party network processor devices

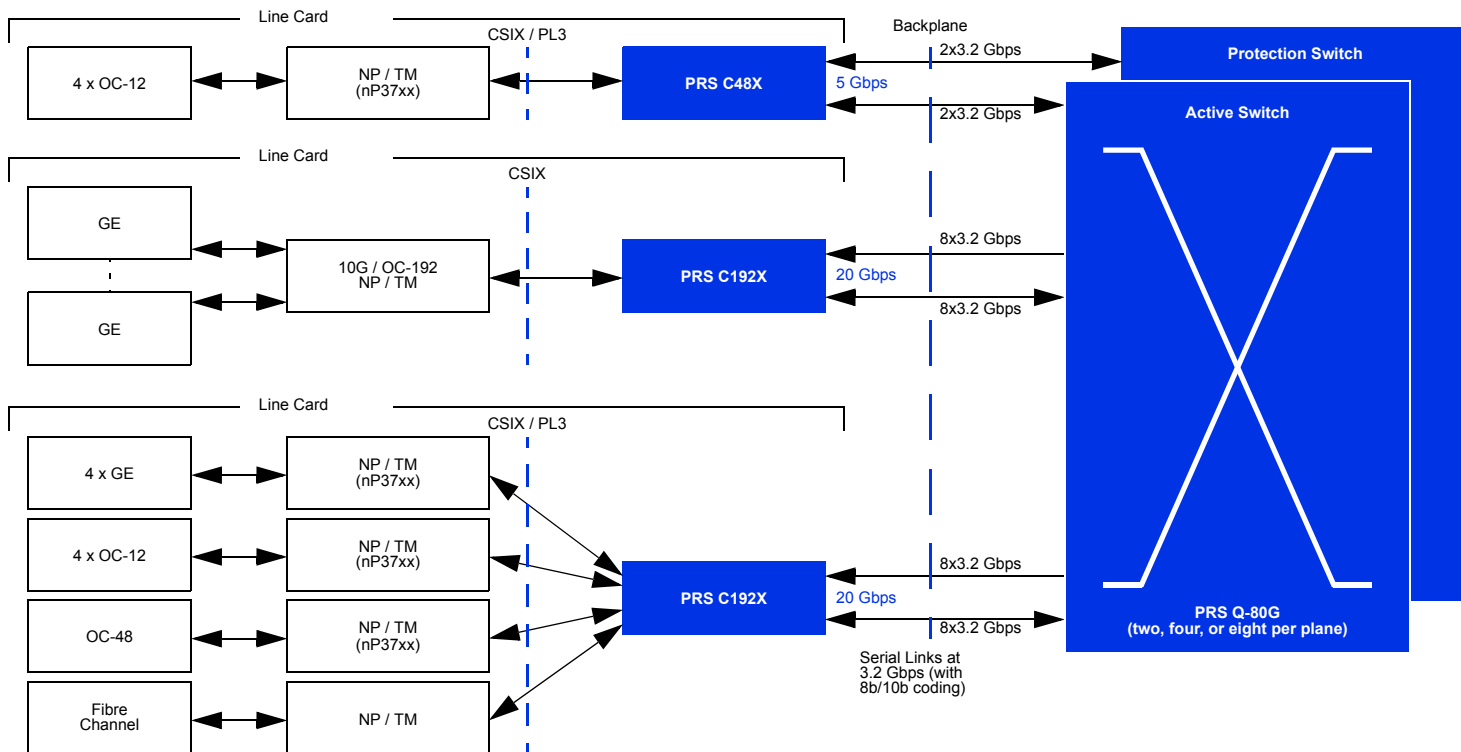

PRS Q-80G Switch with PRS C48X and PRS C192X Fabric Interfaces

### Support of Real-Time Traffic (TDM)

The PRS Q-80G addresses the technical challenges (latency, jitter) of merging real-time traffic with other traffic types over a single communication infrastructure:

- Deterministic low latency, typically a few microseconds transit delay in worst case conditions (100% traffic load) for high priority traffic.
- Guaranteed precedence of time-sensitive traffic (for example, TDM) over other traffic types, using fully preemptive traffic priority.

### Full Bandwidth Multicast

The PRS Q-80G addresses the growing needs of audio and video distribution applications, thanks to its powerful multicast and broadcast mechanisms: cell replication at sending, with cells being scheduled at different times for different output ports.

### Multiple QoS Options

The PRS Q-80G can be suited to the application specific QoS requirements thanks to multiple traffic scheduling options:

- Strict traffic priority scheduling
- Configurable credit table (weighted round-robin) to guarantee bandwidth to lower priority traffic

- Credit Table with fully preemptive highest traffic priority (exhaustive scheduling)

### Switch Board Redundancy for High Availability

The PRS Q-80G can be designed to operate in redundant switch board configurations that address the high-availability requirements of five-nine applications. On the payload boards, the PRS C48X and PRS C192X Fabric Interface chips provide a redundant path with the switch boards.

The PRS Q-80G supports three redundancy modes: hot standby mode (with automatic takeover of the traffic of the failing active board), traffic load sharing between the two switch boards (with automatic take over of the traffic of the failing board), and maintenance switchover between switch boards (without any service interruption and no cell loss).

### Control Software

The control processor of the switch board runs the AMCC Secondary Switch Controller software (SSC), in charge of configuring, monitoring, and controlling the switch board operations. The SSC initializes the cell switch device, performs diagnostics, monitors device status, accumulates statistics, and in

a redundant switch configuration, communicates with its peer to perform system recovery in case of component failure.

In addition, the AMCC Switch Integrated Control Console (SWICC) tool, a PC software application, enables access to any addressable resources in the switch device to initiate or monitor any operational or test function (for example, traffic generation, digital eye, sense and operate of any bit, loop back, and so on). The SWICC can be used locally, on the customer premises, or for remote support.

### Backward Compatibility

The PRS Q-80G, PRS C48X, and PRS C192X chipset offers backward compatibility enabling co-population of both existing and new line cards in the same chassis: the PRS Q-80G switch chip SerDes can operate at 2.5 Gbps per serial link (instead of 3.2 Gbps) to support line cards based on the previous PRS C192 fabric interface chip, while the PRS C48X and PRS C192X interface chips SerDes can operate at 2.5 Gbps per serial link (instead of 3.2 Gbps) to operate with switch cards based on the previous PRS 64Gu or PRS Q-64G switch chips.

### AMCC Software, Evaluation Platforms, Reference Designs, Development Tools, and Design Support for Time-to-Market

To help Telecom Equipment Manufacturers to evaluate and prototype complete solutions, shorten project cycles, mitigate development risks, and optimize their development costs, PRS Q-80G evaluation platforms, validated with evaluation boards from major NP/TM vendors, are available from AMCC. They include an 80-Gbps switch board (two devices) and a 320-Gbps switch board (eight devices) that can be operated also in a 160-Gbps configuration.

Switch core reference designs incorporating the AMCC PowerPC 405EP control processor, software to operate the switch boards, PC-based tool to initiate or monitor any operational or test function (for example, traffic generation, digital eye, sense and operate of any bit, loop back, and so on), board design services, and board manufacturing capabilities complement the AMCC PRS offering.

### PRS Q-80G Switch Core Device Features

The PRS Q-80G switch core device offers the following features:

- Non-blocking, single-stage, shared-memory switch
- Device aggregate throughput: 80 Gbps
- One-device switch: 40 Gbps of aggregate user bandwidth (16x16 ports at 2.5-Gbps/OC-48c speed, or 4x4 ports at 10-Gbps/OC-192c speed)
- Two-device switch: 80 Gbps of aggregate user bandwidth (32x32 ports at 2.5-Gbps/OC-48c speed, or 8x8 ports at 10-Gbps/OC-192c speed)
- 2.5-Gbps ports with speed-up factor of two (in conjunction with PRS C48X fabric interface)
- 10-Gbps ports with speed-up factor of two (in conjunction with PRS C192X fabric interface)
- 10-Gbps port operation in 4x 2.5-Gbps mode (in conjunction with PRS C192X fabric interface)
- Embedded SerDes: 3.2-Gbps high-speed serial links, XAUI compliant, with 8b/10b encoding for link synchronization and supervision
- Multicast and broadcast without cell duplication in shared memory (cell replication at sending)
- TDM traffic support
- Traffic priorities (CoS): up to four (configurable number)
- Output queue scheduling options: strict priority scheduling, configurable credit table (weighted round-robin), exhaustive highest priority first
- Redundant switch plane operations: hot standby or load sharing mode, programmable scheduled switchover (cell lossless)
- Flow control based on a grant mechanism, subport flow control
- Programmable flow control thresholds for output queues, shared memory, multicast/broadcast
- Fixed-length cells with configurable length (64, 72, or 80 bytes)
- Programmable cell header size: two, three, or five bytes, independent of the switch configuration, containing destination bitmap, packet priority, and switch redundancy support information, all protected by a parity bit

- Local control processor interface (serial host interface)
- Reception (transmission) of control cells sent to (by) the local processor on any input (output) port
- AMCC software for switch board control, PC-based development / test tools
- Pin-to-pin and switch control software compatibility with PRS 64Gu switch core
- Backward compatibility with PRS C48 or PRS C192 fabric interfaces: SerDes operation at 2.5 Gbps (speed-up factor of 1.6)

Inter-operability in PRS Q-80G chassis: line cards with any of the PRS C48, PRS C48X, PRS C192, and PRS C192X devices

### PRS C48X and PRS C192X Fabric Interface Device Features

- Port queuing manager (one per line card) between one or multiple network processors and a PRS 80G or PRS Q-80G switch core
- PRS 80G or PRS Q-80G interface: embedded 3.2-Gbps SerDes, with 8b/10b coding, and a speed-up factor of two, or eight between the PRS Q-80G and PRS C48X
- PRS C48X: CSIX-L1 or PL3-based (POS-PHY Level 3 / OIF-SPI3-01.0) 32-bit wide interface for 2.5-Gbps / OC-48 network processor
- PRS C192X: CSIX-L1 64-bit wide or 128-bit wide interface for 10-Gbps / OC-192 network processor or, in subport mode, 4x CSIX-L1 or PL3-based (POS-PHY Level 3 / OIF-SPI3-01.0) 32-bit wide interfaces for 2.5-Gbps / OC-48 network processors
- PRS C192X operation in subport (or quad PRS C48X) mode with PRS 64Gu, PRS 80G, PRS Q-64G, and PRS Q-80G switch cores
- Dual-switch attachment for redundant switch plane operations
- Ingress virtual output queuing (VOQ), with up to 1024 unicast queues and eight (PRS C48X) or 32 (PRS C192X) multicast queues, preventing head-of-line blocking
- Up to four levels of traffic priority (CoS) and four programmable ingress queue thresholds (ingress CSIX / PL3 flow control per destination and priority)
- Shared ingress buffer and egress buffer capacities (configurable), with sharing capability between planes
- Switch interface ingress cell scheduling: strict priority scheduling, credit table (weighted round-robin), exhaustive highest priority first
- End-to-end cell payload protection, with optional cyclic redundancy check insertion
- Internal loopback support for both the CSIX / PL3 interface and switch interface
- Backward compatibility with PRS 64Gu switch core: SerDes operation at 2.5 Gbps, with speed-up factor of 1.6
- Backward compatibility with PRS Q-64G switch core: SerDes operation at 2.5 Gbps, with speed-up factor of 1.6 (PRS C192X) or 6.4 (PRS C48X)
- Inter-operability in PRS 64Gu and PRS Q-64G chassis: line cards with any of the PRS C48 (PRS 64Gu chassis only), PRS C48X, PRS C192, and PRS C192X devices

## Specifications

	PRS Q-80G	PRS C48X	PRS C192X
Technology	0.13 $\mu\text{m}$	0.13 $\mu\text{m}$	0.13 $\mu\text{m}$
Supply voltage	1.5 V, 2.5 V	1.5 V, 2.5 V	1.5 V, 2.5 V
Typical power @100% traffic load	14.2 Watts (master) 16.9 Watts (slave) 14.7 Watts (last slave)	4.3 Watts	9 Watts
Junction °C	0°C to 125°C	0°C to 125°C	0°C to 125°C
Package	624-ball CBGA	899-ball FC-PBGA	937-ball CBGA
mm x mm (pitch)	32.5x32.5 (1.27 mm)	31x31 (1 mm)	32.5 x 32.5 (1 mm)

AMCC reserves the right to make changes to its products, or to discontinue any product or service without notice, and advises its customers to obtain the latest version of relevant information to verify, before placing orders, that the information being relied upon is current.

AMCC is a registered trademark of Applied Micro Circuits Corporation. Copyright © 2006 Applied Micro Circuits Corporation. All Rights Reserved.

Other company, product, and service names may be trademarks or service marks of others.

6290 Sequence Drive • San Diego, CA 92121 • Tel: 858 450-9333 • Fax: 858 450-9885 • <http://www.amcc.com>

For technical support, please call 800 840-6055 or email [productsupport@amcc.com](mailto:productsupport@amcc.com)