

POWER RELAY

1 POLE—1, 3, 5, 10 A (CADMIUM FREE CONTACTS TYPE)

LZG SERIES

■ FEATURES

- UL (UL372, UL508, UL873), CSA, VDE
- 4 kinds of contact ratings
 - Low level to 10 amps switching
- Standard and high sensitivity types available
- High isolation in small package
 - Dielectric strength: 2,500 VAC (between coil and contacts)
 - Surge strength: 7,000 V
- UL class B (130°C) insulation type available (only plastic sealed type)
- Plastic sealed type
- Printed circuit terminals compatible with LZ relay
- Environmentally friendly cadmium free contact type is available.



■ ORDERING INFORMATION

[Example] LZG - B 12 H M S E - K
(a) (b) (c) (d) (e) (f) (g) (h)

(a)	Series Name	LZG: LZG Series
(b)	Coil Heat Proof Class	Nil : Standard type B : UL Class B insulation type (130°C)
(c)	Nominal Voltage	Refer to the COIL DATA CHART
(d)	Contact Rating	Nil : 3 A H : 5 A V : 10 A (only LZG-M) W : 1 A (bifurcated)
(e)	Contact Arrangement	Nil : 1 form C (SPDT) M : 1 form A (SPST-NO)
(f)	Coil Type	Nil : Standard type S : High sensitivity type (without LZG-V)
(g)	Contact Material (Rating)	Nil : Gold overlay silver-palladium (only LZG-W) Nil : Gold overlay silver-nickel (3 A, 5 A) Nil : Silver alloy (10 A) (only LZG-VM) E : Silver-nickel (3 A, 5 A)
(h)	Enclosure	Nil : Flux free type K : Plastic sealed type (only LZG-B) C : Plastic sealed type (with tape) (only LZG-B)

■ SAFETY STANDARD AND FILE NUMBERS

UL372, 508, 873 (File No. E56140)

C 22.2 No. 14 (File No. LR35579)

VDE 0435 (File No. 11039-4940-1004)

Please note that UL/CSA/VDE ratings may differ from the standard ratings. Only "NIL" and "H" contacts have VDE approval.

Please request when the approval markings are required on the cover and/or relay recognized by SEV is required.

Type	Nominal voltage	Contact rating
LZG- () LZG- ()S	1.5 to 48 VDC 1.5 to 24 VDC	1/10 HP 120 VAC/240 VAC 2.5 A 240 VAC resistive 3 A 30 VDC/120 VAC resistive Pilot duty D 150
LZG- ()H LZG- ()HS	1.5 to 48 VDC 1.5 to 24 VDC	1/8 HP 120 VAC/240 VAC 4 A 240 VAC resistive 5 A 30 VDC/120 VAC resistive 1 A 250VAC inductive Pilot duty C 150
LZG- ()VM	1.5 to 48 VDC	1/4 HP 120 VAC/240 VAC 7 A 240 VAC resistive 10 A 24 VDC/120 VAC resistive Pilot duty C 150

DISCONTINUED

LZG SERIES

■ SPECIFICATIONS

Item		10 A Type	5 A Type	3 A Type	1 A Type
		LZG-()VM	LZG-()H, LZG-()HE	LZG(), LZG-()E	LZG-()W
Contact	Arrangement	1 form A (SPST-NO)	1 form A (SPST-NO) or 1 form C (SPDT)		
	Material	Silver alloy	Gold overlay silver alloy		Gold overlay silver-palladium
	Style	Single			Bifurcated
	Resistance (initial) (at 1 A 6 VDC)	Maximum 70 mΩ (LZG-H) Maximum 100 mΩ (LZG-VM, HE, E)			Max. 50 mΩ
	Rating (resistive)	10 A 120 VAC/24 VDC 1/4 HP 120 VAC	5 A 120 VAC/24 VDC 1/8 HP 120 VAC	3 A 120 VAC/30 VDC 1/10 HP 120 VAC	1 A 120 VAC/30 VDC
	Maximum Carrying Current	10 A	5 A		1 A
	Maximum Switching Power	1,680 VA, 240 W	960 VA, 120 W	600 VA, 90 W	190 VA, 30 W
	Maximum Switching Voltage	250 VAC, 150 VDC			
	Maximum Switching Current	10 A	5 A	3 A	1 A
	Minimum Switching Load*1	10 mA 5 VDC (LZG-H) 100 mA 5 VDC (LZG-VM, HE, E) 0.1 mA 100 VDC			
Coil	Nominal Power (at 20°C)	Standard type: 0.45 to 0.6 W High sensitivity type: 0.33 W			
	Operate Power (at 20°C)	Standard type: 0.17 to 0.22 W High sensitivity type: 0.14 W			
	Operating Temperature	Standard type: -30°C to +70°C (no frost) High sensitivity type: -30°C to +80°C (no frost) (refer to the CHARACTERISTIC DATA)			
Time Value	Operate (at nominal voltage)	Maximum 7 ms			
	Release (at nominal voltage)	Maximum 4 ms			
Insulation	Resistance (at 500 VDC)	Minimum 250 MΩ			
	Dielectric Strength	between open contacts	750 VAC 1 minute		
		between coil and contacts	2,500 VAC 1 minute		
Surge Strength	7,000 V (at 1.2 × 50 μs)				
Life	Mechanical	2 × 10 ⁷ operations minimum			
	Electrical	1 × 10 ⁵ operations minimum (rated load)			
Other	Vibration Resistance	Misoperation	10 to 55 Hz (double amplitude of 3.3 mm)		
		Endurance	10 to 55 Hz (double amplitude of 3.3 mm)		
	Shock Resistance	Misoperation	100 m/s ² (11 ±1 ms)		
		Endurance	1,000 m/s ² (6 ±1 ms)		
Weight	Approximately 9.2 g				

*1 Minimum switching loads mentioned above are reference values. Please perform the confirmation test with the actual load before production since reference values may vary according to switching frequencies, environmental conditions and expected reliability levels.

LZG SERIES

■ COIL DATA CHART

	MODEL				Nominal voltage	Coil resistance (±10%)	Must operate voltage	Must release voltage	Nominal power
	Single			Bifurcated					
	10 A Type	5 A Type	3 A Type	1 A Type					
Standard Type	LZG-(B) 1.5 VM	LZG-(B) 1.5H (M) (E)	LZG-(B) 1.5 (M) (E)	LZG-(B) 1.5 W (M)	1.5 VDC	5 Ω	0.97 VDC	0.08 VDC	450 mW
	LZG-(B) 3 VM	LZG-(B) 3H (M) (E)	LZG-(B) 3 (M) (E)	LZG-(B) 3 W (M)	3 VDC	20 Ω	1.95 VDC	0.15 VDC	450 mW
	LZG-(B) 5 VM	LZG-(B) 5H (M) (E)	LZG-(B) 5 (M) (E)	LZG-(B) 5 W (M)	5 VDC	56 Ω	3.25 VDC	0.25 VDC	450 mW
	LZG-(B) 6 VM	LZG-(B) 6H (M) (E)	LZG-(B) 6 (M) (E)	LZG-(B) 6 W (M)	6 VDC	80 Ω	3.9 VDC	0.3 VDC	450 mW
	LZG-(B) 9 VM	LZG-(B) 9H (M) (E)	LZG-(B) 9 (M) (E)	LZG-(B) 9 W (M)	9 VDC	180 Ω	5.85 VDC	0.45 VDC	450 mW
	LZG-(B) 12 VM	LZG-(B) 12H (M) (E)	LZG-(B) 12 (M) (E)	LZG-(B) 12 W (M)	12 VDC	320 Ω	7.8 VDC	0.6 VDC	450 mW
	LZG-(B) 18 VM	LZG-(B) 18H (M) (E)	LZG-(B) 18 (M) (E)	LZG-(B) 18 W (M)	18 VDC	720 Ω	11.7 VDC	0.9 VDC	450 mW
	LZG-(B) 24 VM	LZG-(B) 24H (M) (E)	LZG-(B) 24 (M) (E)	LZG-(B) 24 W (M)	24 VDC	1,280 Ω	15.6 VDC	1.2 VDC	450 mW
	LZG-(B) 48 VM	LZG-(B) 48H (M) (E)	LZG-(B) 48 (M) (E)	LZG-(B) 48 W (M)	48 VDC	3,800 Ω	28.8 VDC	2.4 VDC	600 mW
High Sensitivity Type	LZG-(B) 1.5H (M)S (E)	LZG-(B) 1.5 (M)S (E)	LZG-(B) 1.5 W (M) S	1.5 VDC	6.8 Ω	0.97 VDC	0.08 VDC	330 mW	
	LZG-(B) 3H (M)S (E)	LZG-(B) 3 (M)S (E)	LZG-(B) 3 W (M) S	3 VDC	27 Ω	1.95 VDC	0.15 VDC	330 mW	
	LZG-(B) 5H (M)S (E)	LZG-(B) 5 (M)S (E)	LZG-(B) 5 W (M) S	5 VDC	80 Ω	3.25 VDC	0.25 VDC	330 mW	
	LZG-(B) 6H (M)S (E)	LZG-(B) 6 (M)S (E)	LZG-(B) 6 W (M) S	6 VDC	110 Ω	3.9 VDC	0.3 VDC	330 mW	
	LZG-(B) 9H (M)S (E)	LZG-(B) 9 (M)S (E)	LZG-(B) 9 W (M) S	9 VDC	250 Ω	5.85 VDC	0.45 VDC	330 mW	
	LZG-(B) 12H (M)S (E)	LZG-(B) 12 (M)S (E)	LZG-(B) 12 W (M) S	12 VDC	440 Ω	7.8 VDC	0.6 VDC	330 mW	
	LZG-(B) 18H (M)S (E)	LZG-(B) 18 (M)S (E)	LZG-(B) 18 W (M) S	18 VDC	990 Ω	11.7 VDC	0.9 VDC	330 mW	
	LZG-(B) 24H (M)S (E)	LZG-(B) 24 (M)S (E)	LZG-(B) 24 W (M) S	24 VDC	1,780 Ω	15.6 VDC	1.2 VDC	330 mW	

Note: All values in the table are measured at 20 °C.

LZG SERIES

CHARACTERISTIC AND REFERENCE DATA

Please see LZ relays.

DIMENSIONS

● Dimensions

LZG-M type

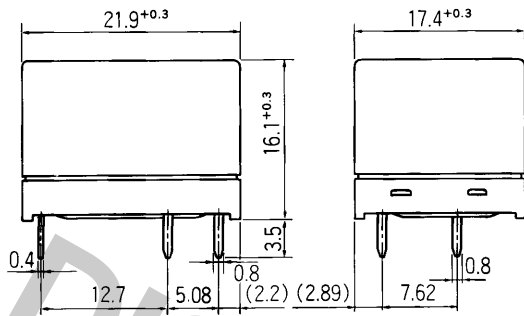

● Schematics

(BOTTOM VIEW)

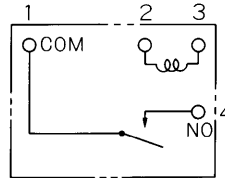

● PC board mounting hole layout

(BOTTOM VIEW)

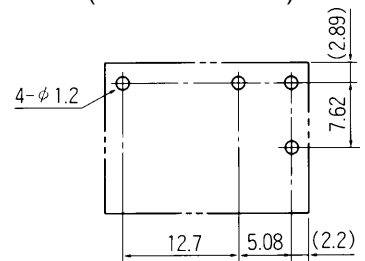

LZG-M-K, LZG-M-C type (Plastic sealed type)

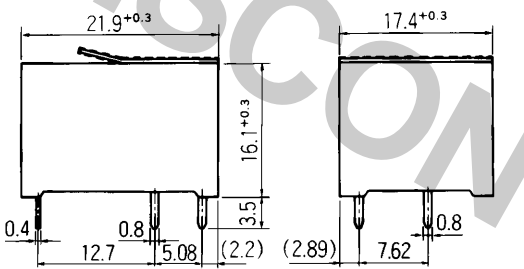

Dotted line : Seal tape (LZG-M-C Type)

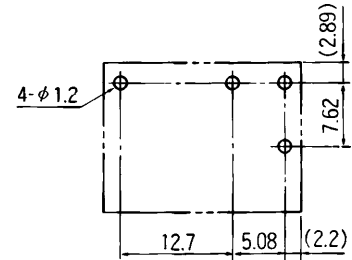
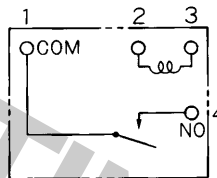

LZG type

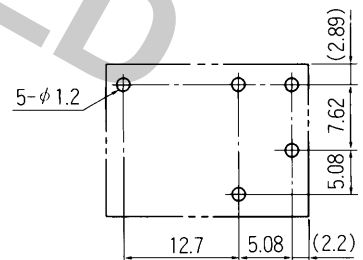
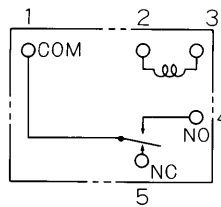
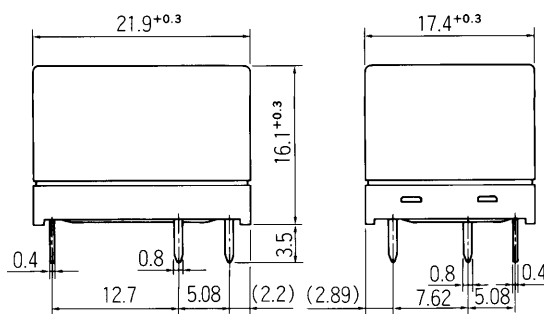

LZG-K, LZG-C type (Plastic sealed type)

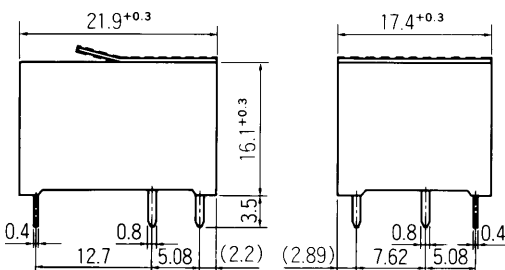

Dotted line : Seal tape (LZG-C type)

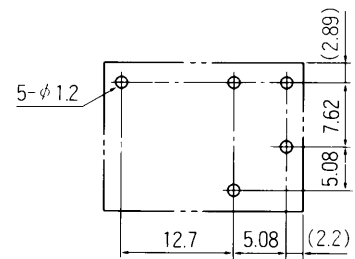
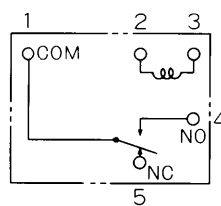

Unit: mm

Fujitsu Components International Headquarter Offices

Japan

Fujitsu Component Limited
Gotanda-Chuo Building
3-5, Higashigotanda 2-chome, Shinagawa-ku
Tokyo 141, Japan
Tel: (81-3) 5449-7010
Fax: (81-3) 5449-2626
Email: promothq@ft.ed.fujitsu.com
Web: www.fcl.fujitsu.com

North and South America

Fujitsu Components America, Inc.
250 E. Caribbean Drive
Sunnyvale, CA 94089 U.S.A.
Tel: (1-408) 745-4900
Fax: (1-408) 745-4970
Email: marcom@fcai.fujitsu.com
Web: www.fcai.fujitsu.com

Europe

Fujitsu Components Europe B.V.
Diamantlaan 25
2132 WV Hoofddorp
Netherlands
Tel: (31-23) 5560910
Fax: (31-23) 5560950
Email: info@fceu.fujitsu.com
Web: www.fceu.fujitsu.com

Asia Pacific

Fujitsu Components Asia Ltd.
102E Pasir Panjang Road
#04-01 Citilink Warehouse Complex
Singapore 118529
Tel: (65) 6375-8560
Fax: (65) 6273-3021
Email: fcal@fcal.fujitsu.com
www.fcal.fujitsu.com

© 2004 Fujitsu Components America, Inc. All company and product names are trademarks or registered trademarks of their respective owners. Rev. 10/27/2004.

DISCONTINUED