



TRAP REMOTE CONTROL SYSTEMS (SW ADDRESSING)

- FM Radio Remote Control
- Upto 600 metres Range
- Simple Switch Addressing to Match Tx and Rx
- 256 Possible Address Combinations
- Robust Enclosures (IP54, IP65) with Industrial Switch
- Easy Installation via Screw Terminals
- Receiver Supply: 12 or 24Vdc
- 4 Relay Outputs
- Ideal for Clay Trap Releases
- Complies with ETSI300-220
- Audio Input / External Switch Option Available



Description

This general purpose radio remote control system is supplied with rugged enclosures designed for a wide range of applications such as Clay pigeon Trap Releases.

The Radio set uses the latest 'Narrow Band' Crystal controlled FM Radio Circuitry operating at 434.075MHz for reliable operation. Supplied ready to operate, the only connections required are to the receiver/decoder. All connections are via screw terminals.

A simple 'Switch link' is used to set the address of the transmitter and the receiver. This is used to enable one or many transmitters to operate one or many receivers.

The transmitter requires a PP3 type battery (Supplied) and is supplied with an Aluminium pocket clip

Standard Products

Part Number	Description
114C1-075FR6	Narrow Band Transmitter Encoder 1 Switch
114C3-075FR6	Narrow Band Transmitter Encoder 3 Switches
117C4-075FR7	Narrow Band Receiver Decoder 4 Relays

Care and Maintenance

The Transmitter enclosure is shower proof (IP54) do not immerse in water!

Applications

Firmly fix the receiver unit approx. 2metres from the ground, ideally in direct sight of the transmitter. Obstacles between transmitter and receiver will reduce range!

Although the system is supplied pre-wired for a specific Clay Trap Release (See below). The remote Control system may be configured for many different applications.

Each switch on the transmitter operates one of the relays on the receiver unit. The Relay output will operate for the duration of the transmitter switch press. Output Relay '1' has a time delay circuit included. This is factory set to approx ½ second momentary delay.

TRAP REMOTE CONTROL SYSTEMS (SW ADDRESSING)

Addressing

Each transmitter and receiver contains an address Switch. This is used to set the identity of the unit. In order for a receiver to respond to a transmitter, the addressees must match,. This enables the user to set individual transmitter and receivers to operate or not operate with each other. It also enables multiple systems to operate within the same vicinity without causing interference.

Each system is supplied ready configured, and does not need to be altered.

However, if you require a different address (e.g. if you have two systems in close proximity or wish to have several receivers to one transmitter etc);

- There are 8 address 'Switches' which the transmitter and receiver use to identify themselves.
- The Receiver and Transmitter units must have the same Address 'Switches' in order to recognise each others signal.

The following table shows the Circuit board address 'Switches' for the transmitter and receiver circuit boards.

Address Number	1	2	3	4	5	6	7	8
Transmitter Address 'SW1'	A1	A2	A3	A4	A5	A6	A7	A8
Receiver Address 'LK1'	1	2	3	4	5	6	7	8

Relay Output Connections

Upto 4 relays are provided on the receiver output. The relay output provides a 'switch' output which operates when the transmitter switch is pressed. Each relay has the connections as below.

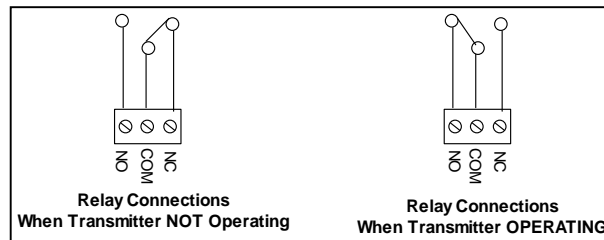

Relay output '1' provides a longer momentary output (approx ½ second) this may be removed by adding Link 6 on the PCB. The outputs are driven from a Microcontroller and can be customised to specific requirements.

Relay Output Configuration

The two option links OPT1, OPT2 (to the left of the antenna connector on the Rx PCB) set the action of the relay outputs according to the following table. Please note that these can be customised on request.

OPT1	OPT2	Relay 4	Relay 3	Relay 2	Relay 1
out	out	½ Sec Momentary	½ Sec Momentary	½ Sec Momentary	Momentary
in	out	Momentary	Momentary	Momentary	Momentary
out	in	Latching	Latching	Latching	Latching
in	in	Test Mode			

TRAP REMOTE CONTROL SYSTEMS (SW ADDRESSING)

Notes for use when Connecting the Remote Control System to a Clay Trap Release

This system is supplied complete with cable in order to connect to the Clay Trap Release.

Warning : Not all Clay Traps have the same wiring convention!

The system is pre-wired (as diagram below) to operate with most trap releases, before connecting, CHECK YOUR CONNECTIONS. (using a voltmeter) if you are in any doubt, DO NOT CONNECT THE SYSTEM, consult a qualified Electrician. Although the system operates on 12/24V damage may occur to the receiver unit if wrong connections are made.

Installation Notes

1. Connect Power to the Receiver unit.

The receiver unit requires the following connections to operate

12V supply (Brown wire as supplied)

0V Supply (Yell/GRN wire as supplied)

These may not match the wire colours on your Trap!

2. When the Receiver unit has power connected the Power LED will illuminate. This must be 'on' for the system to operate.

3. Check operation of the Remote Control

4. When the power LED is 'on' the Remote Control System may be operated, Check operation by firing the transmitter and check that;

- The LED on the transmitter illuminates
- The Rx Data LED on the Receiver unit (next to the power LED) illuminates.

If this does not work then check your Switch addresses on the transmitter and receiver.

5. Check the Wiring to the Trap

6. The receiver has been pre-wired to the following Circuit

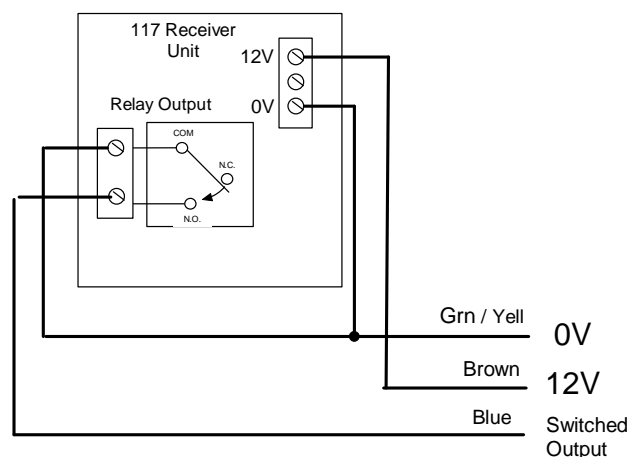

7. When operated, the receiver provides an output (Blue Wire) which momentarily connects to 0V.

8. **Alternative Wiring :** The switched output may be connected in several ways, please see the 'Relay Output Connections' section. If in doubt consult a qualified electrician.



TRAP REMOTE CONTROL SYSTEMS (SW ADDRESSING)

Technical Specifications

Dimension	Transmitter Unit	Decoder Unit
Length	90	110mm (not including ANT)
Width	45	85mm
Height	35	35mm
Rating	IP40	IP65

Transmitter Unit

Storage Temperature: -10 to +70° Celsius. Operating Temperature: 0 to +55° Celsius.

Electrical Characteristics	Min	Typical	Max	Dimension
Supply Voltage	7	9	16	V
Supply Current		10		mA
Frequency		434.075		MHz
RF Output Power (ERP)	-	3		mW
Frequency Accuracy over Full Temp Range			+/-5	KHz

Receiver Unit

Storage Temperature: -10 to +70° Celsius. Operating Temperature: 0 to +55° Celsius.

Electrical Characteristics	Min	Typical	Max	Dimension
Supply Voltage for +12 v	9	12.0	16	V
Supply Current :				
FM Quiescent		19		mA
FM all relays operating		260	275	mA
Relay Rating (Rlys 1-4) (@ 12Vdc)				
@ 12V			2	A
@ 50V			1	A
Relay Rating (RLY Alternative) (@ 50Vdc)				
@ 230Vac			1	A

For more information or general enquiries, please contact

**R. F. Solutions Ltd.,
Unit 21, Cliffe Industrial Estate,
South Street,
Lewes,
E Sussex, BN8 6JL. England**

Tel +44 (0)1273 898 000 Fax +44 (0)1273 480 661

Email sales@rfsolutions.co.uk

<http://www.rfsolutions.co.uk>

RF Solutions is a member of the Low Power Radio Association

Information contained in this document is believed to be accurate, however no representation or warranty is given and R.F. Solutions Ltd. assumes no liability with respect to the accuracy of such information. Use of R.F.Solutions as critical components in life support systems is not authorised except with express written approval from R.F.Solutions Ltd.