

11-MD142

Version : A.003
Issue Date : 2005/11/7
File Name : SP-MD142-A.003.doc
Total Page : 11

Multi-Channels Motor Driver For DSC



新竹市展業一路9號7樓之1

SILICON TOUCH TECHNOLOGY INC.

9-7F-1, Prosperity Rd I, Science-Based Industrial Park

Hsinchu, Taiwan, R.O.C.

Tel : 886-3-5645656

Fax : 886-3-5645626

11-MD142

Motor Driver For DSC

General Specifications

The 11-MD142 is a 4-channels motor driver for Digital Still Camera. It contains constant current control for M-shutter and saturation voltage control channels for AF stepping motor and Iris. It is optimal for DSC Lens module in M-shutter, Iris and Auto Focus motor.

Features and Benefits

- Low voltage operation
- Low saturation voltage
- Low input current
- Easy constant current control
- Ultra low standby current
- Reference Voltage inside (Vref=1.23V)
- Thermal shutdown protection
- Thin, highly reliable package :QFN-32(4.75mm X 4.75mm) and TSSOP-20

Pin Assignment

Pin Assignment of QFN-32

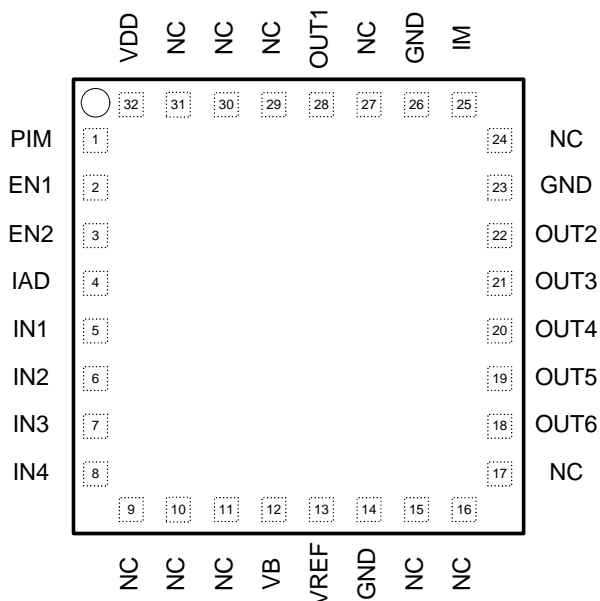

Pin Assignment of TSSOP-20

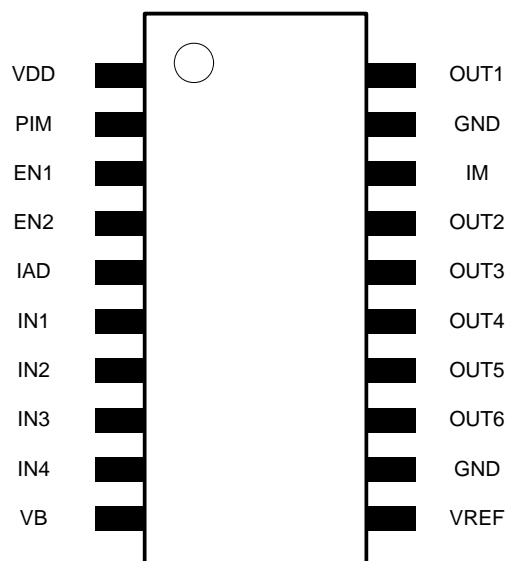

Pin Descriptions of QFN-32

Pin NO.	Pin Name	Description	Pin NO.	Pin Name	Description
1	PIM	Current sense resistor	17	NC	
2	EN1	Mode Selected Input pin	18	OUT6	Motor output pin
3	EN2	Mode Selected Input pin	19	OUT5	Motor output pin
4	IAD	AMP positive input pin	20	OUT4	Motor output pin
5	IN1	Motor control input pin	21	OUT3	Motor output pin
6	IN2	Motor control input pin	22	OUT2	Motor output pin
7	IN3	Motor control input pin	23	GND	Controller and driver ground
8	IN4	Motor control input pin	24	NC	
9	NC		25	IM	Current sense resistor
10	NC		26	GND	Controller and driver ground
11	NC		27		
12	VB	Power supply pin for motor driver	28	OUT1	Motor output pin
13	VREF	Reference voltage output pin	29	NC	
14	GND	Motor driver ground	30	NC	
15	NC		31	NC	
16	NC		32	VDD	Power supply pin for controller.

Pin Descriptions of TSSOP-20

Pin NO.	Pin Name	Description	Pin NO.	Pin Name	Description
1	VDD	Power supply pin for controller.	11	VREF	Reference voltage output pin
2	PIM	Current sense resistor	12	GND	Motor driver ground
3	EN1	Mode selected Input pin	13	OUT6	Motor output pin
4	EN2	Mode selected Input pin	14	OUT5	Motor output pin
5	IAD	AMP positive input pin	15	OUT4	Motor output pin
6	IN1	Motor control input pin	16	OUT3	Motor output pin
7	IN2	Motor control input pin	17	OUT2	Motor output pin
8	IN3	Motor control input pin	18	IM	Current sense resistor
9	IN4	Motor control input pin	19	GND	Controller and driver ground
10	VB	Power supply pin for motor driver	20	OUT1	Motor output pin



Absolute Maximum Ratings (Unless otherwise noted, $T_A = 25^\circ\text{C}$)

Characteristic	Symbol	Rating	Unit
Supply Voltage	V_{DD}	5.5	V
	V_B	5.5	V
Input Voltage	V_{IN}	$V_{DD}+0.4$	V
I_O Peak Current	I_{OPeak}	1.5	A
I_{ODC} Current	I_{ODC}	550	mA
Power Dissipation	P_D	800	mW
Operating Temperature Range	T_{OPR}	-40 ~ 125	$^\circ\text{C}$
Storage Temperature Range	T_{STG}	-65 ~ 150	$^\circ\text{C}$

Electrical Characteristic

(Unless otherwise noted, $T_A = 25^\circ\text{C}$, $R_a + R_b = 10\text{ k}\Omega$ & $V_{DD} = V_B = 3\text{V}$)

Characteristic	Sym.	Condition	Limit			Unit
			Min.	Typ.	Max.	
Supply Voltage	V_{DD}		2.2	3	5.5	V
	V_B		-	3	5.5	V
Supply Current (I_{DD})	I_{STB}	$V_{EN1-EN2} = L$; $V_{IN1-IN4} = L$	-	0.1	1	μA
	I_{DD1}	$V_{EN1-EN2} = LH$	-	0.8	1.5	mA
	I_{DD2}	$V_{EN1-EN2} = HL$	-	0.6	1.0	mA
	I_{DD3}	$V_{EN1-EN2} = HH$	-	0.6	1.0	mA
Reference Voltage Circuit						
Reference Voltage	V_{ref}	$V_{DD} = 3\text{V}$; $I_{ref} = -1\text{mA}$	1.19	1.23	1.27	V
EN1~2 / IN1~4 Input Terminal ($T_J = 25^\circ\text{C}$)						
Input Voltage "H"	V_{IH}	-	$0.8 \cdot V_{DD}$	-	$V_{DD}+0.4$	V
Input Voltage "L"	V_{IL}	-	-0.4	-	$0.2 \cdot V_{DD}$	V
Input Current "H"	I_{IH}	$V_{IN} = V_{DD}$	-	-	± 5	μA
Input Current "L"	I_{IL}	$V_{IN} = 0\text{V}$	-	-	± 5	μA
AF Output Terminal (OUT2-3 , OUT5-6)						
Saturation Voltage (upper + lower)	V_{SAT1}	$I_{OUT} = 200\text{ mA}$	-	0.25	0.4	V
AE Output Terminal (OUT4-5)						
Saturation Voltage (upper + lower)	V_{SAT2}	$I_{OUT} = 200\text{ mA}$	-	0.25	0.4	V



SH Output Terminal (OUT1-2)						
Output Current1	I_{O1}	O2-> O1, $R_{IM} = 1\Omega$ $V_{IAD}=0.3V$	255	270	285	mA
Output Current1	I_{O2}	O1-> O2, $R_{PIM} = 0.9\Omega$ $V_{IAD}=0.3V$	220	248	275	mA
Saturation Voltage (upper + lower)	V_{SAT3}	$I_{OUT} = 200\text{ mA}$	-	0.25	0.4	V
Thermal Protection Circuit						
Protection Temperature	T_{TSD}	V_{EN1} or $V_{EN2}=H$	-	160	-	°C

Truth Table

INPUT						OUPUT						MODE		
EN1	EN2	IN1	IN2	IN3	IN4	O1	O2	O3	O4	O5	O6			
L	L	—	—	—	—	—	—	—	—	—	—	STB		
L	H	L	L	—	—	—	—	—	—	—	—	SH		
		L	H			L	H	—					—	
		H	L			H	L	—					—	
		H	H			—	—	—					—	
		—	—	L	L	—	—	—	—	—	—		—	—
				L	H			—	—	L	H		—	
				H	L			—	—	H	L		—	
				H	H			—	—	—	—		—	
H	L	L	L	—	—	—	—	—	—	—	—	AE (VCM)		
		L	H			—	—	L					—	—
		H	L			—	—	H					—	—
		H	H			—	—	—					—	—
		—	—	L	L	—	—	—	—	—	—		—	—
				L	H			—	—	L	H		—	
				H	L			—	—	H	L		—	
				H	H			—	—	—	—		—	
H	H	L	L	—	—	—	—	—	—	—	—	AF (STM)		
		L	H			—	L	H					—	
		H	L			—	H	L					—	
		H	H			—	—	—					—	
		—	—	L	L	—	—	—	—	—	—		—	—
				L	H			—	—	L	H		—	
				H	L			—	—	H	L		—	
				H	H			—	—	—	—		—	

Note: “*”: Don't care; “—”: High Impedance

Application Circuit

- **AF:** Saturation drive for 2 phase, 1-2 phase stepping motor
- **M-shutter:** Constant current drive for shutter voice coil motor
- **Aperture:** Saturation drive for aperture voice coil motor

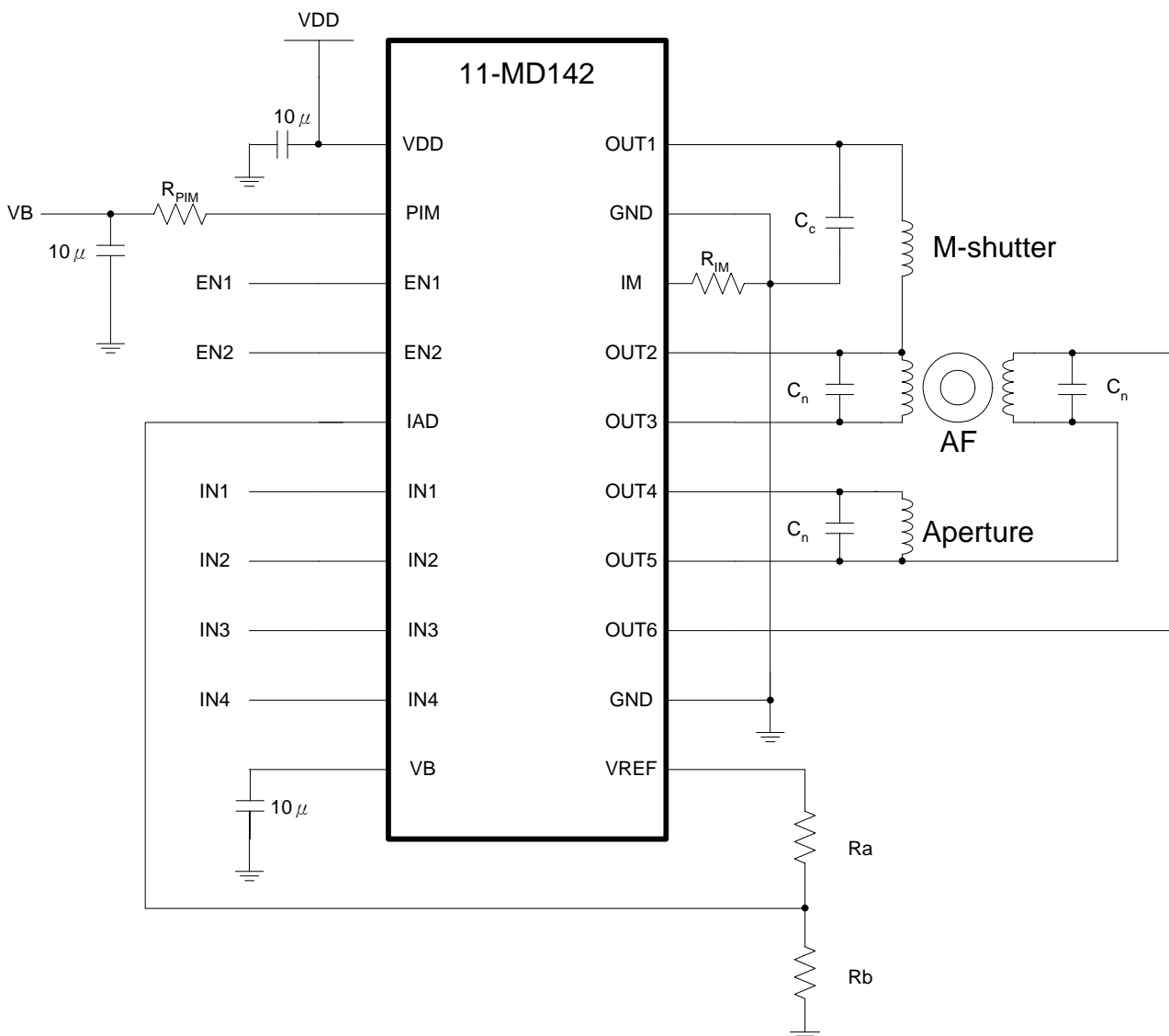



Function Block (TSSOP-20 Pin Assignment)

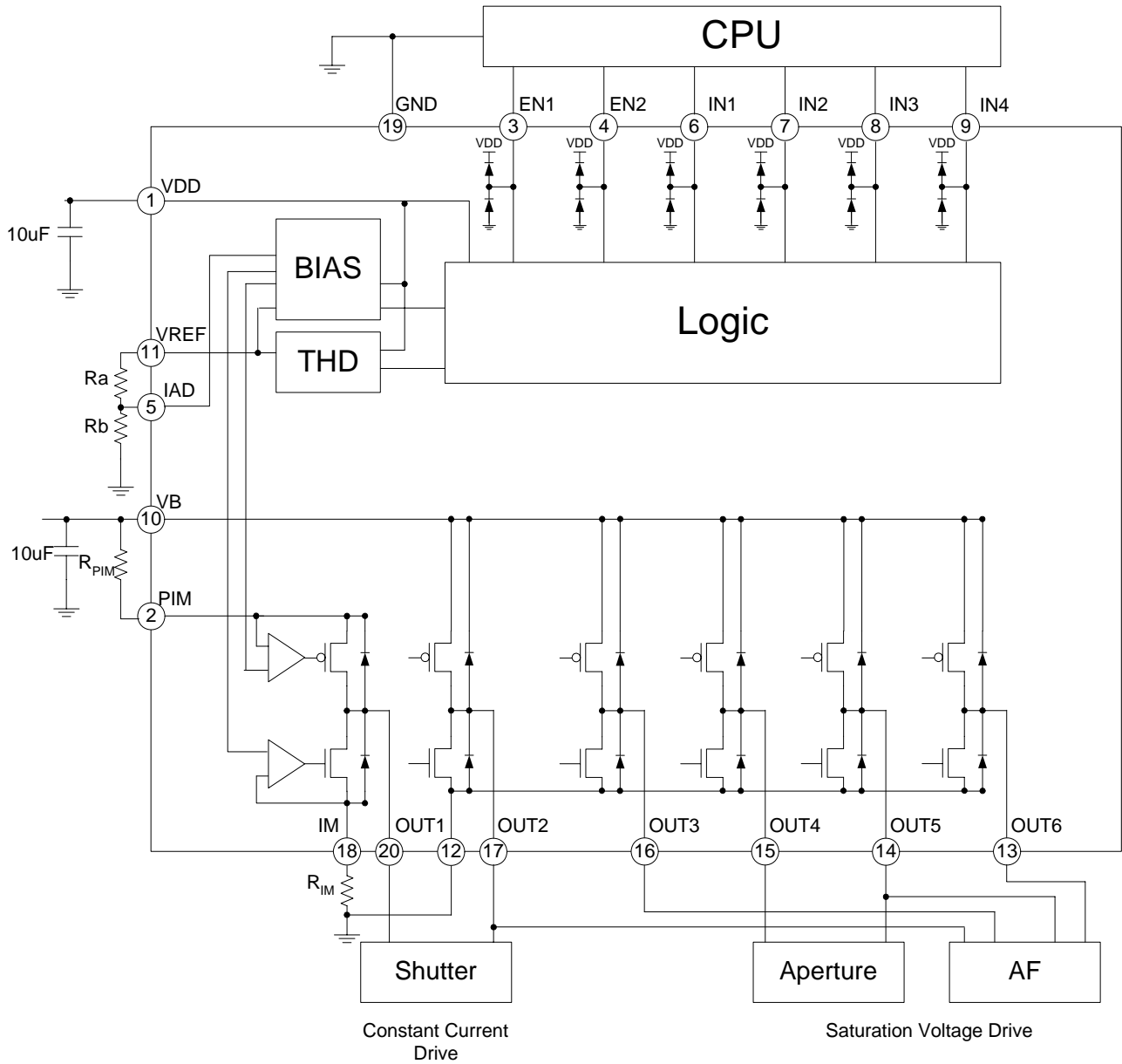

Application Notes

- The 11-MD142 integrates saturation voltage and constant current of motor driver. The range of supply voltage of 11-MD142, VDD and VB, is from 2.2V to 5.5V. The 11-MD142 input range is defined that logic “H” is from $0.8 \cdot VDD$ to $VDD + 0.4V$ and logic “L” is from $-0.4V$ to $0.2 \cdot VDD$. EN1 and EN2 are mode selection pins; IN1, IN2, IN3 and IN4 are motor rotation selection pins.
- Normally VB should provide enough current for output loading, thus large value of C is suggested for the terminal VB. Besides, $0.01\mu F \sim 0.1\mu F$ of capacitors, C_n , are also suggested between each output channel and output channel to ground.
- Constant current operation of 11-MD142 provides the current, which can be evaluated by the following formula (See the depiction of application circuit 1.):

$$I_{PIM} = \frac{V_{IAD}}{(R_{PIM} + 0.3)} \quad (\text{unit : A})$$

$$I_{IM} = \frac{V_{IAD}}{(R_{IM} + 0.11)} \quad (\text{unit : A})$$

- Before switching the mode of actuator, make sure to pull low the motor rotation selection pins (IN1~IN4). Then, switch to next mode to drive the motor.
- Considering of stability of function of constant current, compensation capacitor of C_c ($0.1 \sim 1\mu F$) is suggested to connect between pin OUT1 and IM.

Package Specifications (QFN-32)

TOP VIEW

BOTTOM VIEW

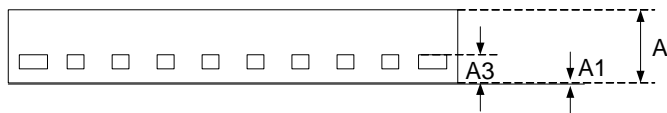
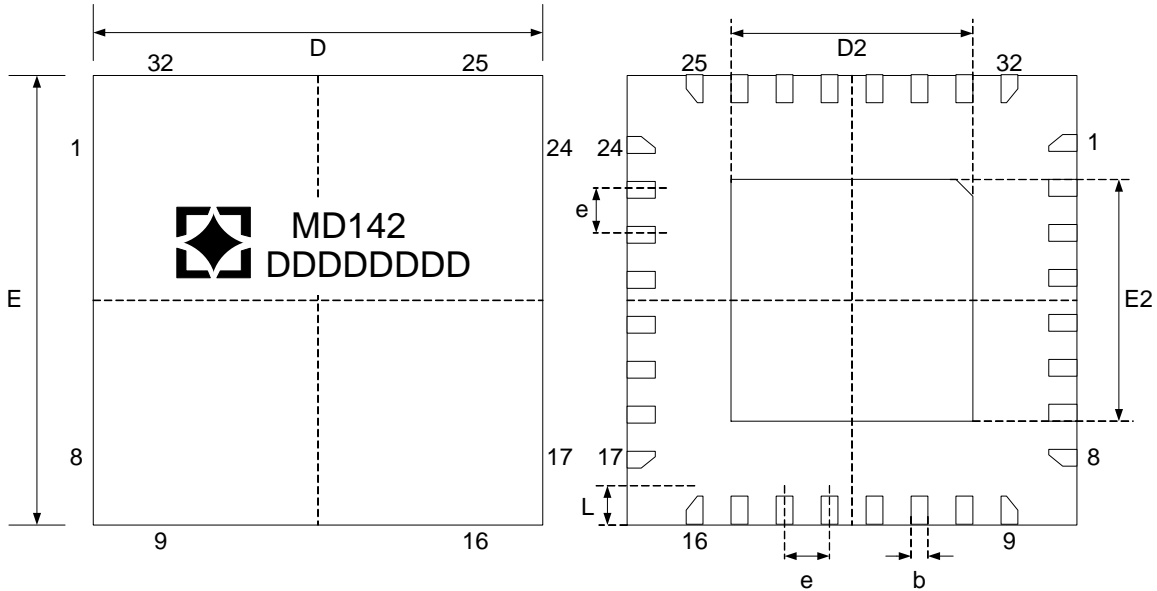

Note: "DDDDDDDD" are the date code or lot number and may be changed.

SYMBOL	Dimensions in Millimeter		
	MIN	NOM	MAX
A	0.70	0.75	0.80
A1	0	0.02	0.05
A3	0.20 REF		
b	0.18	0.25	0.30
D	5.00 BSC		
D2	2.60	2.70	2.80
E	5.00 BSC		
E2	2.60	2.70	2.80
L	0.30	0.40	0.50
e	0.50 BSC		

Package Specifications(TSSOP-20)

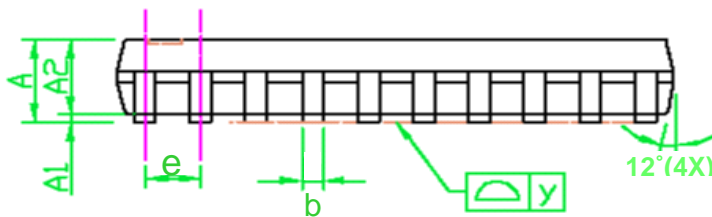
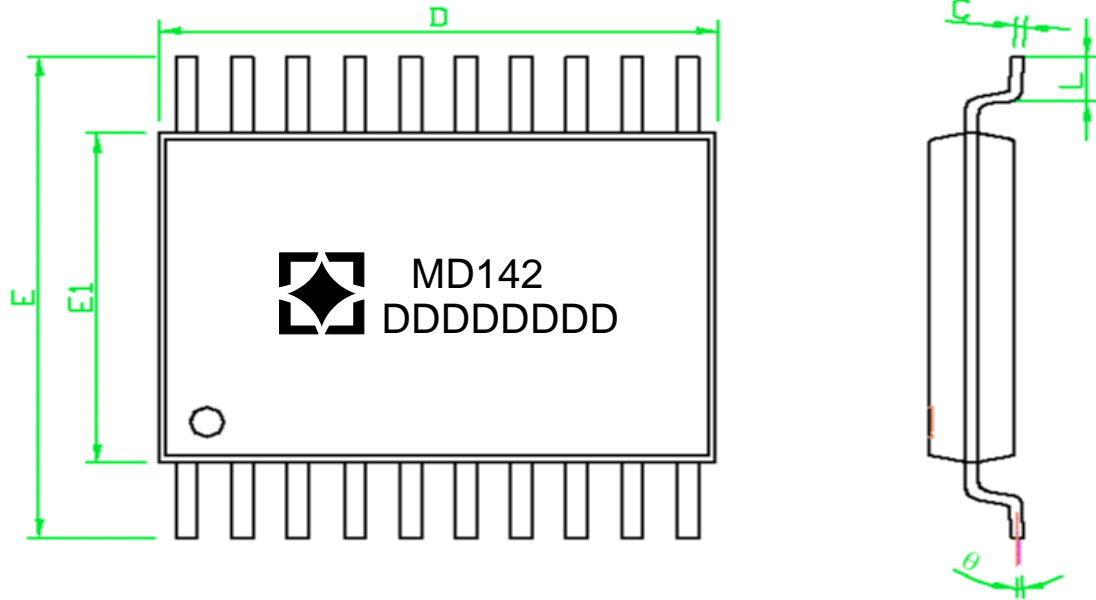

Note: "DDDDDDDD" are the date code or lot number and may be changed.

SYMBOL	Dimensions in Millimeter		
	MIN	NOM	MAX
A	—	—	1.20
A1	0.05	—	0.15
A2	0.80	1	1.05
b	0.19	—	0.30
C	0.09	—	0.20
D	6.40	6.50	6.60
E	6.20	6.40	6.40
E1	4.30	4.40	4.50
e	—	0.65	—
L	0.45	0.60	0.75
y	—	—	0.10
θ	0°	—	8°



The products listed herein are designed for ordinary electronic applications, such as electrical appliances, audio-visual equipment, communications devices and so on. Hence, it is advisable that the devices should not be used in medical instruments, surgical implants, aerospace machinery, nuclear power control systems, disaster/crime-prevention equipment and the like. Misusing those products may directly or indirectly endanger human life, or cause injury and property loss.

Silicon Touch Technology, Inc. will not take any responsibilities regarding the misuse of the products mentioned above. Anyone who purchases any products described herein with the above-mentioned intention or with such misused applications should accept full responsibility and indemnify. Silicon Touch Technology, Inc. and its distributors and all their officers and employees shall defend jointly and severally against any and all claims and litigation and all damages, cost and expenses associated with such intention and manipulation.