

Low Vcesat PNP Epitaxial Planar Transistor

BTB772SA3

Features

- Low VCE(sat), typically -0.3 V at IC / IB = -2A / -0.1A
- Excellent current gain characteristics
- Complementary to BTD882SA3
- Pb-free package

Symbol

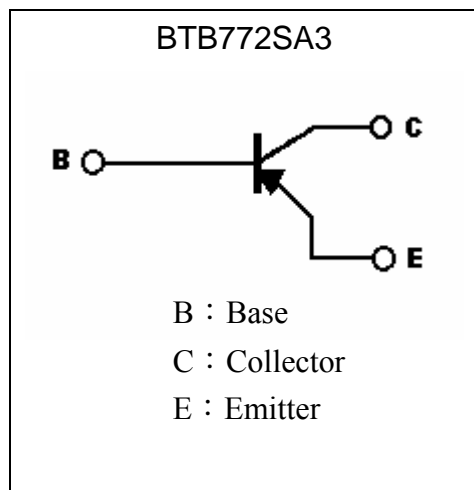

Outline

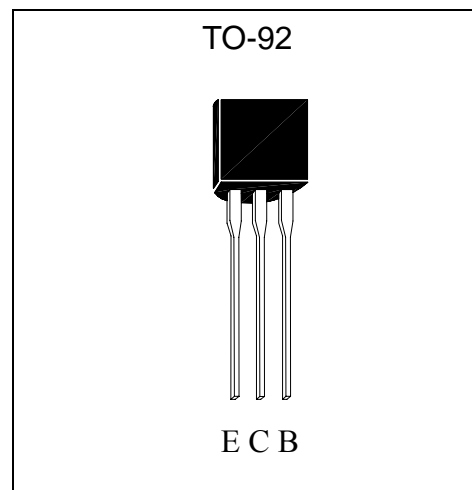

Absolute Maximum Ratings (Ta=25°C)

Parameter	Symbol	Limit	Unit
Collector-Base Voltage	V _{CB0}	-50	V
Collector-Emitter Voltage	V _{CE0}	-50	V
Emitter-Base Voltage	V _{EB0}	-5	V
Collector Current	I _{C(DC)}	-3	A
	I _{C(pulse)}	-7 (Note)	A
Power Dissipation	P _d	750	mW
Junction Temperature	T _j	150	°C
Storage Temperature	T _{stg}	-55~+150	°C

Note : Single Pulse Pw ≤ 350μs, Duty ≤ 2%.

Characteristics (Ta=25°C)

Symbol	Min.	Typ.	Max.	Unit	Test Conditions
BV _{CBO}	-50	-	-	V	I _C =-100μA, I _E =0
BV _{CEO}	-50	-	-	V	I _C =-1mA, I _B =0
BV _{EBO}	-5	-	-	V	I _E =-50μA, I _C =0
I _{CBO}	-	-	-1	μA	V _{CB} =-40V, I _E =0
I _{CEO}	-	-	-1	μA	V _{CE} =-30V, I _B =0
I _{EBO}	-	-	-1	μA	V _{EB} =-5V, I _C =0
*V _{CE(sat)}	-	-	-0.3	V	I _C =-400mA, I _B =-20mA
*V _{CE(sat)}	-	-0.3	-0.5	V	I _C =-2A, I _B =-0.1A
*V _{BE(sat)}	-	-1	-2	V	I _C =-2A, I _B =-0.2A
*h _{FE1}	100	-	-	-	V _{CE} =-2V, I _C =-20mA
*h _{FE2}	160	-	-	-	V _{CE} =-2V, I _C =-100mA
*h _{FE3}	160	-	500	-	V _{CE} =-2V, I _C =-500mA
*h _{FE4}	100	-	-	-	V _{CE} =-2V, I _C =-1A
f _T	-	80	-	MHz	V _{CE} =-5V, I _C =-0.1A, f=100MHz
Cob	-	55	-	pF	V _{CB} =-10V, f=1MHz

*Pulse Test : Pulse Width ≤380μs, Duty Cycle≤2%

Classification Of hFE 3

Rank	P	E
Range	160~320	250~500

Characteristic Curves

Current gain vs Collector current

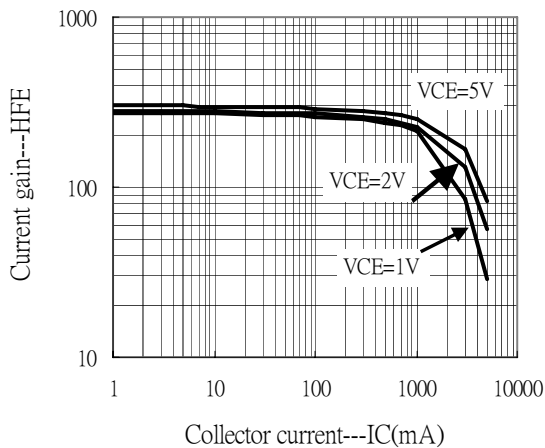

C-E saturation voltage vs Collector current

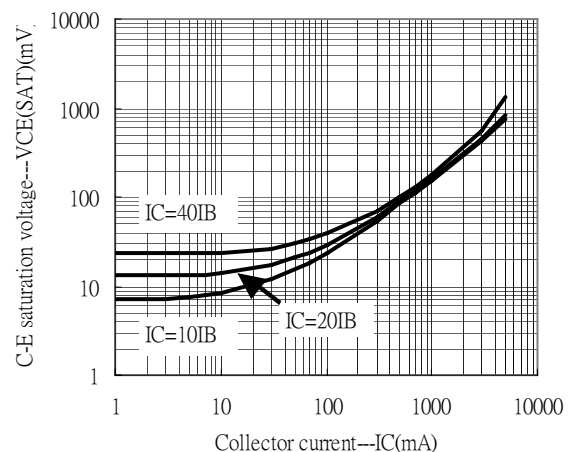



B-E saturation voltage vs Collector current

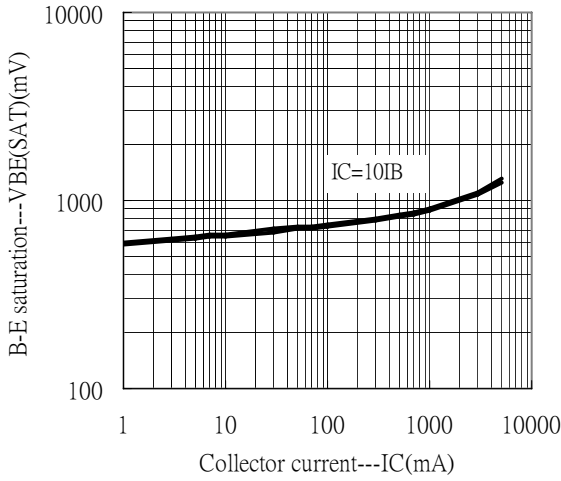

Power Derating Curve

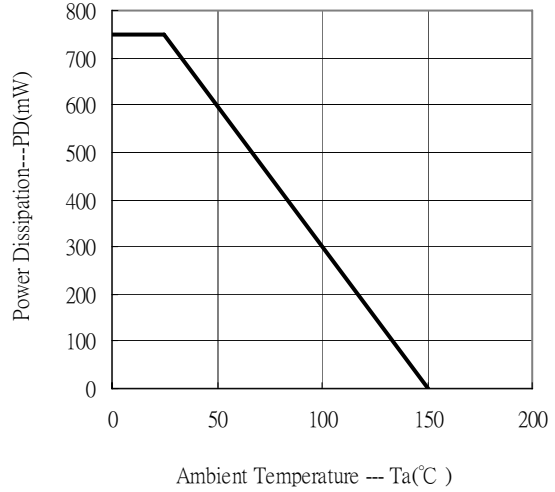

Grounded Emitter Propagation Characteristics

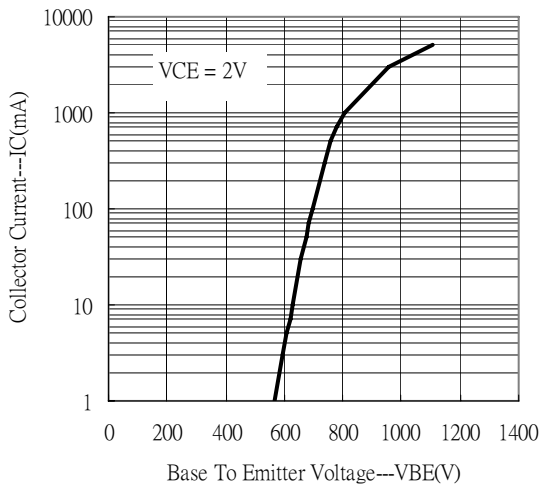

Grounded Emitter Output Characteristics

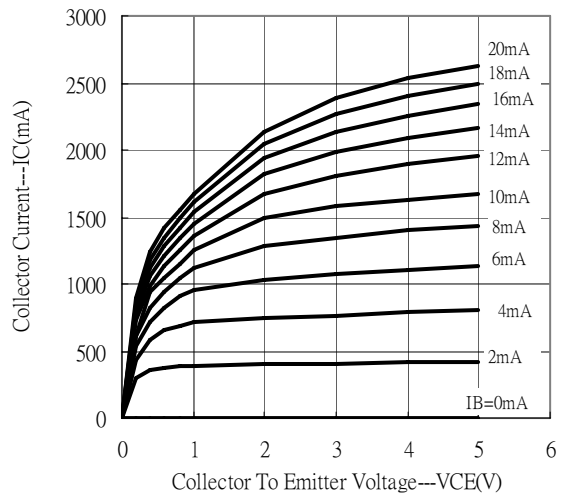

Grounded Emitter Output Characteristics

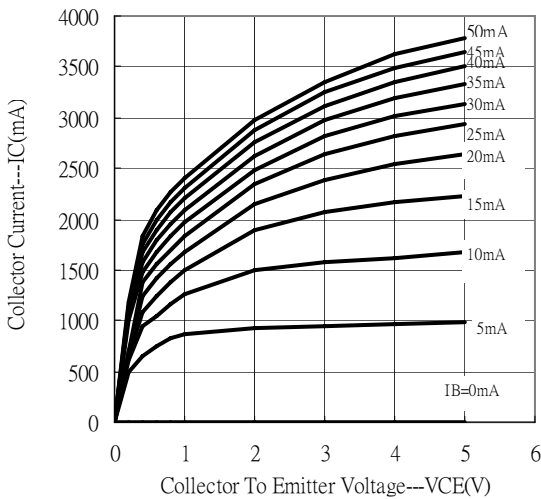

TO-92 Dimension

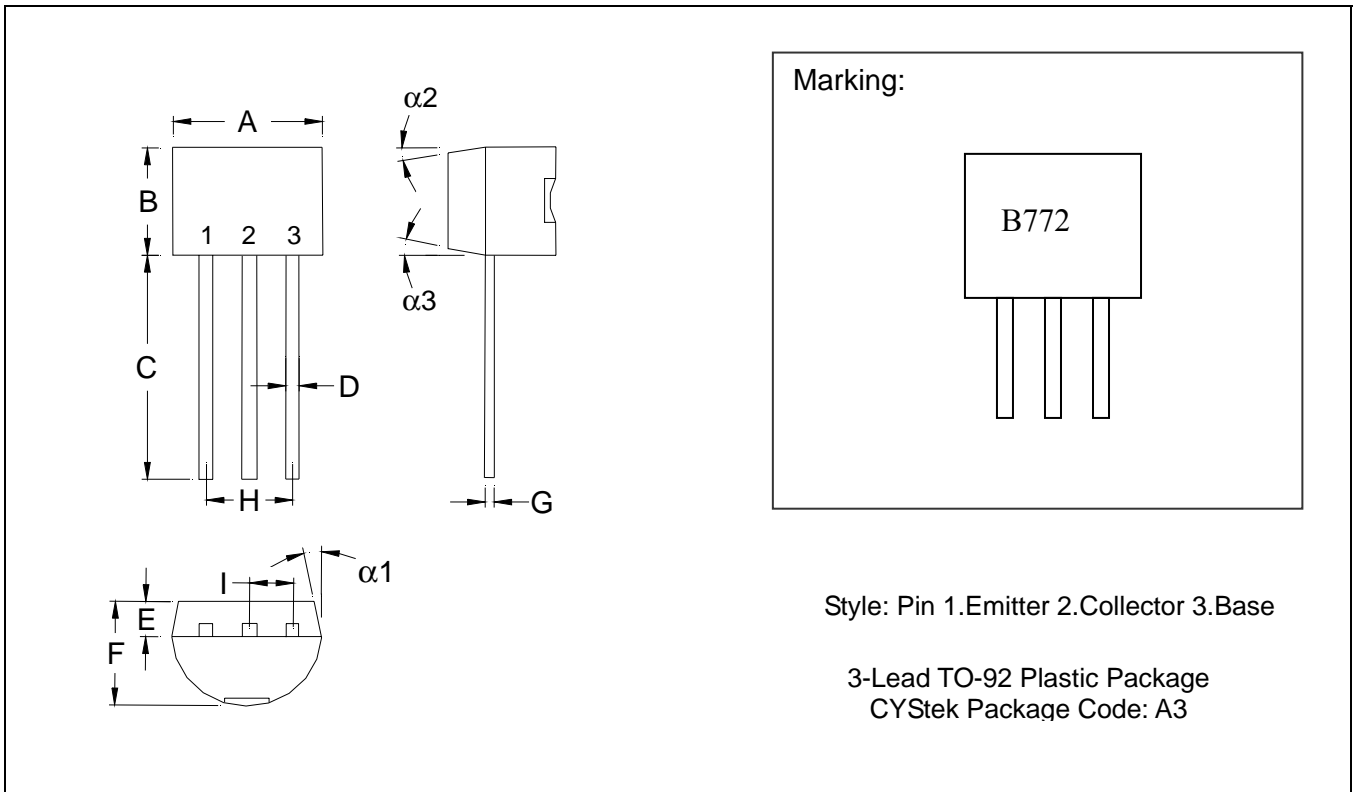

*: Typical

DIM	Inches		Millimeters		DIM	Inches		Millimeters	
	Min.	Max.	Min.	Max.		Min.	Max.	Min.	Max.
A	0.1704	0.1902	4.33	4.83	G	0.0142	0.0220	0.36	0.56
B	0.1704	0.1902	4.33	4.83	H	-	*0.1000	-	*2.54
C	0.5000	-	12.70	-	I	-	*0.0500	-	*1.27
D	0.0142	0.0220	0.36	0.56	$\alpha 1$	-	*5°	-	*5°
E	-	*0.0500	-	*1.27	$\alpha 2$	-	*2°	-	*2°
F	0.1323	0.1480	3.36	3.76	$\alpha 3$	-	*2°	-	*2°

Notes: 1. Controlling dimension: millimeters.
 2. Maximum lead thickness includes lead finish thickness, and minimum lead thickness is the minimum thickness of base material.
 3. If there is any question with packing specification or packing method, please contact your local CYStek sales office.

Material:

- Lead: KFC ; pure tin plated
- Mold Compound: Epoxy resin family, flammability solid burning class: UL94V-0

Important Notice:

- All rights are reserved. Reproduction in whole or in part is prohibited without the prior written approval of CYStek.
- CYStek reserves the right to make changes to its products without notice.
- CYStek **semiconductor products are not warranted to be suitable for use in Life-Support Applications, or systems.**
- CYStek assumes no liability for any consequence of customer product design, infringement of patents, or application assistance.