

## Features

- Integrated Logic
- Positive Single Control
- Insertion Loss: 1.3 dB @ 1.0 GHz
- IP3: 42 dBm typical @ 2.0 GHz
- Attenuation Accuracy: 0.2 dB + 2% @ 1.0 GHz
- 2-dB Attenuation Steps to 30 dB
- Low DC Power Consumption
- Lead-Free 3mm PQFN-16LD Plastic Package
- Halogen-Free “Green” Mold Compound
- RoHS\* Compliant and 260°C Re-flow Compatible

## Description

The MAADSS0014 is a 4-Bit, 2dB step GaAs MMIC digital attenuator in a lead-free 3mm PQFN-16LD surface mount plastic package. The MAADSS0014 is ideally suited for use where high accuracy, very low power consumption and low intermodulation products are required. Typical applications include radio, cellular, wireless LANs, GPS equipment and other gain / level control circuits.

The MAADSS0014 is part of a digital attenuator family. This family includes 4, 5, and 6 bit attenuators with 0.5, 1, or 2 dB steps and up to 31.5 range.

## Ordering Information <sup>1,2</sup>

Part Number	Package
MAADSS0014TR-1000	1000 piece reel
MAADSS0014TR-3000	3000 piece reel
MAADSS0014SMB	Sample Board

1. Reference Application Note M513 for reel size information.
2. All sample boards include 5 loose parts.

## Functional Schematic <sup>3,4</sup>

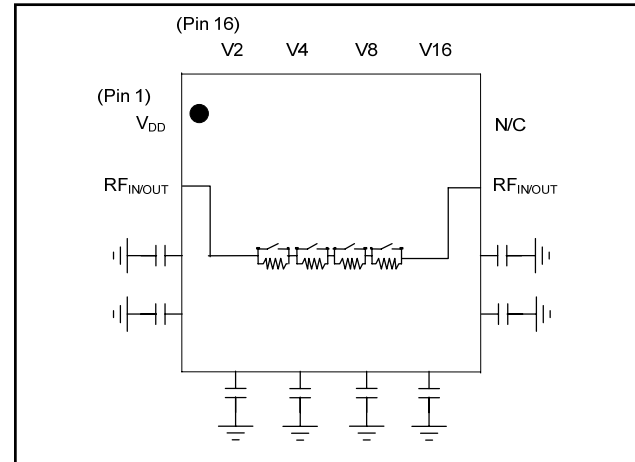

3. Blocking capacitors are required on all RF ports.
4. RF Port and Ground pin capacitors are 1000 pF.

## Pin Configuration <sup>5</sup>

Pin No.	Function	Pin No.	Function
1	V <sub>DD</sub>	9	Ext. C to GND
2	RF In/Out	10	Ext. C to GND
3	Ext. C to GND	11	RF In/Out
4	Ext. C to GND	12	N/C or GND
5	Ext. C to GND	13	V16 (16dB Bit)
6	Ext. C to GND	14	V8 (8dB Bit)
7	Ext. C to GND	15	V4 (4dB Bit)
8	Ext. C to GND	16	V2 (2dB Bit)

5. The exposed pad centered on the package bottom should be grounded.

## Absolute Maximum Ratings <sup>6,7</sup>

Parameter	Absolute Maximum
Input Power 0.5 - 4.0 GHz	+33 dBm
Control Voltage	-0.5 V ≤ V <sub>C</sub> ≤ 5.5 V
Operating Temperature	-40°C to +85°C
Storage Temperature	-65°C to +150°C

6. Exceeding any one or combination of these limits may cause permanent damage to this device.
7. M/A-COM Technology does not recommend sustained operation near these survivability limits.

\* Restrictions on Hazardous Substances, European Union Directive 2002/95/EC.

## Digital Attenuator, 4-Bit, Single Control 30 dB, 0.05 - 4.0 GHz

Rev. V2

### Electrical Specifications<sup>8,9</sup>: $T_A = 25^\circ\text{C}$ , $Z_0 = 50\ \Omega$ , $V_{DD} = 5\ \text{V}$ , $V_C = 2.8\ \text{V}$

Parameter	Test Conditions	Units	Min.	Typ.	Max.
Reference Insertion Loss	1.0 GHz	dB	—	1.3	1.7
Attenuation Accuracy	1.0 GHz	$\pm (0.2\ \text{dB} + 2\% \text{ of attenuation setting in dB})\ \text{dB}$			
VSWR	0.05 - 4.0 GHz	Ratio	—	1.5:1	—
Trise, Tfall	10% to 90% RF, 90% to 10% RF	ns	—	40	—
Ton, Toff	50% Control to 90% RF, 50% Control to 10% RF	ns	—	65	—
Transients	In Band	mV	—	75	—
Input P1dB	2.0 GHz	dBm	—	30	—
Input IP <sub>2</sub>	2-Tone, +5 dBm/tone, 1 MHz Spacing 0.5 GHz 2.0 GHz	dBm	—	75	—
			—	80	—
Input IP <sub>3</sub>	2-Tone, +5 dBm/tone, 1 MHz Spacing 0.5, 2.0 GHz	dBm	—	42	—
			—	—	—
I <sub>C</sub>	V <sub>C</sub> = 2.8 V	$\mu\text{A}$	—	15	25
I <sub>DD</sub>	V <sub>DD</sub> = 5 V	$\mu\text{A}$	—	170	250

8. External DC blocking capacitors are required on all RF ports.

9. Low frequency is determined by DC block and GND capacitor value

### Truth Table<sup>10</sup>

VC2	VC4	VC8	VC16	Attenuation (dB)
0	0	0	0	Reference IL
1	0	0	0	2
0	1	0	0	4
0	0	1	0	8
0	0	0	1	16
1	1	1	1	30

10. 0 =  $0 \pm 0.2\ \text{V}$ , 1 = +2.8 to 5 V.

### Handling Procedures

Please observe the following precautions to avoid damage:

### Static Sensitivity

Gallium Arsenide Integrated Circuits are sensitive to electrostatic discharge (ESD) and can be damaged by static electricity. Proper ESD control techniques should be used when handling these devices.

### Recommended PCB

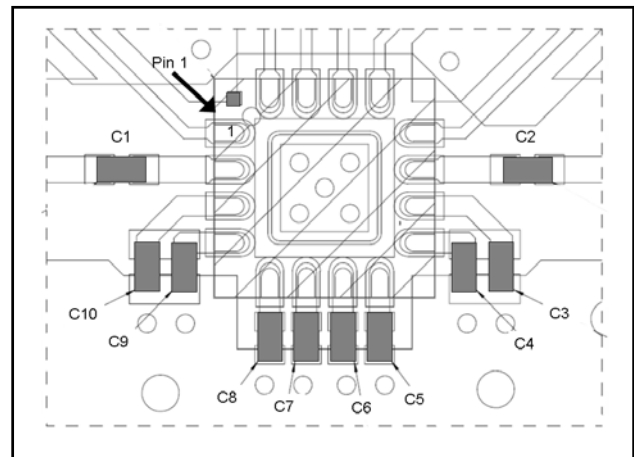

### Off-Chip Component Values

Component	Value	Package
C1 - C10	1000 Pf	0201

## Typical Performance Curves

**Insertion Loss**

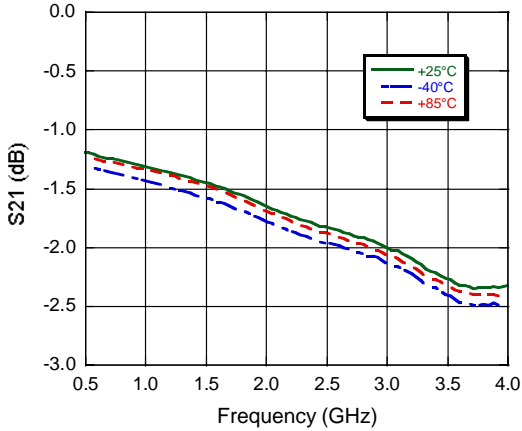

**Relative Attenuation across all major states**

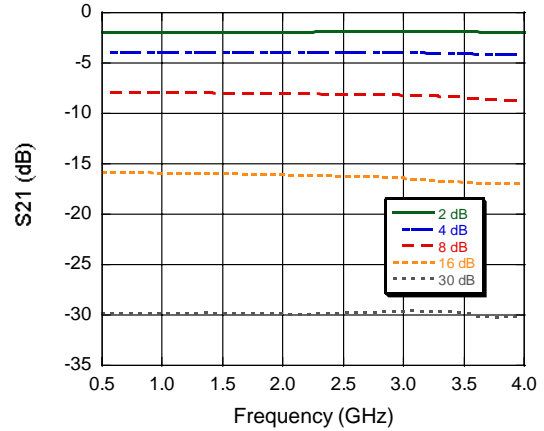

**Input Return Loss, Insertion Loss State**

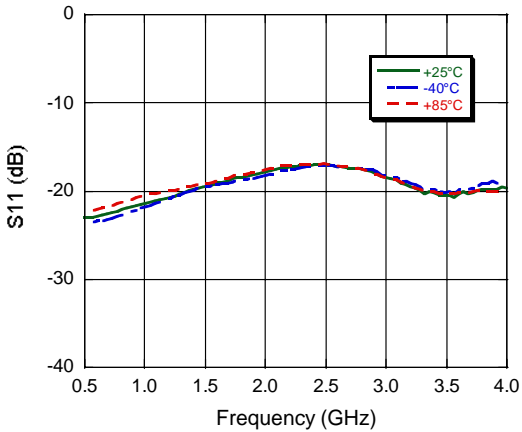

**Input Return Loss, across all major attenuation states**

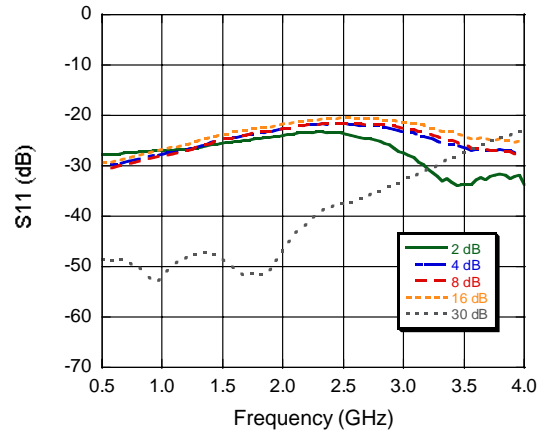

**Output Return Loss, Insertion Loss State**

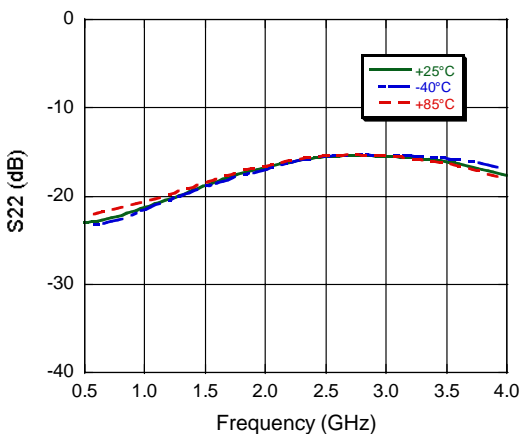

**Output Return Loss, across all major attenuation states**

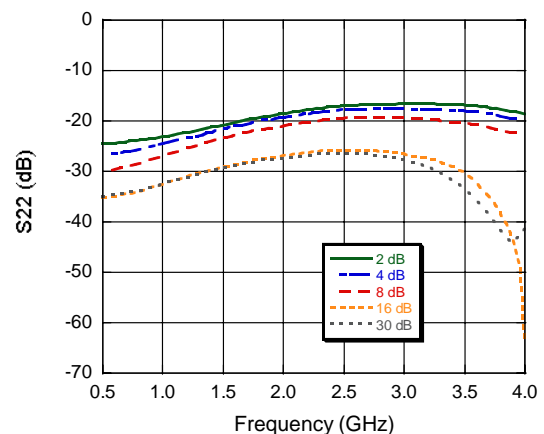

## Typical Performance Curves

Input IP3 @ 0.5 GHz

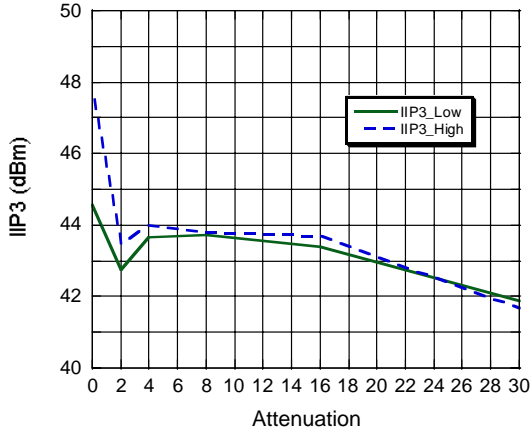

Input IP3 @ 2 GHz

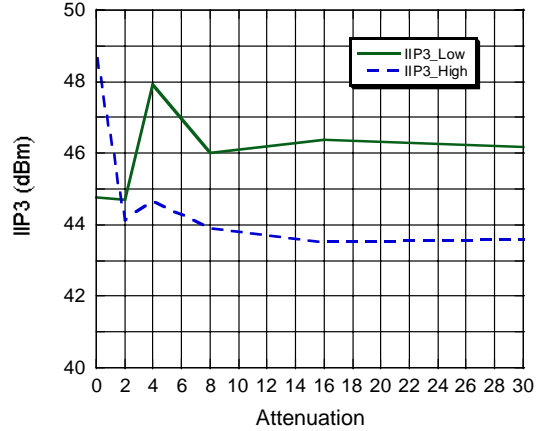

## Lead Free 3 mm 16-Lead PQFN †

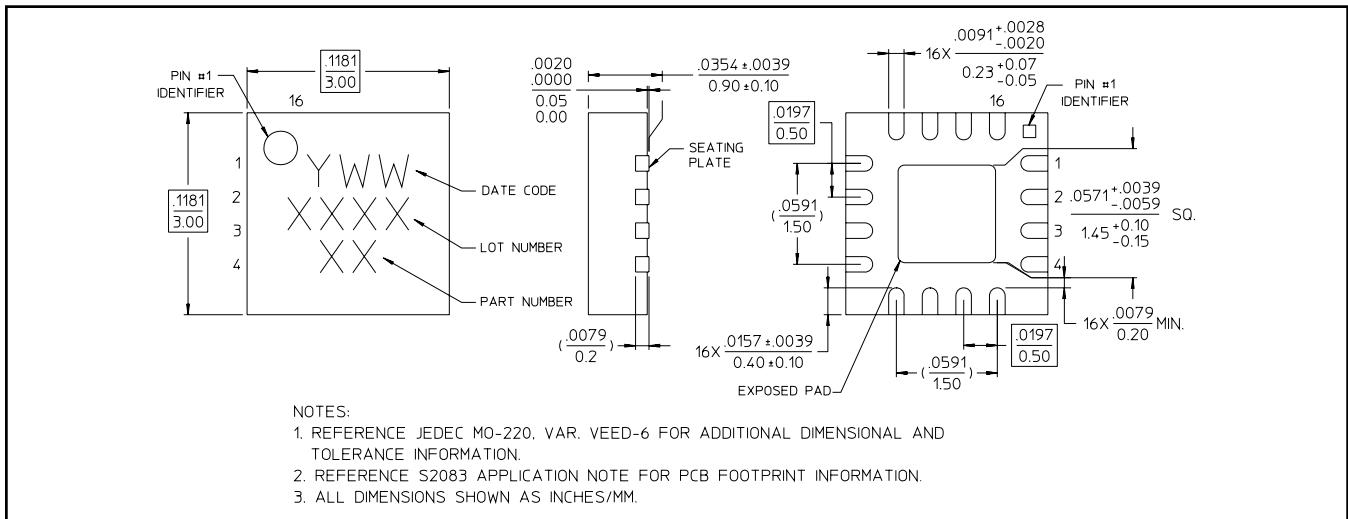

† Reference Application Note S2083 for lead-free solder reflow recommendations.  
Meets JEDEC moisture sensitivity level 1 requirements.  
Plating is 100% matte tin over copper.