

Silicon PNP Power Transistors

2SB1342

DESCRIPTION

- With TO-220Fa package
- High DC current gain
- Low saturation voltage
- DARLINGTON

APPLICATIONS

- For low frequency power amplifier and power driver applications

PINNING

PIN	DESCRIPTION
1	Base
2	Collector
3	Emitter

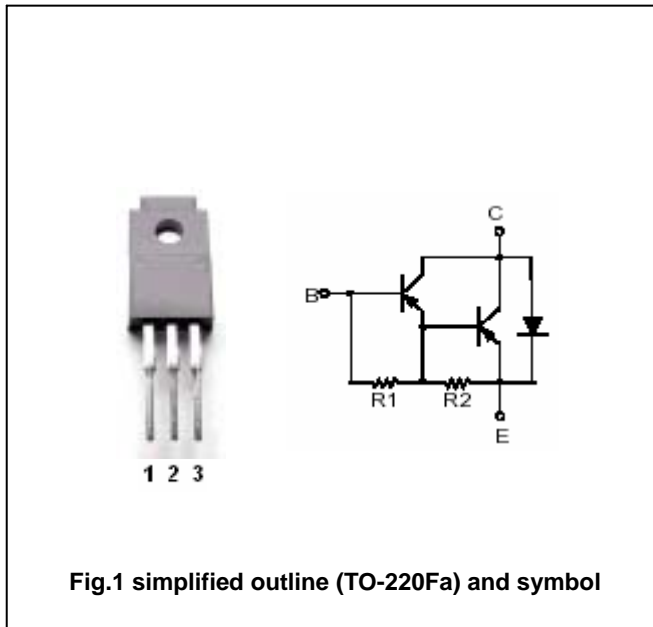

Fig.1 simplified outline (TO-220Fa) and symbol

Absolute maximum ratings(Ta=25 )

SYMBOL	PARAMETER	CONDITIONS	VALUE	UNIT
V <sub>CBO</sub>	Collector-base voltage	Open emitter	-80	V
V <sub>CEO</sub>	Collector -emitter voltage	Open base	-80	V
V <sub>EBO</sub>	Emitter-base voltage	Open collector	-7	V
I <sub>C</sub>	Collector current		-4	A
I <sub>CM</sub>	Collector current-peak		-6	A
P <sub>C</sub>	Collector power dissipation	T <sub>a</sub> =25	2	W
		T <sub>C</sub> =25	30	
T <sub>j</sub>	Junction temperature		150	
T <sub>stg</sub>	Storage temperature		-55~150	

## Silicon PNP Power Transistors

2SB1342

## CHARACTERISTICS

T<sub>j</sub>=25 unless otherwise specified

SYMBOL	PARAMETER	CONDITIONS	MIN	TYP.	MAX	UNIT
V <sub>(BR)CEO</sub>	Collector-emitter breakdown voltage	I <sub>C</sub> =-1mA; I <sub>B</sub> =0	-80			V
V <sub>(BR)CBO</sub>	Collector-base breakdown voltage	I <sub>C</sub> =-50 μA; I <sub>E</sub> =0	-80			V
V <sub>CEsat</sub>	Collector-emitter saturation voltage	I <sub>C</sub> =-2A; I <sub>B</sub> =-4mA		-1.0	-1.5	V
I <sub>CBO</sub>	Collector cut-off current	V <sub>CB</sub> =-80V; I <sub>E</sub> =0			-100	μA
I <sub>EBO</sub>	Emitter cut-off current	V <sub>EB</sub> =-5V; I <sub>C</sub> =0			-3.0	mA
h <sub>FE</sub>	DC current gain	I <sub>C</sub> =-2A; V <sub>CE</sub> =-3V	1000		10000	
f <sub>T</sub>	Transition frequency	I <sub>C</sub> =-0.5A; V <sub>CE</sub> =-5V		12		MHz
C <sub>OB</sub>	Output capacitance	I <sub>E</sub> =0; V <sub>CB</sub> =-10V; f=1MHz		45		pF

PACKAGE OUTLINE

