

Silicon PNP Power Transistors

BDW94/A/B/C

DESCRIPTION

- With TO-220C package
- High DC Current Gain
- DARLINGTON
- Complement to type BDW93/A/B/C

APPLICATIONS

- Hammer drivers,
- Audio amplifiers applications

PINNING

PIN	DESCRIPTION
1	Base
2	Collector;connected to mounting base
3	Emitter

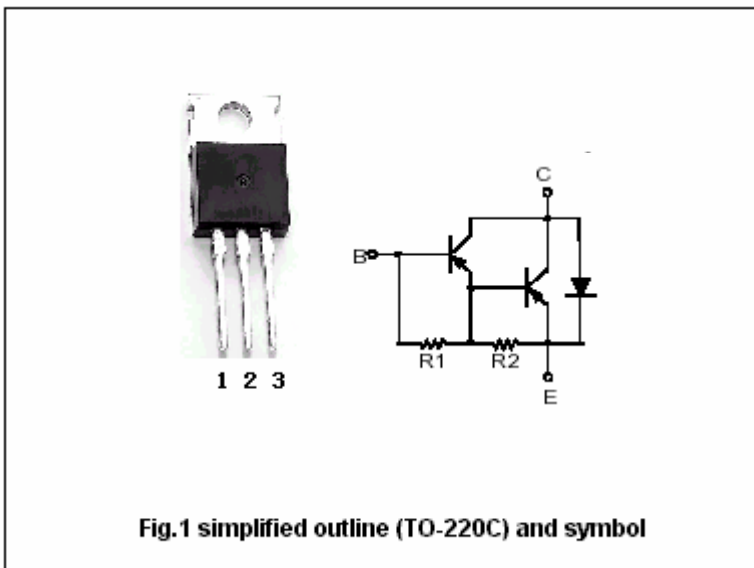

Fig.1 simplified outline (TO-220C) and symbol

Absolute maximum ratings(Ta=25°C)

SYMBOL	PARAMETER	CONDITIONS	VALUE	UNIT
V _{CBO}	Collector-base voltage	BDW94	-45	V
		BDW94A	-60	
		BDW94B	-80	
		BDW94C	-100	
V _{CEO}	Collector-emitter voltage	BDW94	-45	V
		BDW94A	-60	
		BDW94B	-80	
		BDW94C	-100	
V _{EBO}	Emitter-base voltage	Open collector	-5	V
I _C	Collector current-DC		-12	A
I _{CM}	Collector current-Pulse		-15	A
I _B	Base current		-0.2	A
P _C	Collector power dissipation	T _C =25°C	80	W
T _j	Junction temperature		150	°C
T _{stg}	Storage temperature		-65~150	°C

Silicon PNP Power Transistors

BDW94/A/B/C

CHARACTERISTICS

T_j=25 °C unless otherwise specified

SYMBOL	PARAMETER	CONDITIONS	MIN	TYP.	MAX	UNIT	
V _{CEO(SUS)}	Collector-emitter sustaining voltage	BDW94	I _C =0.1A, I _B =0	-45			V
		BDW94A		-60			
		BDW94B		-80			
		BDW94C		-100			
V _{CEsat-1}	Collector-emitter saturation voltage	I _C =-5A, I _B =-20mA			-2.0	V	
V _{CEsat-2}	Collector-emitter saturation voltage	I _C =-10A, I _B =-0.1A			-3.0	V	
V _{BESat-1}	Base-emitter saturation voltage	I _C =-5A, I _B =-20mA			-2.5	V	
V _{BESat-2}	Base-emitter saturation voltage	I _C =-10A, I _B =-0.1A			-4.0	V	
I _{CBO}	Collector cut-off current	BDW94	V _{CB} =-45V, I _E =0			-0.1	mA
		BDW94A		V _{CB} =-60V, I _E =0			
		BDW94B		V _{CB} =-80V, I _E =0			
		BDW94C		V _{CB} =-100V, I _E =0			
I _{CEO}	Collector cut-off current	BDW94	V _{CE} =-45V, I _B =0			-1.0	mA
		BDW94A		V _{CE} =-60V, I _B =0			
		BDW94B		V _{CE} =-80V, I _B =0			
		BDW94C		V _{CE} =-100V, I _B =0			
I _{EBO}	Emitter cut-off current	V _{EB} =-5V; I _C =0			-2.0	mA	
h _{FE-1}	DC current gain	I _C =-3A; V _{CE} =-3V	1000				
h _{FE-2}	DC current gain	I _C =-5A; V _{CE} =-3V	750		20000		
h _{FE-3}	DC current gain	I _C =-10A; V _{CE} =-3V	100				
V _{F-1}	Forward diode voltage	I _F =-5A			-2.0	V	
V _{F-2}	Forward diode voltage	I _F =-10A			-4.0	V	

Silicon PNP Power Transistors

BDW94/A/B/C

PACKAGE OUTLINE

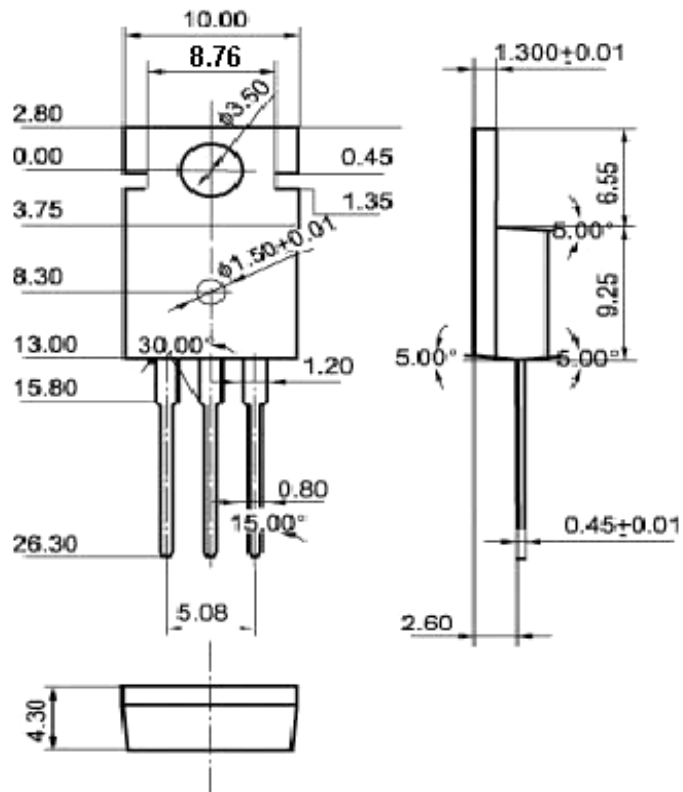

Fig.2 Outline dimensions