



LBN12004 SAW Filter Electrical Characteristic

Specifications

Parameter	Unit	Minimum	Typical	Maximum
Center Frequency	MHz	120.875	120	120.125
Insertion Loss	dB	-	27	29
1.5 dB Bandwidth	MHz	15.1	15.13	-
18 dB Bandwidth	MHz	-	15.86	15.9
25 dB Bandwidth	MHz	-	15.99	16.1
30 dB Bandwidth	MHz	-	16.07	16.5
40 dB Bandwidth	MHz	-	16.17	18.5
Ultimate Rejection	dB	40	48	-
Passband Variation	dB	-	0.7	1.5
Absolute Delay	usec	-	2.56	2.75
Substrate Material		YZ		
Ambient Temperature	°C	25		
Package Size		DIP3512 (35.2x12.7x5.2mm ³)		

Typical Performance

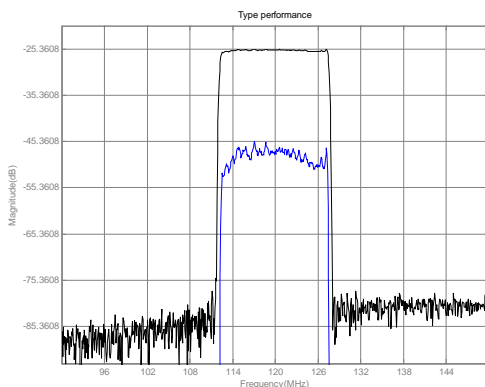

Package Outline

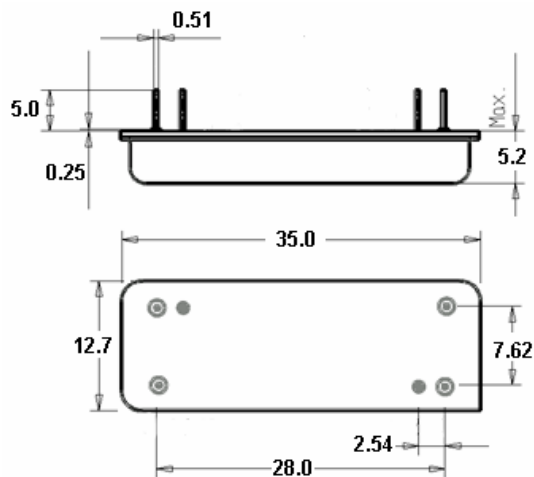

Matching Configuration

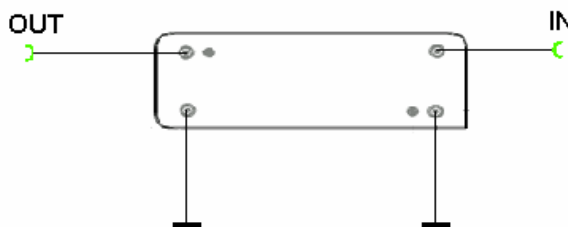

Source/Load Impedance=50 ohm

Notes - Component values may change depending on board layout.