

WCDMA / HSUPA Band II Tritium III PA Duplexer Module™

Functional Block Diagram

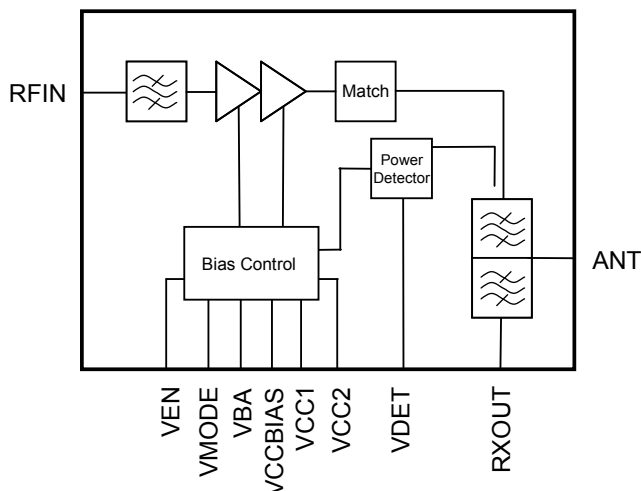

Product Description

The Tritium III PAD Module™ is an integrated 3V Linear Power Amplifier, Duplexer and Transmit Filter Module including a highly accurate Output Power Detector designed for mobile UMTS handset applications, supporting HSUPA operation with transmission data-rates up to 10Mb/s.

It features two output power modes, additional continuous bias in low power mode, low off and standby currents, and a separate pin for module enable. RF input and output matching is included within the module; therefore, minimal external circuitry is required. Tritium III™ gives excellent RF performance with low current consumption resulting in longer talk times in portable applications. The tiny 7x4x1.1 mm³ surface mount package is ideal for new generation slim, small and light phones.

Electrical Specifications

Parameter	Min	Typ	Max	Units
Frequency	1852.4		1907.6	MHz
Linear P _{OUT} (HSUPA) high power mode		25		dBm
Maximum current high power mode		525		mA
Linear P _{OUT} (HSUPA) low power mode		16		dBm
Idle current low power mode		15		mA
ACPR (HSUPA) 5 MHz		-45		dBc
ALPR (HSUPA) 10 MHz		-60		dBc
Ant-to-RX Insertion Loss		3		dB

Test Conditions: V_{CC1} = V_{CC2} = 3.4 V, T = 25°C

Advance Data Sheet: Subject to change without notice

For additional information and latest specifications, see our website: www.triquint.com

Revision B, January 31, 2008

Features

- Handset Tritium III PAD™ (PA-Duplexer) Module for UMTS Band II (PCS-band)
- Specified for HSUPA Modulation (Transmission Data-Rates up to 10Mb/s)
- Integrates Power Amplifier, Highly Accurate Output Power Detector, Transmit Filter and Duplexer
- No Regulated Voltage Required
- Separate 'Module Enable' Pin
- All RF Ports Matched to 50 Ω
- Low Current Consumption:
 - 2 Power Modes
 - Continuous Bias in Low Power Mode
 - Extremely Low Idle Current (15mA typ.) in Low Power Mode
- Compatible for Low Collector Voltage Operation with DC-DC-Converters

Applications

- 3G UMTS Handsets and Data-Cards

Package Style

- Compact 7 x 4 x 1.1 mm³ 16-Pin LGA Package

