

## Silicon PNP Power Transistors

2SA1094

## DESCRIPTION

- With MT-200 package
- Complement to type 2SC2564

## APPLICATIONS

- For power amplifier applications

## PINNING(see Fig.2)

PIN	DESCRIPTION
1	Base
2	Collector;connected to mounting base
3	Emitter

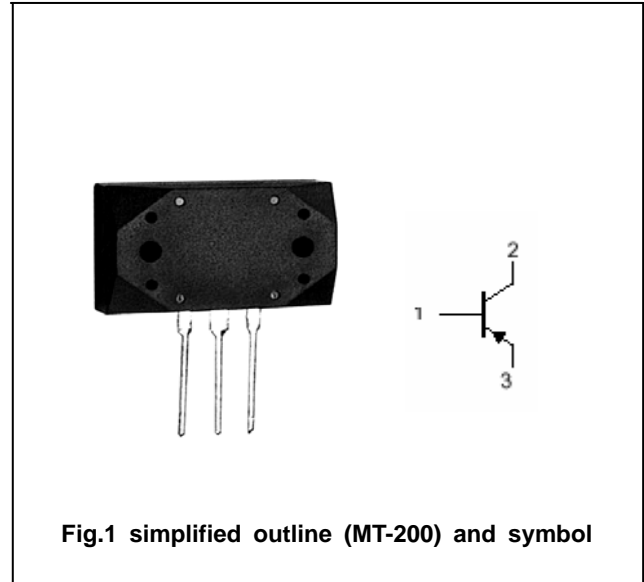
Absolute maximum ratings( $T_a=25^\circ\text{C}$ )

SYMBOL	PARAMETER	CONDITIONS	VALUE	UNIT
$V_{CBO}$	Collector-base voltage	Open emitter	-140	V
$V_{CEO}$	Collector-emitter voltage	Open base	-140	V
$V_{EBO}$	Emitter-base voltage	Open collector	-5	V
$I_C$	Collector current		-12	A
$I_B$	Base current		-1.2	A
$P_C$	Collector power dissipation	$T_C=25^\circ\text{C}$	120	W
$T_j$	Junction temperature		150	$^\circ\text{C}$
$T_{stg}$	Storage temperature		-55~150	$^\circ\text{C}$

## Silicon PNP Power Transistors

## 2SA1094

## CHARACTERISTICS

T<sub>j</sub>=25°C unless otherwise specified

SYMBOL	PARAMETER	CONDITIONS	MIN	TYP.	MAX	UNIT
V <sub>(BR)CEO</sub>	Collector-emitter breakdown voltage	I <sub>C</sub> =-0.1A ; I <sub>B</sub> =0	-140			V
V <sub>(BR)EBO</sub>	Emitter-base breakdown voltage	I <sub>E</sub> =-0.01A ; I <sub>C</sub> =0	-5			V
V <sub>CEsat</sub>	Collector-emitter saturation voltage	I <sub>C</sub> =-5A ; I <sub>B</sub> =-0.5A			-2.0	V
V <sub>BE</sub>	Base-emitter on voltage	I <sub>C</sub> =-5A ; V <sub>CE</sub> =-5V			-2.0	V
I <sub>CBO</sub>	Collector cut-off current	V <sub>CB</sub> =-140V ; I <sub>E</sub> =0			-50	μ A
I <sub>EBO</sub>	Emitter cut-off current	V <sub>EB</sub> =-5V ; I <sub>C</sub> =0			-50	μ A
h <sub>FE-1</sub>	DC current gain	I <sub>C</sub> =-1A ; V <sub>CE</sub> =-5V	55		240	
h <sub>FE-2</sub>	DC current gain	I <sub>C</sub> =-5A ; V <sub>CE</sub> =-5V	30			
C <sub>ob</sub>	Output capacitance	I <sub>E</sub> =0 ; V <sub>CB</sub> =-10V ; f=1MHz		220		pF
f <sub>T</sub>	Transition frequency	I <sub>C</sub> =-1A ; V <sub>CE</sub> =-10V		70		MHz

◆ h<sub>FE-1</sub> classifications

R	O	Y
55-110	80-160	120-240

PACKAGE OUTLINE

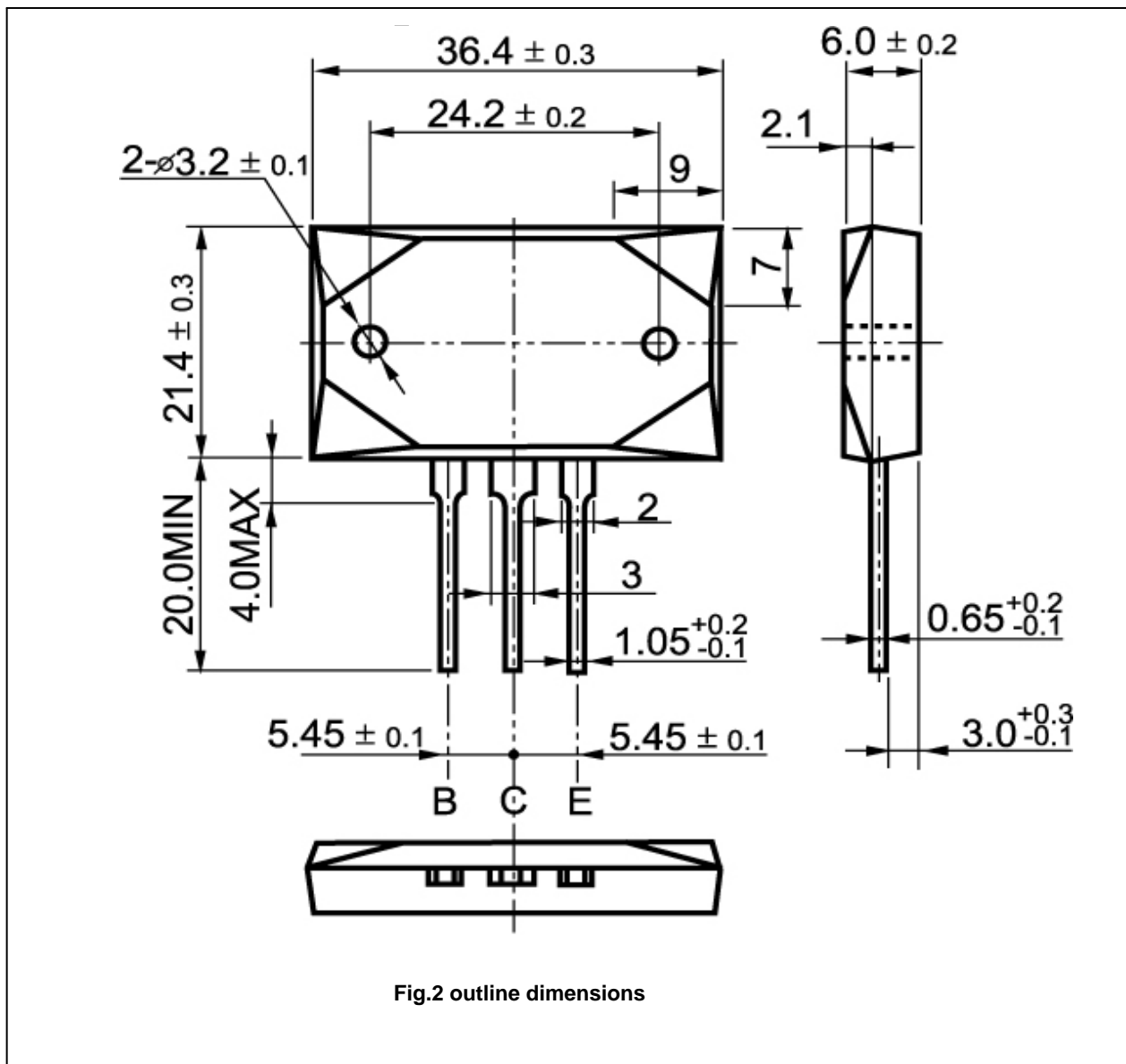

Fig.2 outline dimensions