

NOTES :

1. MATERIAL - PP8.
2. ALL DIMENSIONS ARE IN MILLIMETERS.
3. TOLERANCES - X.X=±0.25  
- X.XX=±0.13  
UNLESS OTHERWISE SPECIFIED.
4. ESD - SURFACE RESISTIVITY  
- 10<sup>5</sup> TO 10<sup>11</sup> OHMS/SQ.
5. FOR PACKAGE - PBGA
6. PART NO. : NH BG2727 2.0 0410 8  
(PLEASE INDICATE ON PURCHASE ORDER).
7. DATE CODE IS ON THE TRAY BOTTOM

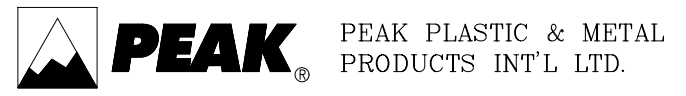

REV.NO.	ECN #	DESCRIPTION	DATE
6	P-01071	ADD MATERIAL ON TRAY CORNERS AND THICKENING THE RIBS AT CERTAIN PROTON OF THE TRAY FILL THE HOLES TO STRENGTH THE TRAY AT FOUR CORNERS OF THE TRAY	21 JUN 01
5	P-00987	ADD 4 RIBS AT THE FRAME	24 JUL 00
4	P-00944	CHANGE TEMPERATURE	27 APR 99
3	P-00821	CHANGE SURFACE RESISTIVITY	1 FEB 99
2	P-00681	CHANGE POSITION TOL	16 OCT 97

THIS DOCUMENT CONTAINS INFORMATION PROPRIETARY TO PEAK PLASTIC & METAL PRODUCTS INTERNATIONAL LIMITED. REPRODUCTION, DISCLOSURE OR USE OF THIS DOCUMENT IS EXPRESSLY PROHIBITED EXCEPT IF OTHERWISE AGREED UPON IN WRITING.

DRAWN BY :	BUSH	PAGE 1 OF 2
CHECKED BY :	WILDER	DATE : 21 JUN 01
APPROVED BY :	JONES	DATE : 21 JUN 01
APPROVED BY :	DAVY	DATE : 21 JUN 01
DO NOT SCALE DRAWING	CODE : CSA02793	

CUSTOMER :	PEAK
TITLE :	NH BG2727 2.0 0410 8
DWG NO.:	NH BG2727 2.0 0410 8
REV.	6

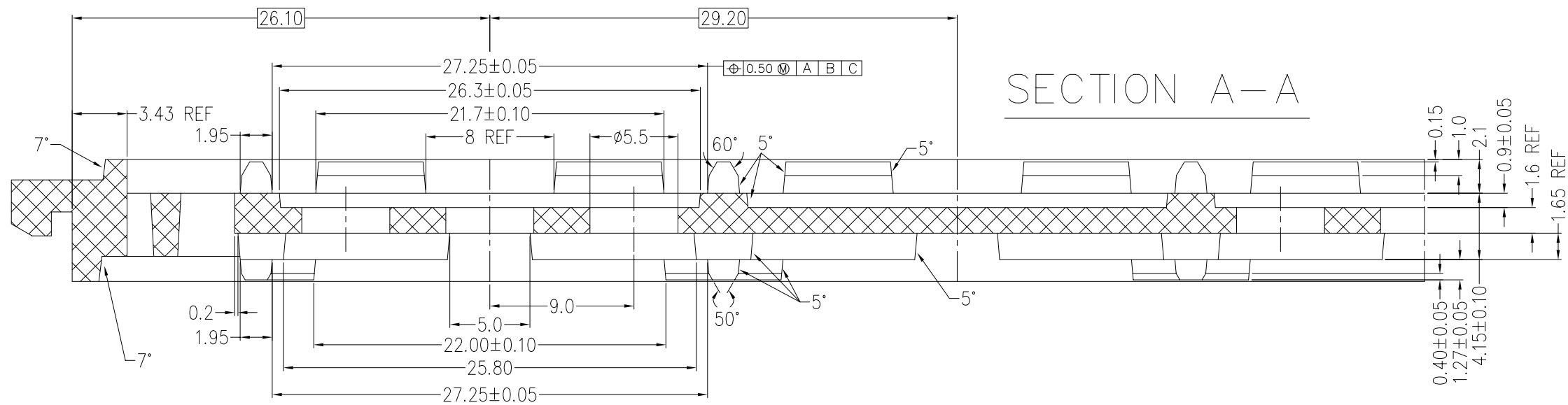

SECTION A-A

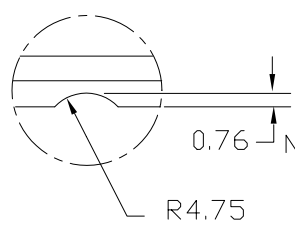

DETAIL C

NOTE: SCALLOP IS CENTERED ON SIDE OF TRAY

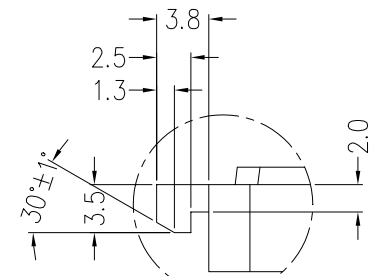

DETAIL D

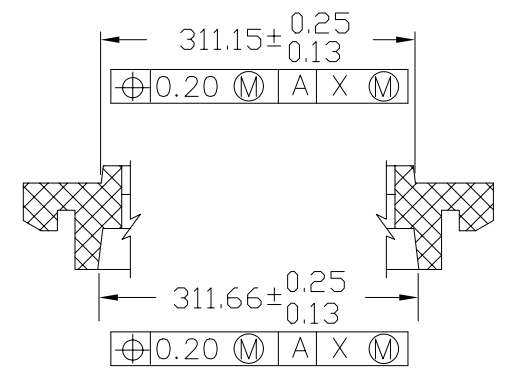

SECTION H-H

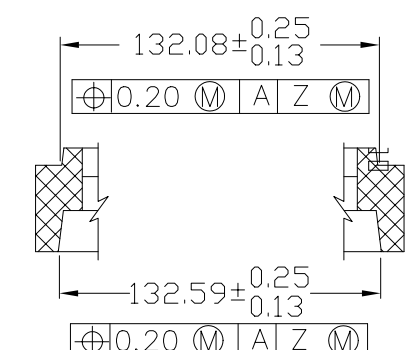

SECTION J-J

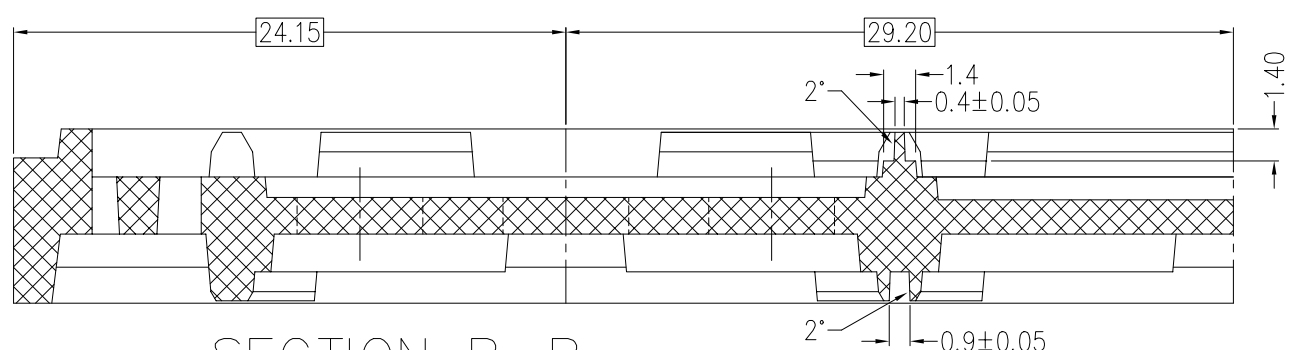

SECTION B-B



6	P-01071	ADD MATERIAL ON TRAY CORNERS AND THICKENING THE RIBS AT CERTAIN PROTON OF THE TRAY FILL THE HOLES TO STRENGTH THE TRAY AT FOUR CORNERS OF TH E TRAY	21 JUN 01
5	P-00987	ADD 4 RIBS AT THE FRAME	24 JUL 00
4	P-00944	CHANGE TEMPERATURE	27 APR 99
3	P-00821	CHANGE SURFACE RESISTIVITY	1 FEB 99
2	P-00681	CHANGE POSITION TOL	16 OCT 97
REV.NO.	ECN #	DESCRIPTION	DATE

THIS DOCUMENT CONTAINS INFORMATION PROPRIETARY TO PEAK PLASTIC & METAL PRODUCTS INTERNATIONAL LIMITED. REPRODUCTION, DISCLOSURE OR USE OF THIS DOCUMENT IS EXPRESSLY PROHIBITED EXCEPT IF OTHERWISE AGREED UPON IN WRITTING.

DRAWN BY :	BUSH	PAGE 2 OF 2
CHECKED BY :	WILDER	DATE : 21 JUN 01
APPROVED BY :	JONES	DATE : 21 JUN 01
APPROVED BY :	DAVY	DATE : 21 JUN 01
DO NOT SCALE DRAWING	CODE : CSA02793	

CUSTOMER :	PEAK
TITLE :	NH BG2727 2.0 0410 8
DWG NO.:	NH BG2727 2.0 0410 8
REV.	6