

VSC7716

1.25 Gbps Burst Mode Transimpedance Amplifier for GE-PON (EPON) Systems



FEATURES:

- ▶ Wide 27 dBm Dynamic Range
- ▶ Supports Input Power Greater than -3 dBm
- ▶ Accomodates Both PIN and Avalanche (APD) Photodetectors
- ▶ Designed for 4-pin or 5-pin TO-46 Packages

BENEFITS:

- ▶ Provides High Sensitivity Without Compromising Overload Performance
- ▶ High Input Overload Power Enable Operation in Diverse Network Environments
- ▶ Flexible Support for 10 km and 20 km Applications
- ▶ Easy Implementation in Standard Packaging

SPECIFICATIONS:

- ▶ 100 ns Typical Receiver Settling Time
- ▶ 80 mA Modulation Current DC-coupled to Laser
- ▶ 80 mW Typical Power Dissipation
- ▶ 3.3 V Power Supply

BLOCK DIAGRAM:

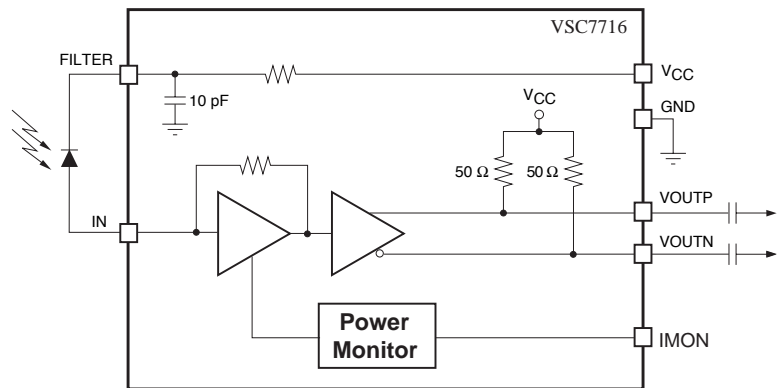

GENERAL DESCRIPTION:

The VSC7716 device is a transimpedance amplifier (TIA) for GE-PON ONU and OLT applications. The output settling time is sufficiently fast to meet GE-PON OLT receiver requirements but slow enough to pass GE-PON ONU traffic. The VSC7716 device is equipped with an optional photocurrent monitor pin to provide a means of monitoring continuous optical receive power for photodetector alignment and digital diagnostics. The device padout is optimized for standard 4-pin and 5-pin TO-46 packages and accommodates both PIN detector and Avalanche photodiode (APD) designs. A space-saving filter connection is provided for positive bias to the photodiode through a filter resistor to VCC. The VSC7716 device is available in bare die only.

Trademarks™

Vitesse, ASIC-Friendly, FibreTimer, TimeStream, Snoop Loop, Super FEC, FOCUSConnect, Meigs-II, Meigs-IIIe, Lansing, Campbell-I, Barrington, PaceMaker, HOVCAT48, HOVCAT48e, HOVCAT192, HOVCAT192e, Micro PHY, FOCUS32, FOCUS16, IQ2200, VersaCAT, GigaStream, HawX, SparX, StaX, VstaX, SimpliPHY, VeriPHY, ActiPHY, XFP PRO, SFP PRO, Smart-LINKOctalMAC, EQ Technology are trademarks in the United States and/or other jurisdictions of Vitesse Semiconductor Corporation. All other trademarks or registered trademarks mentioned herein are the property of their respective holders.

Copyright ©

Vitesse Semiconductor Corporation ("Vitesse") retains the right to make changes to its products or specifications to improve performance, reliability or manufacturability. All information in this document, including descriptions of features, functions, performance, technical specifications and availability, is subject to change without notice at any time. While the information furnished herein is held to be accurate and reliable, no responsibility will be assumed by Vitesse for its use. Furthermore, the information contained herein does not convey to the purchaser of microelectronic devices any license under the patent right of any manufacturer.

741 Calle Plano
Camarillo, CA 93012, USA
Tel: +1 805.388.3700
Fax: +1 805.987.5896
www.vitesse.com
sales@vitesse.com