

**SPS-4102WG / SPS-4102BWG**

**(RoHS Compliant)**

**3.3V / 1310 nm / 8.5 Gbps Digital Diagnostic LC SFP+ SINGLE-MODE TRANSCEIVER**

**FEATURES**

- | Up to 8.5 Gb/s Bi-directional Data Link
- | Compliant to SFP+ MSA
- | Compliance with Fibre Channel FC-PI-4 800-SM-LC-I
- | Compliant with 4x /2x Fibre Channel
- | **SFF-8472 Digital Diagnostic Function**
- | 1310 nm FP LD Transmitter
- | Link Distance: 0 to 1400 m at 8.5 Gb/s, 0 to 5000 m at 4.25 Gb/s, and 0 to 10,000 m at 2.125Gb/s
- | AC/AC Coupling according to MSA
- | Single +3.3 V Power Supply
- | RoHS 6/6 Compliant
- | 0 to 70°C Operating: SPS-4102WG
- | -10 to 85°C Operating: SPS-4102BWG
- | Class 1 Laser International Safety Standard IEC-60825 Compliant

**DESCRIPTION**

The SPS-4102WG series single mode transceiver is small form factor pluggable module for bi-directional serial optical data communications such as 8x/4x/2x Fibre Channel. It is with the SFP+ 20-pin connector to allow hot plug capability. Digital diagnostic functions are available via an I<sup>2</sup>C. This module is designed for single mode fiber and operates at a nominal wavelength of 1310 nm. The transmitter section uses a 1310 nm multiple quantum well laser and is a class 1 laser compliant according to International Safety Standard IEC-60825. The receiver section uses an integrated InGaAs detector preamplifier (IDP) mounted in an optical header and a limiting post-amplifier IC.

**LASER SAFETY**

This single mode transceiver is a Class 1 laser product. It complies with IEC-60825 and FDA 21 CFR 1040.10 and 1040.11. The transceiver must be operated within the specified temperature and voltage limits. The optical ports of the module shall be terminated with an optical connector or with a dust plug.

**APPLICATIONS**

- | Multi-rate 8x / 4x / 2x Fibre Channel

**ORDER INFORMATION**

P/No.	Bit Rate (Gb/s)	FC-PI	Distance (m)	Wavelength (nm)	Package	Temp. (°C)	RoHS Compliant
SPS-4102WG	8 / 4 / 2	FC-PI-4	1400*	1310	SFP+ with DMI	0 to 70	Yes
SPS-4102BWG	8 / 4 / 2	FC-PI-4	1400*	1310	SFP+ with DMI	-10 to 85	Yes

\*: 0 to 1400 m at 8.5 Gb/s, 0 to 5000 m at 4.25 Gb/s, and 10 km at FC 1x/2x.

Absolute Maximum Ratings					
Parameter	Symbol	Min	Max	Units	Notes
Storage Temperature	Tstg	-40	85	°C	
Operating Case Temperature	Topr	0	70	°C	SPS-4102WG
		-10	85		SPS-4102BWG
Power Supply Voltage	Vcc	-0.5	3.6	V	

Recommended Operating Conditions					
Parameter	Symbol	Min	Typ	Max	Units / Notes
Power Supply Voltage	Vcc	3.13	3.3	3.47	V
Operating Case Temperature	Topr	0		70	°C / SPS-4102WG
		-10		85	°C / SPS-4102BWG
Power Supply Current	I <sub>CC(TX+RX)</sub>		250	300	mA
Data Rate		1	8.5		Gb/s

\*\*\*\*\*

Transmitter Optical Specifications (0°C < Topr < 70°C, 3.13V < Vcc < 3.47V)						
Parameter	Symbol	Min	Typ	Max	Units	Notes
Average Launch Power	P <sub>O, Avg</sub>	-8		0	dBm	1
Optical Modulation Amplitude	P <sub>O, OMA</sub>	0.29			mW	
Output Center Wavelength	λ <sub>c</sub>	1270	1310	1350	nm	
Output Spectrum Width	σ <sub>λ</sub>		2		nm	RMS (σ)
Optical Rise / Fall Time (8.5Gb/s)	t <sub>r</sub> / t <sub>f</sub>			50	ps	20 % to 80% ,unfiltered
Relative Intensity Noise	RIN			-128	dB/Hz	
Average Launch Power of OFF Transmitter				-30	dBm	

1. Output power is power coupled into a 9/125 μm single-mode fiber.

Receiver Optical Specifications (0°C < Topr < 70°C, 3.13V < Vcc < 3.47V)						
Parameter	Symbol	Min	Typ	Max	Units	Notes
Unstressed Sensitivity at 8.5 Gb/s	Sens			0.042	mW <sub>p-p</sub>	2, OMA
				-15	dBm	3, Average Power
Stress Sensitivity at 8.5 Gb/s	Sens		---	0.066	mW <sub>p-p</sub>	2, OMA
Receiver Overload	P <sub>MAX</sub>	0.5	---		dBm	
LOS -- Deasserted	LOS <sub>D</sub>	---	---	-15	dBm	Transition: low to high
LOS -- Asserted	LOS <sub>A</sub>	-25	---	---	dBm	Transition: high to low
Wavelength of Operation	λ <sub>c</sub>	1260		1565	nm	
Optical Return Loss	ORL			-12	dB	

2. Measured with worst ER; BER < 10<sup>-12</sup> and PRBS 2<sup>7</sup>-1.

3. Represents sensitivity based on OMA spec, as corrected to incoming Extinction Ratio of 7 dB. For example, an OMA of 0.042 mW is approximately equal to an average power of -15 dBm, average with an Extinction ratio of 7 dB.

Electrical Characteristics						
Parameter	Symbol	Min	Typ	Max	Units	Notes
<b>High-Speed Signal (CML) Interface Specification</b>						
Input Data Rate		1	8.5		Gb/s	
Differential Input Impedance	R <sub>in</sub>		100		Ω	
Differential Data Input Amplitude		300		1200	mV <sub>pp</sub>	Internally AC coupled
Output Data Rate		1	8.5		Gb/s	
Differential Output Impedance	R <sub>out</sub>		100		Ω	
Differential Data Output Amplitude		350	600	700	mV <sub>pp</sub>	Internally AC coupled
<b>Low-Speed Signal (LVTTTL) Interface Specification</b>						
Input High Voltage		2.0		V <sub>cc</sub> +0.3	V	
Input Low Voltage		GND		0.8	V	
Output High Voltage		2.4		V <sub>cc</sub>	V	
Output Low Voltage		GND		0.5	V	

CONNECTION DIAGRAM

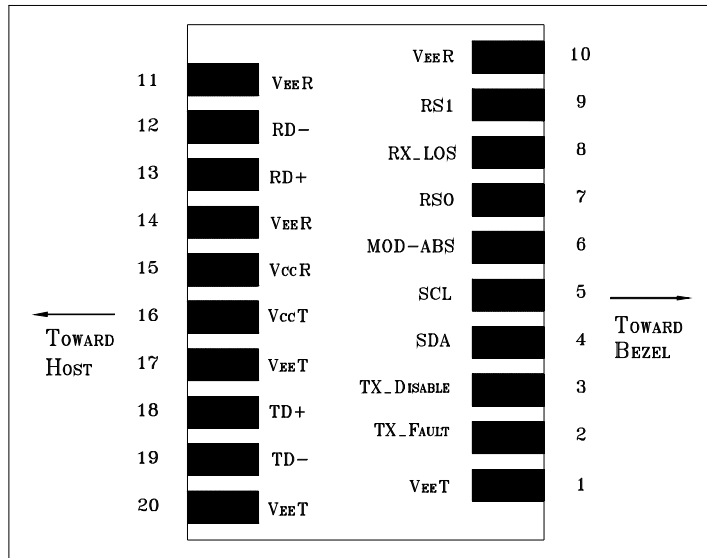

PIN	Signal Name	Description	PIN	Signal Name	Description
1	V <sub>EE</sub> T	Transmitter Signal Ground	11	V <sub>EE</sub> R	Receiver Signal Ground
2	TX_Fault	Transmitter Fault Indication. Logic “1” Output = Laser Fault. Logic “0” Output = Normal Operation	12	RD-	Inverse Receiver Data Out
3	TX_Disable	Logic “1” Input (or no connection) = Laser off, Logic “0” = Laser on.	13	RD+	Receiver Data Out
4	SDA	Modulation Definition 2 – Two wires serial ID Interface	14	V <sub>EE</sub> R	Receiver Signal Ground
5	SDL	Modulation Definition 1 – Two wires serial ID Interface	15	V <sub>CC</sub> R	Receiver Power – 3.3V±5%
6	MOD-ABS	Modulation Definition 0 – Ground in Module	16	V <sub>CC</sub> T	Transmitter Power – 3.3V±5%
7	RS0	RX Rate Select (LVTTTL). This pin has an internal 30k pulldown to ground. A signal on this pin will not affect module performance.	17	V <sub>EE</sub> T	Transmitter Signal Ground
8	RX_LOS	Loss of Signal Out (OC).	18	TD+	Transmitter Data In
9	RS1	TX Rate Select (LVTTTL). This pin has an internal 30k pulldown to ground. A signal on this pin will not affect module performance.	19	TD-	Inverse Transmitter Data In
10	V <sub>EE</sub> R	Receiver Signal Ground	20	V <sub>EE</sub> T	Transmitter Signal Ground

### Module Definition

Module Definition	PIN 4	PIN 5	PIN 6	Interpretation by Host
4	SDA	SCL	MOD-ABS	Serial module definition protocol

Module Definition 4 specifies a serial definition protocol. For this definition, upon power up, SDA and SDL appear as no connector (NC) and MOD-ABS is TTL LOW. When the host system detects this condition, it activates the serial protocol. The protocol uses the 2-wire serial CMOS E<sup>2</sup>PROM protocol of the ATMEL AT24C01A/02/04 family of components.

## RECOMMENDED CIRCUIT SCHEMATIC

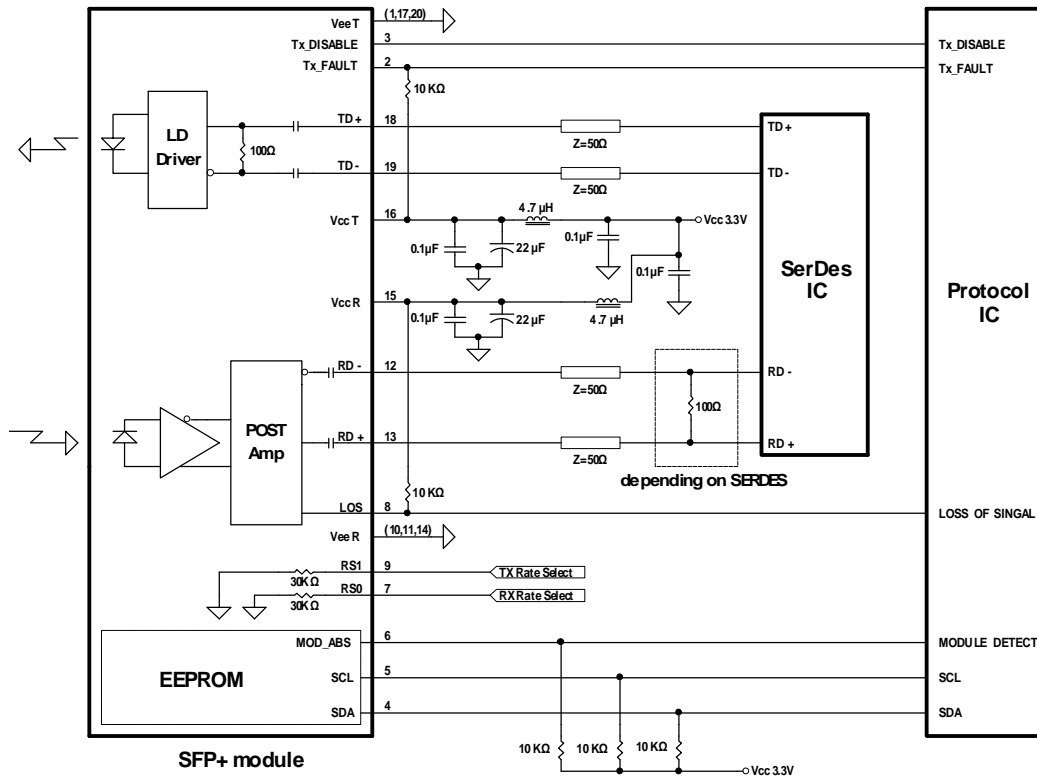

## PACKAGE DIAGRAM

Units in mm

Top View

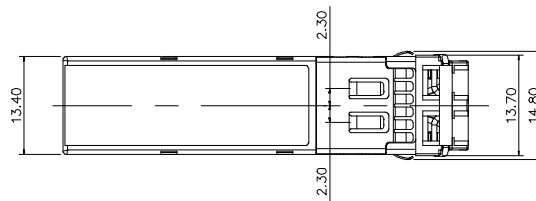

Front View

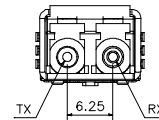
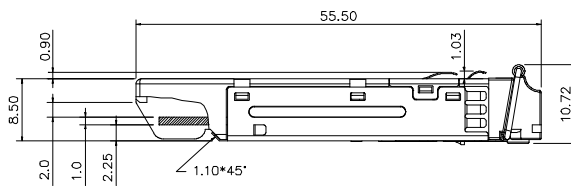

Side View

Bottom View

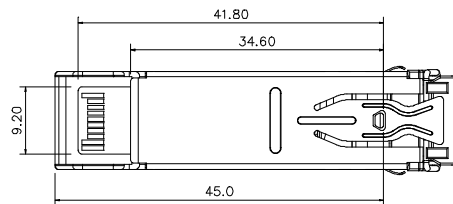

\*\*\*\*\*  
 EEPROM Series ID Memory Contents (Address A0h)  
 \*\*\*\*\*

Addr.	Hex	ASCII	Note	Addr.	Hex	ASCII	Note	Addr.	Hex	ASCII	Note	Addr.	Hex	ASCII	Note
0	03		SFP	32	20			64	00		Txdis, Txfault,	96	00		Vendor specific EEPROM
1	04			33	20			65	1A		LOS enable	97	00		
2	07		LC	34	20			66	00		Up bit rate	98	00		
3	00			35	20			67	00		Low bit rate	99	00		
4	00			36	00		NA	68			Serial	100	00		
5	00			37	00		Vendor IEEE OUI	69			number: each piece with different serial number	101	00		
6	00			38	0E			70				102	00		
7	22		Intermediate(I),LC	39	FA		71			103		00			
8	00			40	53	S	Part Number	72				104	00		
9	01		Single Mode (SM)	41	50	P		73				105	00		
10	54		8/4/2 GBd	42	53	S		74				106	00		
11	01		8B/10B	43	2D	-		75			107	00			
12	55		8.5Gbps	44	34	4		76			108	00			
13	00			45	31	1		77			109	00			
14	01		1.4km	46	30	0		78			110	00			
15	0E		1400m	47	32	2		79			111	00			
16	00			48	57	W		80			112	00			
17	00			49	47	G		81			113	00			
18	00			50	20		82			114	00				
19	00			51	20		83			115	00				
20	4F	O	Vendor name	52	20		Revision, depended on version	84			Date Code	116	00		
21	50	P		53	20			85				117	00		
22	54	T		54	20			86				118	00		
23	4F	O		55	20			87				119	00		
24	57	W		56	30	0		88				120	00		
25	41	A		57	30	0		89				121	00		
26	59	Y		58	30	0		90			122	00			
27	20		59	30	0	91			123	00					
28	20			60	05		1310 nm	92	68		Monitoring	124	00		
29	20			61	1E			93	F0		Soft Control	125	00		
30	20			62	00		Reserved	94	03		SFF-8472V10	126	00		
31	20			63			Checksum 0-62	95			Checksum 64-94	127	00		

\*\*\*\*\*  
**EEPROM Series ID Memory Contents (Address A2h)**  
 \*\*\*\*\*

Addr.	Hex	Note	Addr.	Hex	Note	Addr.	Hex	Note	Addr.	Hex	Note
0	5A	Temp. High Alarm (90°C)	32	37	Rx Power High Alarm (1413μW)	64	00	For External Cal.	96		Real Time Temp. MSB
1	00		33	2D		65	00	For External Cal.	97		Real Time Temp. LSB
2	FB	Temp. Low Alarm(-5°C)	34	01	Rx Power Low Alarm (27μW)	66	00	For External Cal.	98		Real Time Vcc MSB
3	00		35	09		67	00	For External Cal.	99		Real Time Vcc LSB
4	55	Temp. High Warming(85°C)	36	2B	Rx Power High Warming (1122μW)	68	00	For External Cal.	100		Real Time Tx Bias MSB
5	00		37	D4		69	00	For External Cal.	101		Real Time Tx Bias LSB
6	00	Temp. Low Warming (0°C)	38	01	Rx Power Low Warming(42μW)	70	00	For External Cal.	102		Real Time Tx Pwr MSB
7	00		39	A4		71	00	For External Cal.	103		Real Time Tx Pwr LSB
8	8C	Voltage High Alarm (3.6V)	40	00	Reserved	72	00	For External Cal.	104		Real Time Rx Pwr MSB
9	A0		41	00	Reserved	73	00	For External Cal.	105		Real Time Rx Pwr LSB
10	75	Voltage Low Alarm(3.0V)	42	00	Reserved	74	00	For External Cal.	106		Reserved
11	30		43	00	Reserved	75	00	For External Cal.	107		Reserved
12	88	Voltage High Warming(3.5V)	44	00	Reserved	76	00	For External Cal.	108		Reserved
13	B8		45	00	Reserved	77	00	For External Cal.	109		Reserved
14	79	voltage Low Warming (3.1V)	46	00	Reserved	78	00	For External Cal.	110		Tx Dis, Tx Fault, Rx Los
15	18		47	00	Reserved	79	00	For External Cal.	111		Reserved
16	AF	Tx Bias High Alarm(90mA)	48	00	Reserved	80	00	For External Cal.	112		Alarm Flag
17	C8		49	00	Reserved	81	00	For External Cal.	113		Alarm Flag/Reserved
18	03	Tx BiasLow Alarm(2mA)	50	00	Reserved	82	00	For External Cal.	114		Reserved
19	E8		51	00	Reserved	83	00	For External Cal.	115		Reserved
20	88	Tx Bias High Warming(70mA)	52	00	Reserved	84	00	For External Cal.	116		Warming Flag
21	B8		53	00	Reserved	85	00	For External Cal.	117		Warming Flag/Reserved
22	07	Tx Bias Low Warming(4mA)	54	00	Reserved	86	00	For External Cal.	118		Reserved
23	D0		55	00	Reserved	87	00	For External Cal.	119		Reserved
24	31	Tx Power High Alarm (1259μW))	56	00	For External Cal.	88	00	For External Cal.	120		Vendor Specific
25	2D		57	00	For External Cal.	89	00	For External Cal.	121		
26	04	Tx Power Low Alarm(126μW)	58	00	For External Cal.	90	00	For External Cal.	122		
27	EB		59	00	For External Cal.	91	00	For External Cal.	123		
28	27	Tx Power High Warming(1000μW)	60	00	For External Cal.	92	00	For External Cal.	124		
29	10		61	00	For External Cal.	93	00	For External Cal.	125		
30	06	Tx Power Low Warming (159μW)	62	00	For External Cal.	94	00	For External Cal.	126		
31	31		63	00	For External Cal.	95		Check Sum	127		

Note: Address 128 – 247: customer R/W eeprom. Address 248 – 255: Vendor Specific.

**Note:** Specifications subject to change without notice.