TRM-5101G / TRM-5101TG / TRM-5101AG / TRM-5101ATG

3.3V / 1310 nm / 622 Mbps **RoHS Compliant Optical Multi-Mode Transceiver**

FEATURES

- | Duplex SC Multimode Transceiver : TRM-5101G
- | Duplex ST Multimode Transceiver :TRM-5101TG
- | 1310 nm Transmitter
- | 0 to 1000 m Transmission
- | Industry Standard 1 x 9 Footprint
- | Single +3.3 V Power Supply
- | PECL Signal Detection Output
- | **RoHS Compliant**
- | 0 to 70°C Operating : TRM-5101G
- | -40 to 85°C Operating : TRM-5101AG
- | Wave Solderable and Aqueous Washable
- | Class 1 Laser International Safety Standard IEC 60825 Compliant

DESCRIPTION

The TRM-5101G series multi-mode transceivers are low power, high performance module for bi-directional serial optical data communications such as ATM 622 Mb/s, Fast Ethernet and Fibre Channel. This module is designed for multi-mode fiber and operates at a nominal wavelength of 1310 nm. The transmitter section uses a multiple quantum well laser and is a class 1 laser compliant according to International Safety Standard IEC 60825. The receiver section uses an integrated InGaAs detector preamplifier (IDP) mounted in an optical header and a limiting post-amplifier IC. A PECL logic interface simplifies interface to external circuitry.

APPLICATIONS

- | ATM 622 Mbps Links
- | SONET/SDH Equipment Interconnect
- | Fast Ethernet 100 Mb/s Links

LASER SAFETY

This multi-mode transceiver is a Class 1 laser product. It complies with IEC 60825 and FDA 21 CFR 1040.10 and 1040.11. The transceiver must be operated within the specified temperature and voltage limits. The optical ports of the module shall be terminated with an optical connector or with a dust plug.

ORDER INFORMATION

P/No.	Bit Rate (Mb/s)	Distance (m)	Wavelength (nm)	Voltage (V)	Connector	Temp. (°C)	TX Power (dBm)	RX Sens. (dBm)	RoHS Compliant
TRM-5101G	622	0 to 1000	1310	3.3	1X9 SC/ST	0 to 70	-12 to -19	-26	Y
TRM-5101AG	622	0 to 1000	1310	3.3	1X9 SC/ST	-40 to 85	-12 to -19	-26	Y

Absolute Maximum Ratings					
Parameter	Symbol	Min	Max	Units	Notes
Storage Temperature	Tstg	-40	85	°C	
Operating Temperature	Topr	0	70	°C	TRM-5101G
		-40	85		TRM-5101AG
Soldering Temperature	---		250	°C	10 seconds on leads only
Power Supply Voltage	Vcc	0	4.5	V	
Input Voltage	---	GND	Vcc	V	
Output Current	Iout	0	30	mA	

Recommended Operating Conditions					
Parameter	Symbol	Min	Typ	Max	Units
Power Supply Voltage	Vcc	3.13	3.3	3.47	V
Operating Temperature	Topr	0		70	°C / TRM-5101G
		-40		85	°C / TRM-5101AG
Data Rate		100	622		Mb/s

Transmitter Specifications (0°C < Topr < 70°C, 3.13V < Vcc < 3.47V)						
Parameter	Symbol	Min	Typ	Max	Units	Notes
Optical						
Optical Transmit Power	Po	-19	---	-12	dBm	1
Output Center Wavelength	λ	1260	1310	1360	nm	
Output Spectrum Width	$\Delta\lambda$	---	---	10	nm	RMS (σ)
Extinction Ratio	ER	8.2	---	---	dB	
Output Eye	Compliant with Bellcore TR-NWT-000253 and ITU recommendation G.957					
Optical Rise Time	t _r			1.2	ns	10% to 90% Values
Optical Fall Time	t _f			1.2	ns	10% to 90% Values
Relative Intensity Noise	RIN			-116	dB/Hz	
Total Jitter	TJ			0.55	ns	2
Electrical						
Power Supply Current	I _{cc}			140	mA	3
Data Input Current – Low	I _{IL}	-350			μ A	
Data Input Current – High	I _{IH}			350	μ A	
Differential Input Voltage	V _{IH} - V _{IL}	300			mV	
Data Input Voltage – Low	V _{IL} - V _{CC}	-2.0		-1.58	V	4
Data Input Voltage -- High	V _{IH} - V _{CC}	-1.1		-0.74	V	4

- Notes: 1. Output power is power coupled into a 62.5/125 μ m multi-mode fiber.
 2. Measured with a 2²³-1 PRBS with 72 ones and 72 zeros.
 3. Maximum current is specified at Vcc = Maximum @ maximum temperature.
 4. These inputs are compatible with 10K, 10KH and 100K ECL and PECL inputs.

Receiver Specifications (0°C < Topr < 70°C, 3.13 V < Vcc < 3.47V)						
Parameter	Symbol	Min	Typ	Max	Units	Notes
Optical						
Sensitivity	---	---	-28	-26	dBm	1
Maximum Input Power	P _{in}	-8	---	---	dBm	
Signal Detect -- Asserted	P _a	---	---	-26	dBm	Transition: low to high
Signal Detect -- Deasserted	P _d	-40	---	---	dBm	Transition: high to low
Signal detect -- Hysteresis		1.0	---	4.0	dB	
Wavelength of Operation		1100	---	1600	nm	
Electrical						
Power Supply Current	I _{cc}			100	mA	2
Data Output Voltage – Low	V _{OL} - V _{CC}	-2.0		-1.58	V	3
Data Output Voltage – High	V _{OH} - V _{CC}	-1.1		-0.74	V	3
Signal Detect Output Voltage -- Low	V _{OL} - V _{CC}	-2.0		-1.58	V	
Signal Detect Output Voltage -- High	V _{OH} - V _{CC}	-1.1		-0.74	V	

- Notes: 1. Minimum sensitivity and saturation levels at BER=1E-10 for a 2²³-1 PRBS.
 2. The current excludes the output load current.
 3. These outputs are compatible with 10K, 10KH and 100K ECL and LVPECL outputs.

CONNECTION DIAGRAM

Receiver Signal Ground	1 (Rx GND)	○
Receiver Data Out	2 (RD+)	N/C
Receiver Data Out Bar	3 (RD-)	
Signal Detect	4 (SD)	
Receiver Power Supply	5 (Rx Vcc)	TOP VIEW
Transmitter Power Supply	6 (Tx Vcc)	
Transmitter Data In Bar	7 (TD-)	
Transmitter Data In	8 (TD+)	N/C
Transmitter Signal Ground	9 (Tx GND)	○

PIN	Symbol	Notes
1	Rx GND	Directly connect this pin to the receiver ground plane
2	RD+	See recommended circuit schematic
3	RD-	See recommended circuit schematic
4	SD	Active high on this indicates a received optical signal
5	Rx Vcc	+3.3V dc power for the receiver section
6	Tx Vcc	+3.3V dc power for the transmitter section
7	TD-	See recommended circuit schematic
8	TD+	See recommended circuit schematic
9	Tx GND	Directly connect this plan to the transmitter ground plane

RECOMMENDED CIRCUIT SCHEMATIC

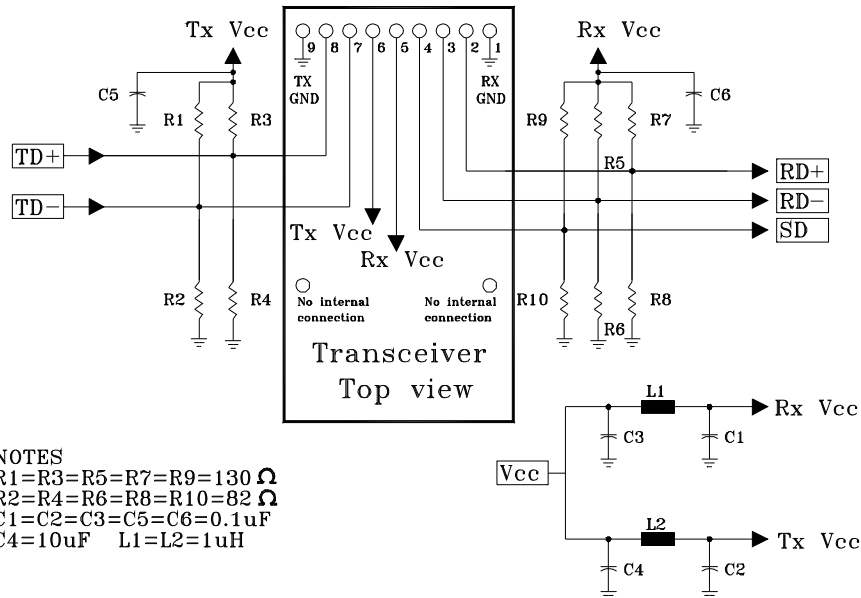

The split-load terminations for ECL signals need to be located at the input of devices receiving those ECL signals. The power supply filtering is required for good EMI performance. Use short tracks from the inductor L1/L2 to the module Rx Vcc and Tx Vcc. A GND plane under the module is required for good EMI and sensitivity performance.

PACKAGE DIAGRAM

Units in mm

1) SC Duplex

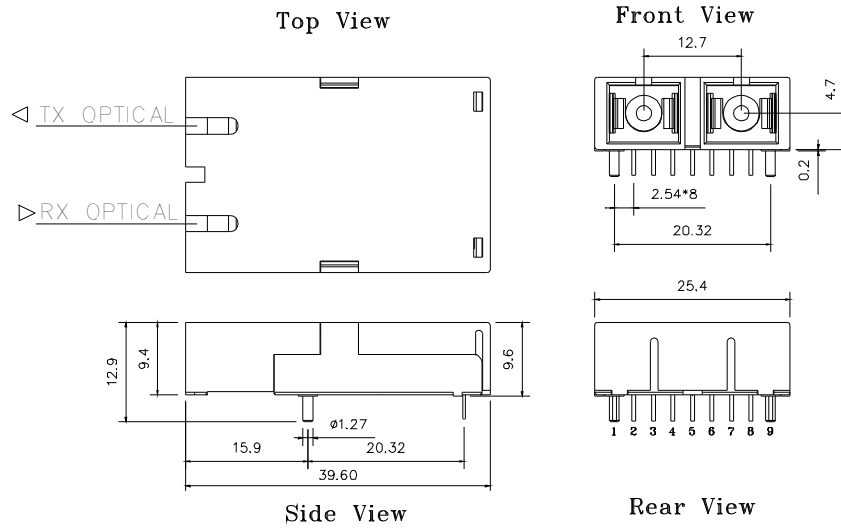

TRM-5101G / TRM-5101AG

2) SC Duplex with metal shielding

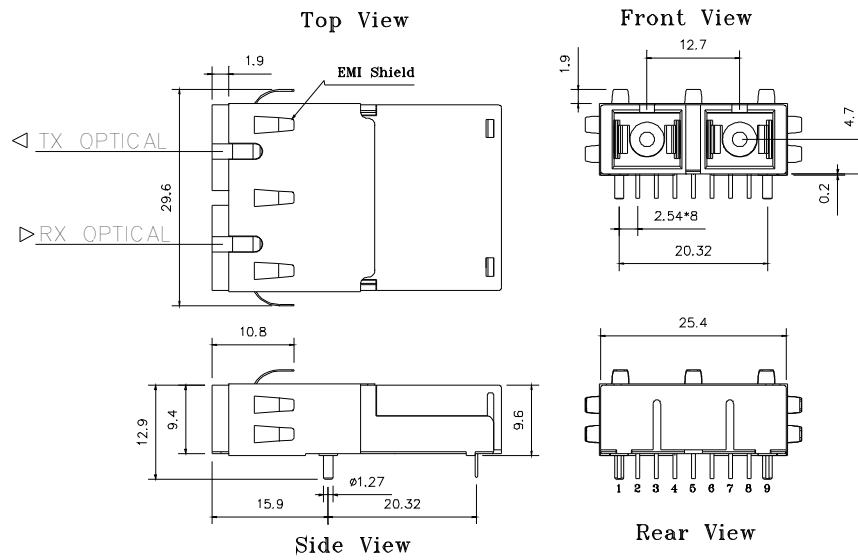

TRM-5101-EMG / TRM-5101A-EMG

3) Duplex ST

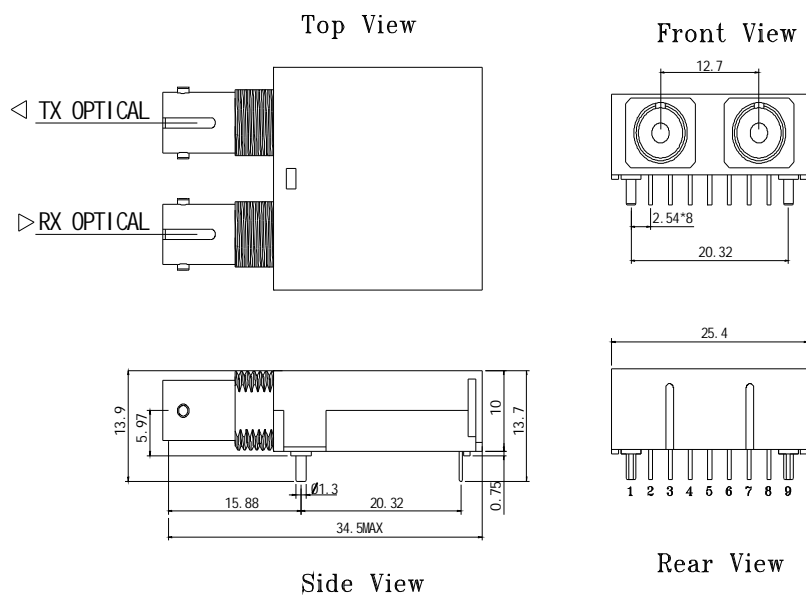

TRM-5101TG / TRM-5101ATG

Note: Specifications subject to change without notice.