

## DLBM-CH120

### Bluetooth™ Module Class 2

**A Class 2 Bluetooth™ module suitable for cellular phone, smart phone applications.**

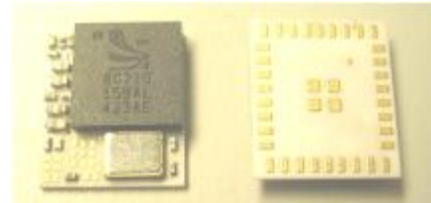

## 1.FEATURES:

- | **Support DUN, SPP, AG & FAX profiles.**
- | **Minimal software effort to own Bluetooth functions.**
- | **Almost no resource required from host CPU.**
- | **Reducing the size and thickness greatly by using high-density packaging technology.**
- | **Compliant to various interfaces: UART, USB, PCM ...etc.**
- | **Wide operating temperature range: -30~+80°C.**

## 2.Device diagram

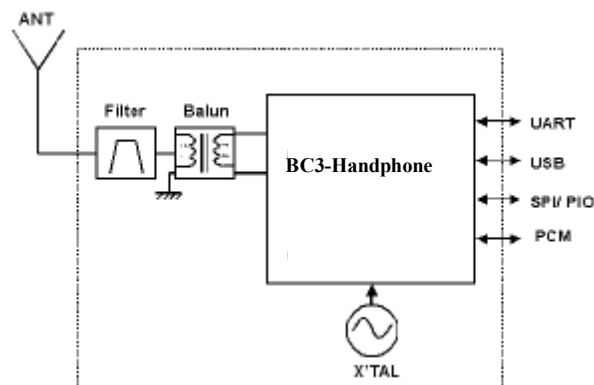

Figure 1. DLBM-CH120 Block Diagram



Preliminary

## DLBM-CH120

### 3. General Specification

Bluetooth™ Specification	Version 1.1
Frequency	2402~2480MHz
Modulation	FHSS/GFSK
Transmission rate	721kbps
Receive sensitivity	-79 dBm
Maximum output power	+4dBm(Class 2)
Operating Voltage	2.7~3.6V
Operating temperature	-30~+80℃
Antenna Impedance	50 ohm
Package size	9.1*7.9*1.6mm
Operating range	< 10 meters
Current consumption (TX)	< 35mA
Current consumption (Standby)	< 2mA

### 4. Rating

	Min	Max	Unit
Storage Temperature	-40	+85	℃
VDD_1.8V	-0.4	+1.9	V
VDD_IO	-0.4	+3.6	V
VREG_IN	-0.4	+3.6	V

Data Sheet

April 20, 2005

Proprietary Information and Specifications are Subject to Change

## 5.Interface

Interface	Description
Antenna	External Antenna 50 ohm
UART Interface	TX,RX,RTS,CTS(9600bps~1.5Mbps)
SPI Interface	Synchronous Serial Interface for firmware download
PIO Interface	9 terminals

## 6.Power Supply Diagram

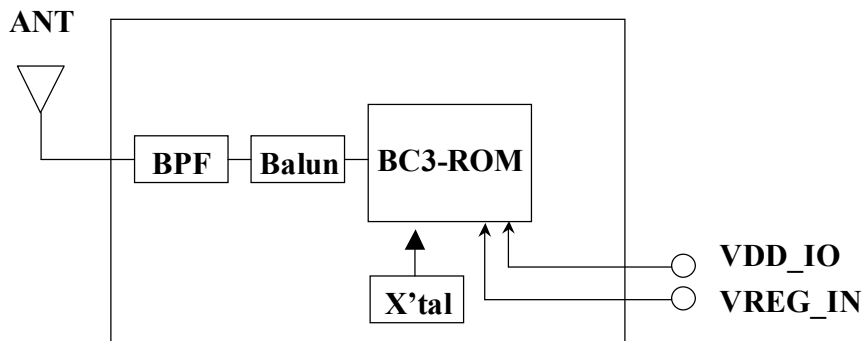

Figure 2. Power Supply Diagram

Terminal	VDD=3.0V	VDD=1.8V
VDD_1.8V	NC	1.7 to 1.9V
VDD_IO	2.7 to 3.6V	2.7 to 3.6V
VREG_IN	2.7 to 3.6V	NC



Preliminary

## DLBM-CH120

### 7. RF Characteristics

Operating Condition: +25°C, VDD=2.7V

RF Characteristics	Min.	Typ.	Max.	Unit
1. Frequency Range	2400 ~ 2483.5			MHz
2. Output Power		0	4	dBm
3. Sensitivity at 0.1% BER				
1) 2402MHz		-82		dBm
2) 2441MHz		-82		dBm
3) 2480MHz		-82		dBm
4. Maximum Input Level (BER ≤ 0.1%)		3		dBm
5. Adjacent channel selectivity				
1) C/I F=F <sub>0</sub> + 1MHz		-4	0	dB
2) C/I F=F <sub>0</sub> - 1MHz		-4	0	dB
3) C/I F=F <sub>0</sub> + 2MHz		-35	-30	dB
4) C/I F=F <sub>0</sub> - 2MHz		-21	-20	dB
5) C/I F ≥ F <sub>0</sub> + 3MHz		-45		dB
6) C/I F ≤ F <sub>0</sub> - 5MHz		-45		dB
7) C/I F=F <sub>image</sub>		-18	-9	dB
6. Adjacent channel transmit power				
1) F=F <sub>0</sub> ± 2MHz		-35		dBc
2) F=F <sub>0</sub> ± 3MHz		-55		dBc
7. Modulation Characteristics				
1) Modulation Δf <sub>1avg</sub>		165		kHz
2) Modulation Δf <sub>2max</sub>		155	-	kHz
8. Initial Carrier Frequency Tolerance				
1) 2402MHz	-75	-3	75	kHz
2) 2441MHz	-75	-7	75	kHz
3) 2480MHz	-75	-14	75	kHz



Preliminary

## DLBM-CH120

<b>9. Carrier Frequency Drift</b>				
1) 1 slot		9		kHz
2) 5slot		10		kHz
4) Drift rate		8		KHz/50us
<b>10. 20dB Bandwidth for modulated carrier</b>				
1) 2402MHz		879		KHz
2) 2441MHz		816		KHz
3) 2480MHz		819		KHz
<b>11.C/I co - channel</b>		9		dB

## 8.Application circuit

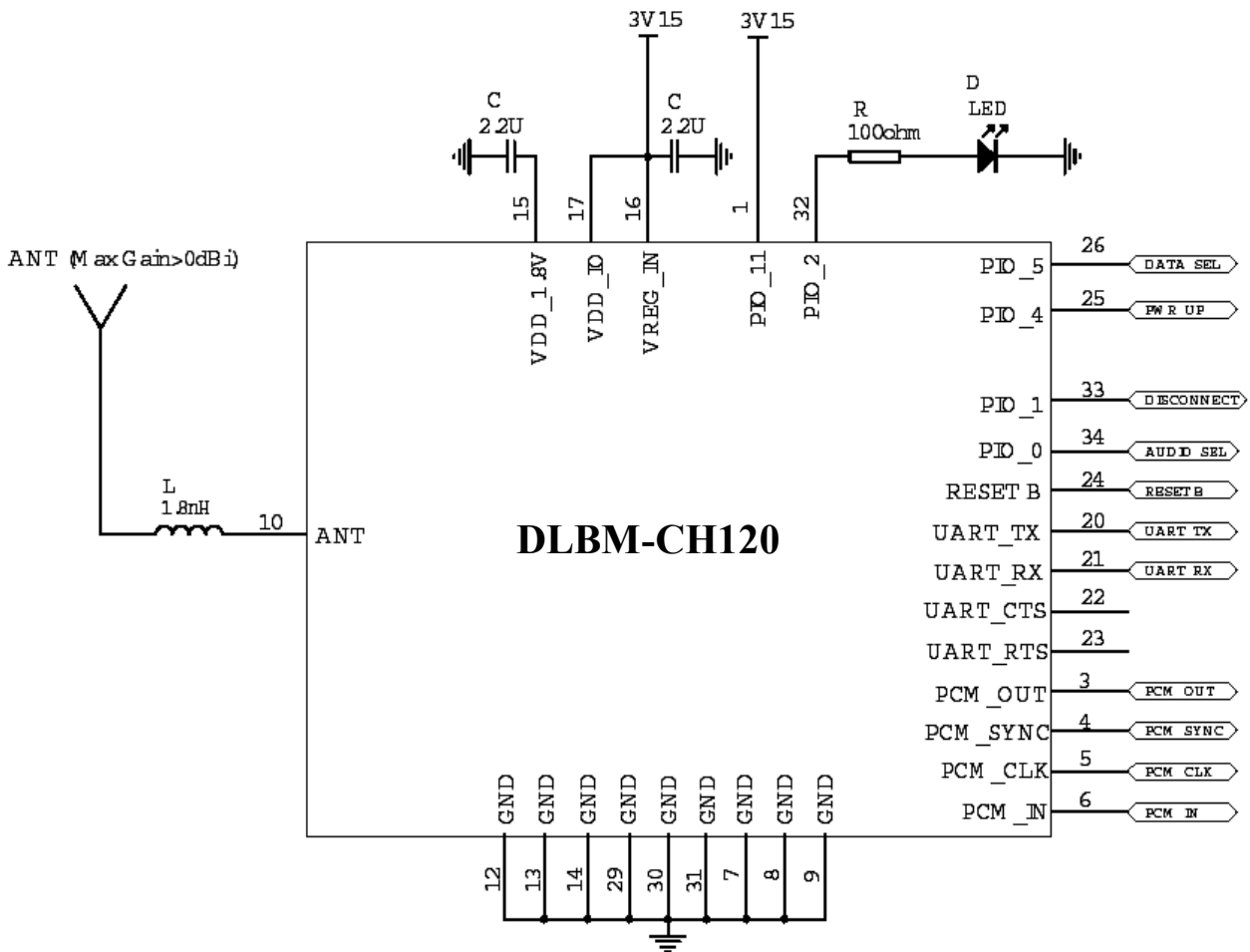

**Figure 4. 2.7~3.6V Supply**

\*\*\*Important: The circuit is offered without warranty and Delta is unable to accept any liability for direct or consequential loss associated with their use. It is therefore important for designers to ensure that their Bluetooth handphone design is properly evaluated in a Design Verification Test. The results of the Design Verification Test should be used to assess the suitability of the handphone for manufacture.\*\*\*

## 9. PIO Setting

PIO	Assignment	Function (* = re-assignable via PSKEY_USR_17)
PIO[0]	<b>AUDIO_SEL*</b> <Output>	Audio service indicator output to host (or to hardware select features): configurable for each profile
PIO[1]	<b>DISCONNECT_CON*</b> <Input>	Service disconnect input (disconnects an RFCOMM connection when using data profiles, as a UART parser is not available)
PIO[2]	<b>CLOCK_REQ</b> <Output>	Output request signal, asserted when BlueCore2/3 requires an external clock source to be enabled. *Assign to LED.
PIO[3]	<b>CLOCK_REF</b> <Input>	Input which logically OR's with the CLOCK_REQ line, to allow an external device to request the system clock through BlueCore-Handphone
PIO[4]	<b>PWR_UP*</b> <Output>	Host communications wake up signal output (indicates imminent UART communications to the host)
PIO[5]	<b>DATA_SEL*</b> <Output>	Data service indicator output to host (or to hardware select features): configurable for each profile
PIO[11]	<b>CLOCK_SEL2</b> <Input>	Determines clock frequency (13, 16, 19.2 or 26 MHz, via combination of pullups with CLOCK_SEL1)

## 10. Basic Embedded Architecture

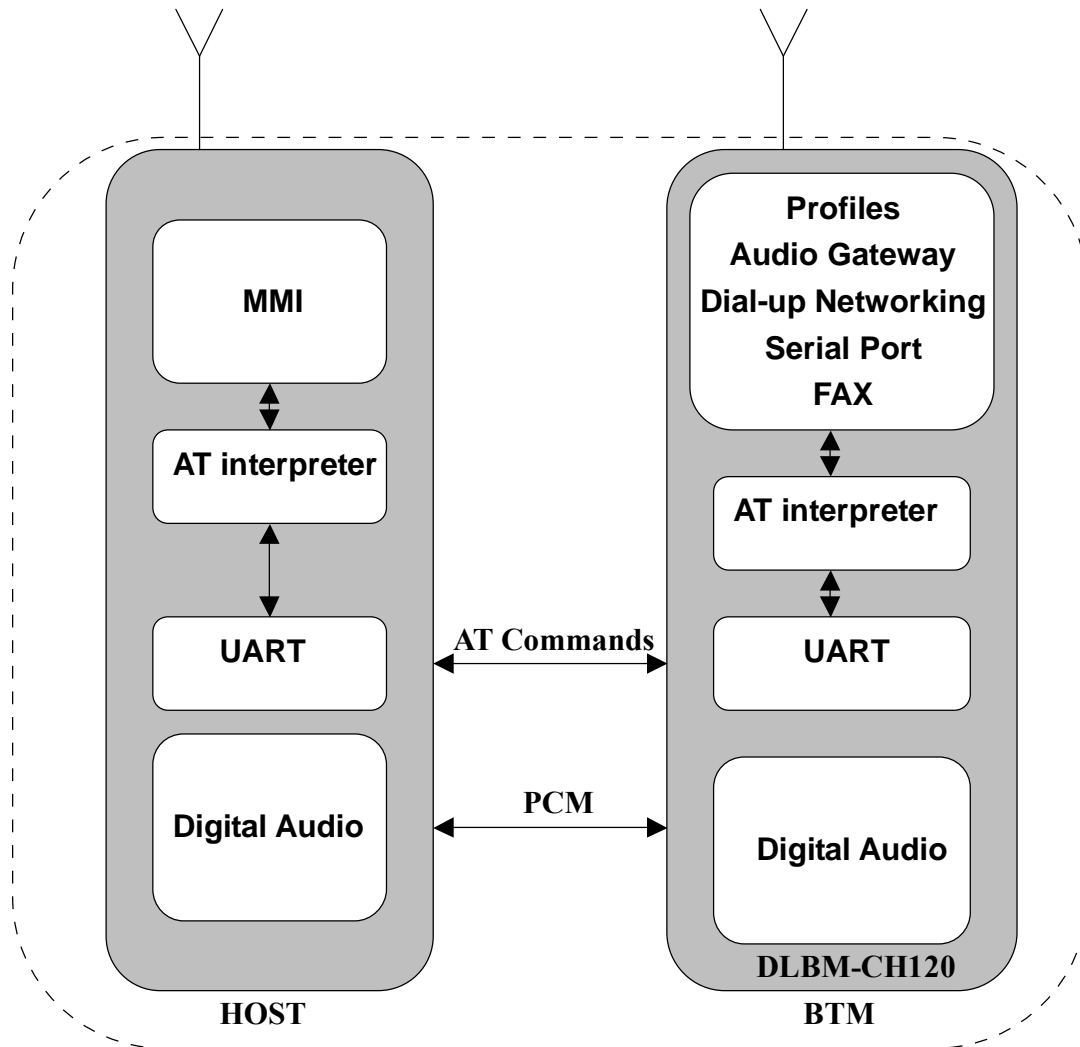

**Figure 5. Embedded Architecture**





## 11. Hardware connection

DLBM-CH120 requires the following hardware connections:

- I Serial communications port with or without hardware flow control.
- I PCM interface for audio gateway profile.

## 12. Mobile Phone Host requirements

The DLBM-CH120 is designed to connect to the existing audio and data connections which or almost always made available on any mobile phone. This removes the need for any baseband software modifications on the part of the host controller since these connections already exist.

The mobile phone designer need simply design a Bluetooth Man-Machine interface in order to do the following functions:

- I Bluetooth Neighborhood inquiry
- I Select, enter PIN and pair with a remote device
- I Show the status of a currently connected Bluetooth service.
- I Limited control of the Bluetooth link i.e. SCO creation (automatic option also available), in-band / out-of band ring determination etc.

Since all the profiles are handles on DLBM-CH120 and a simple AT command set is utilized, there is minimal effort and time to market for the mobile phone company.

## 13. Software architecture

### 13.1 Initialization and start-up

When DLBM-CH120 is initially turned on, the DLBM-CH120 firmware will request configurations data from the host using the +CCFG command. The host will download the PSKEYS, Bluetooth address and friendly name at this point and when it has finished configuring the device, will initiate a warm reset via the BCCMD interface.

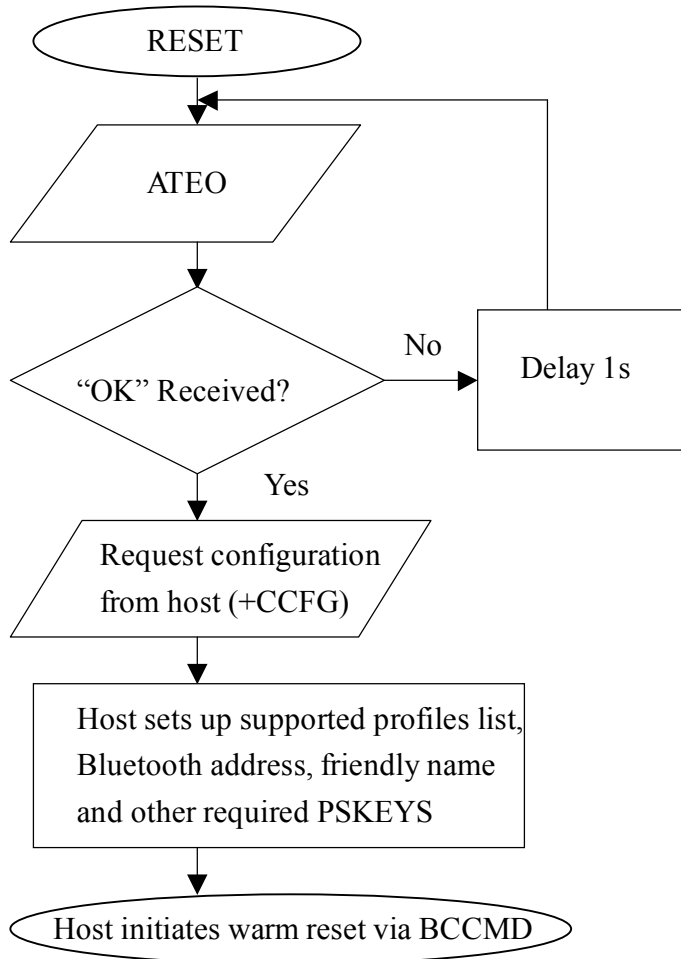

Figure 6. Software Architecture

### 13.2 Setting PSKeys

Setting the PSKEYS consist of three elements in the AT+SETPS command. These elements are:

- I The Pskey address which is a four digit word formatted in ASCII that represents the address of the key to be set. Therefore, to change the contents of address 0x0108, this field will be set to "0108".
- I The data string which is made up of multiples of four digit words. These word will be filled in the respective PSKey address's data field. E.g. "000112349876" will enter the word 0001 1234 9876 into the selected PSKEY.
- I The store type. Typically this should be set to 8 to select the Ram are of PSKEYS.

An example of setting the PSKEYS is to set the crystal frequency trim :-

```
AT+SETPS=01f6,001d,0008.
```

To set a string value such as the friendly name, the host must prefix the data field with 's' i.e. AT+SETPS =0108,sHandphone,0008. This will change the friendly name to "Handphone"

To read a PSKEY, the host must use the AT+GETPS command e.g. AT+GETPS=01f6 will return the crystal frequency trim value.

To initiate a warm reset, the host must use the BCCMD protocol using the varid 0x4002 e.g. AT+BCCMD=4002,0002,0000.

One of the field that must be set is the supported profiles list or PSKey address 0x028d

### 13.3 Supported profiles list (0x028d)

During the configuration process, the host must set up the supported profile list in PSKEY\_USR\_3 as follows:

Bit 7	Bit 6	Bit 5	Bit 4	Bit 3	Bit 2	Bit 1	Bit 0
Reserved	Reserved	Reserved	Fax	Handsfree	DUN	SPP	Headset

Setting the respective bit will cause this profile to be registered after the warm reset.

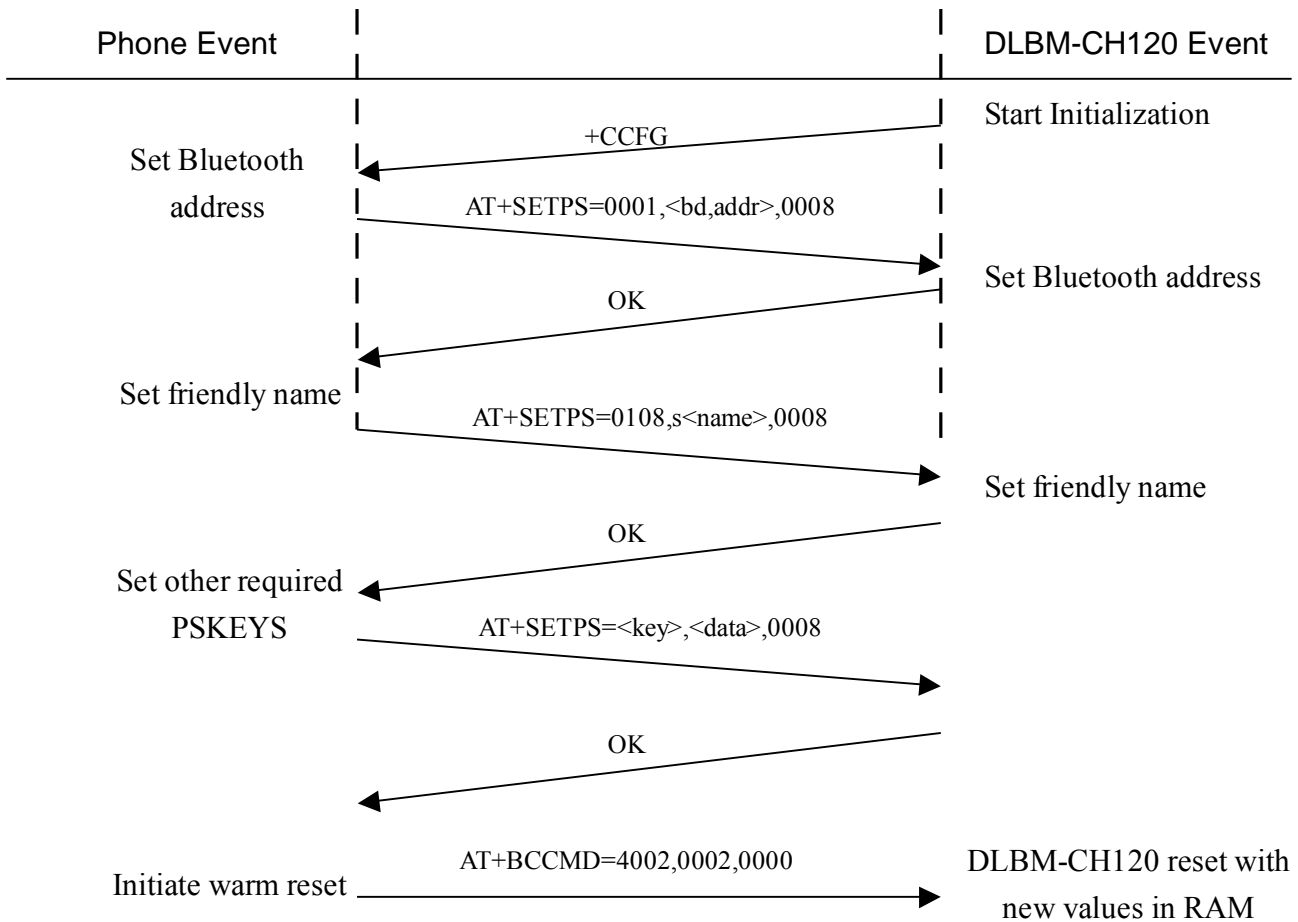

### 13.4 Device Registration process

Once the configuration process has completed, and the warm reset has been initiated, the host must register the trusted devices with the firmware. The host can register devices at any time after the DLBM-CH120 as sent the +CRREG request command. Once the device registration command has been sent from the host, the host must wait for the OK response from the DLBM-CH120 before registering the next device.

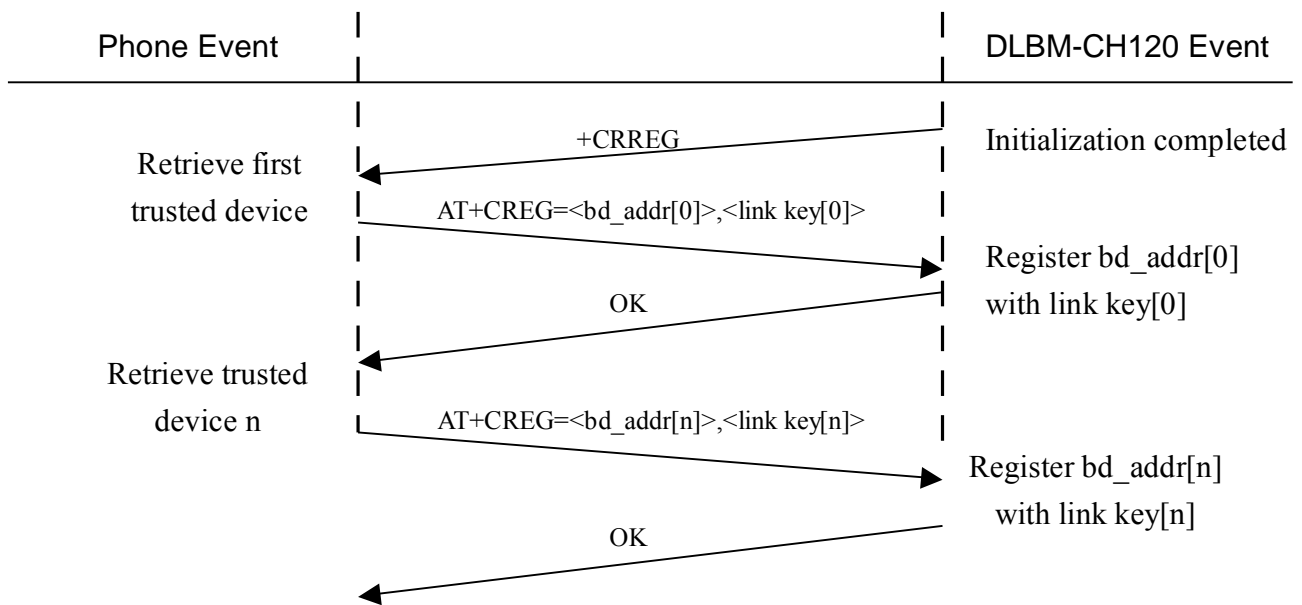

## 13.5 Pairing Process

The sequence to pair the DLBM-CH120 with external remote devices is done as follows:

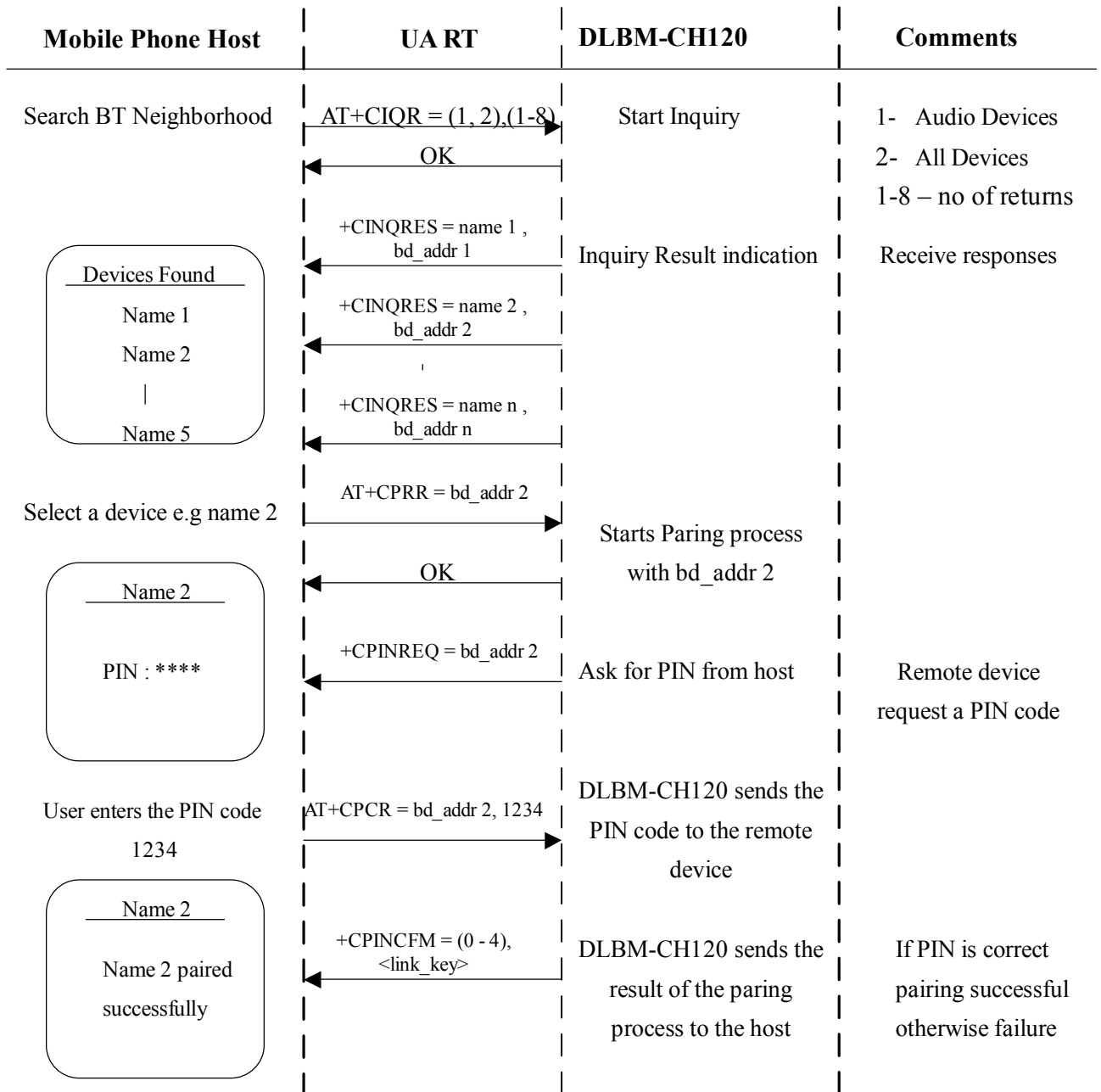



*Preliminary*

## **DLBM-CH120**

---

A "+CINQCFM=<status>" message will be sent to the host indicating why an inquiry is finished. This may be due to inquiry cancellation (e.g. when the user selects a device in the middle of an inquiry), Inquiry complete when the inquiry timer has expired, or maximum number of responses has been received.



# DLBM-CH120

## 13.6 Incoming call is received (out-of-band ring used)

Mobile Phone Host	UART	DLBM-CH120	Comments
Connect request to headset	AT+CCMR=<bd_addr>,1,1	Connect request with device bd_addr	Handphone will attempt a connection
Bluetooth connection established	+CRFCSTAT=bd_addr,0	RFCComm connection established	
Headset Profile	+CPROFILE = 1		
Incoming Call	RING	Send Ring command	Headset plays ring sequence
Call answered	+CKPD=200	DLBM-CH120 can answer automatically (PSKEY_USR11 : 8)	User answers call
If +CKPD = 200 then ask for SCO	AT+CASR=0	DLBM-CH120 establishes a HV3 SCO connection	Audio path open
	+CSCOSTAT=0	DLBM-CH120 indicates SCO	
Call Disconnected	+CKPD=200	DLBM-CH120 receives AT+CKPD = 200 command	User disconnects call
Phone indicates call disconnection	NO CARRIER	DLBM-CH120 removes SCO connection	Audio lost
	+CSCOSTAT=3		





Preliminary

## DLBM-CH120

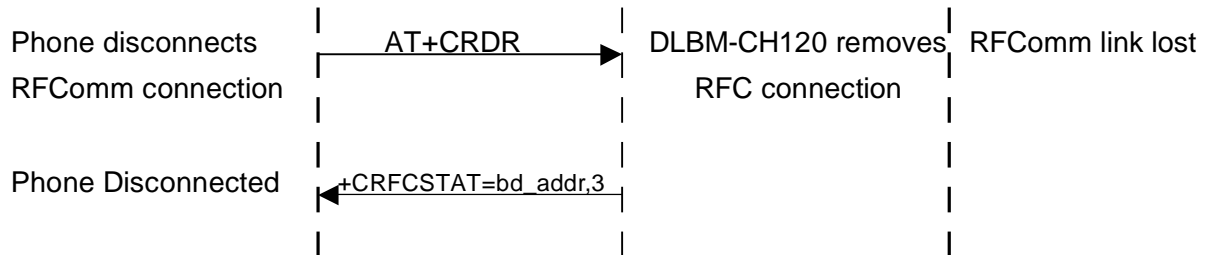



# DLBM-CH120

## 13.7 Incoming call is received (in-band ring used)

Mobile Phone Host	UART	DLBM-CH120	Comments
Incoming Call	AT +CCMR=bd_addr,1,1	Connect request with bd_addr	DLBM-CH120 will attempt a connection unless a service level connection already exists
Bluetooth connection established	+CRFCSTAT=bd_addr,0	RFCOMM connection established	
Headset profile	+CPROFILE=1		
Incoming Call	RING	DLBM-CH120 opens audio path	Audio path open Headset plays in band ring tone from phone
	+CSCOSTAT=0	DLBM-CH120 indicates SCO status	
Call answered	+CKPD=200	DLBM-CH120 indicates button press	User answers call
Call Disconnected	+CKPD=200	DLBM-CH120 receives AT+CKPD = 200 command	User disconnects call
Phone indicates call disconnection	NO CARRIER	DLBM-CH120 removes SCO connection	Audio lost
	+CSCOSTAT=3		
Bluetooth connection lost e.g. out of range	+CRFCSTAT=bd_addr,3	Example of user goes out of range	RFCOMM link lost



### 13.8 Data services

The DLBM-CH120 supports the following data services

- I Serial Port Profile (+CPROFILE = 2)
- I Dial-up networking (+CPROFILE = 3)
- I Handsfree Profile (+CPROFILE = 4)
- I Fax (+CPROFILE = 5)

The default state of the firmware is to always be in idle. Therefore to put the device into connectable mode, the host must issue the AT+CCSR command.

On connection of a service from a remote devices, the firmware will indicate the status of the service level connection with +CRFCSTAT = <bd\_addr>,0. Thereafter the service type will be indicated with +CPROFILE=<service>.

At this point, DLBM-CH120 will route all traffic passing over the RFCComm layer directly to the UART and vice versa. Therefore, all "Fone Suite" applications will run over the serial port profile allowing the use of features such a sync, SMS, calendar etc over Bluetooth.

Dial-up networking and fax operations will also directly route the RFCComm traffic over UART, therefore all modem settings for the mobile phone will be configured on the remote device configuration settings.

When a service is disconnected, DLBM-CH120 will indicate the removal of the service level connection with +CRFCSTAT=<bd\_addr>,3.



**13.9 SPP, DUN and Fax connections**

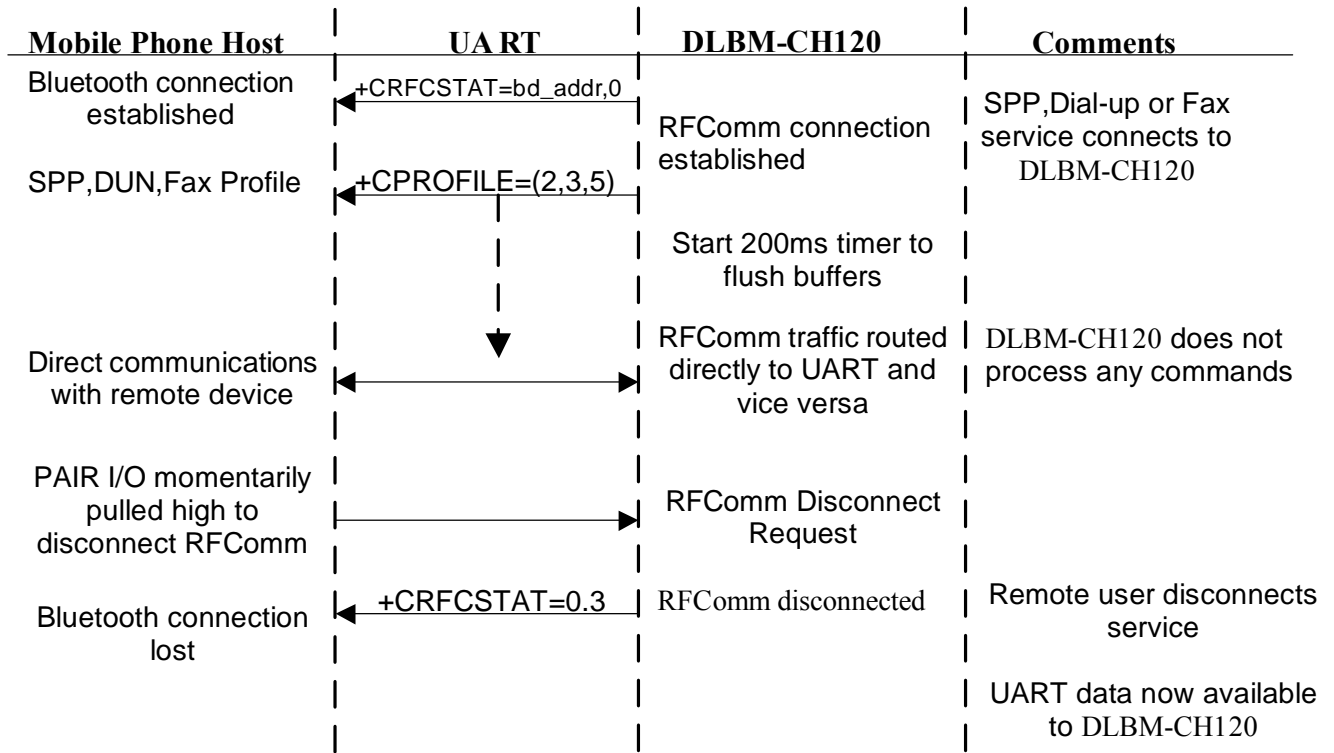

When the Dial-up Networking, SPP or FAX profiles are activated, DLBM-CH120 will initiate two actions:

- Change the mode state hardware output according to the setting is PSKEY\_USR18. It will also issue the data stored in PSKEY\_USR32 (SPP service connected), PSKEY\_USR33 (DUN service connected) or PSKEY\_USR35 (Fax service connected) which may be required by certain mobile phones to switch modes.
- Immediately create a direct link between the UART data and RFComm data. At this point, the DLBM-CH120 is not involved in any data between the two devices.



On disconnection of the RFCOMM link, the mode state hardware output will change to the default mode and issue the data stored in PSKEY\_USR30

To ensure that the mobile phone does indeed disconnect on the loss of an RFCOMM link, PSKEY\_USR36 can be used to store the text string that will unconditionally disconnect the phone from the network (e.g. +++ATH\r). An alternative method is to use the DATA\_SEL I/O which will invert state for a period of 1s after the RFCOMM link has been lost. This can be used to simulate disconnection of a data service.

For the list of DUN and FAX commands, refer to DUN and FAX profile specification from the Bluetooth SIG.

### **13.10 Changing the default states of DLBM-CH120**

It is possible to change the default states to the following:

- Make DLBM-CH120 idle. This is accomplished by sending the AT+CCNR command. This will cancel the last operation and switch off the BlueCore radio.
- Make DLBM-CH120 discoverable. This is accomplished by sending the AT+CDIS= <use authentication> command to BlueCore. This will set-up a page and inquiry scan process so that the device is discoverable and connectable to other Bluetooth devices. This has the disadvantage of increasing the power consumption of DLBM-CH120. If Use Authentication is set then the DLBM-CH120 will request a PIN on first connection to the remote device.
- Make DLBM-CH120 connectable. This is accomplished by sending the AT+CCSR=<use authentication> command to device. This will set-up a page scan process only so that the device is only connectable to other Bluetooth devices which know its address already. If Use Authentication is set then the firmware will request a PIN on first connection to the remote device.



*Preliminary*

## **DLBM-CH120**

---

- You can restart the DLBM-CH120 software by sending a AT+CRST command. This causes the software to panic and then relies on the watchdog timer to reset the device.



### **13.11 Using Low Power Modes with the AT command set**

Since the standard UART protocol does not allow for the retry of transmission when information is lost over the UART, DLBM-CH120 uses a specific set of instructions to cause the device to exit out of deep sleep.

The software recognises the AT command "AT+CWUP" from the host and will respond with a "WAKEOK= <expected minimum wakeup time>". Therefore the host can issue the AT+CWUP command repetitively until it receives the WAKEOK command response. The parameter which is associated with the response, indicates the minimum time that the DLBM-CH120 will be awake and is sent in millisecond units. Therefore the host does not have to send AT+CWUP commands during this period. To reduce latencies, it is possible to re-transmit the second AT+CWUP command within 100ms of the first AT+CWUP command since there will be a high probability that DLBM-CH120 would now be awake. Thereafter it is suggested to wait at least 5000ms between subsequent AT+CWUP commands in order for DLBM-CH120 to respond.



# DLBM-CH120

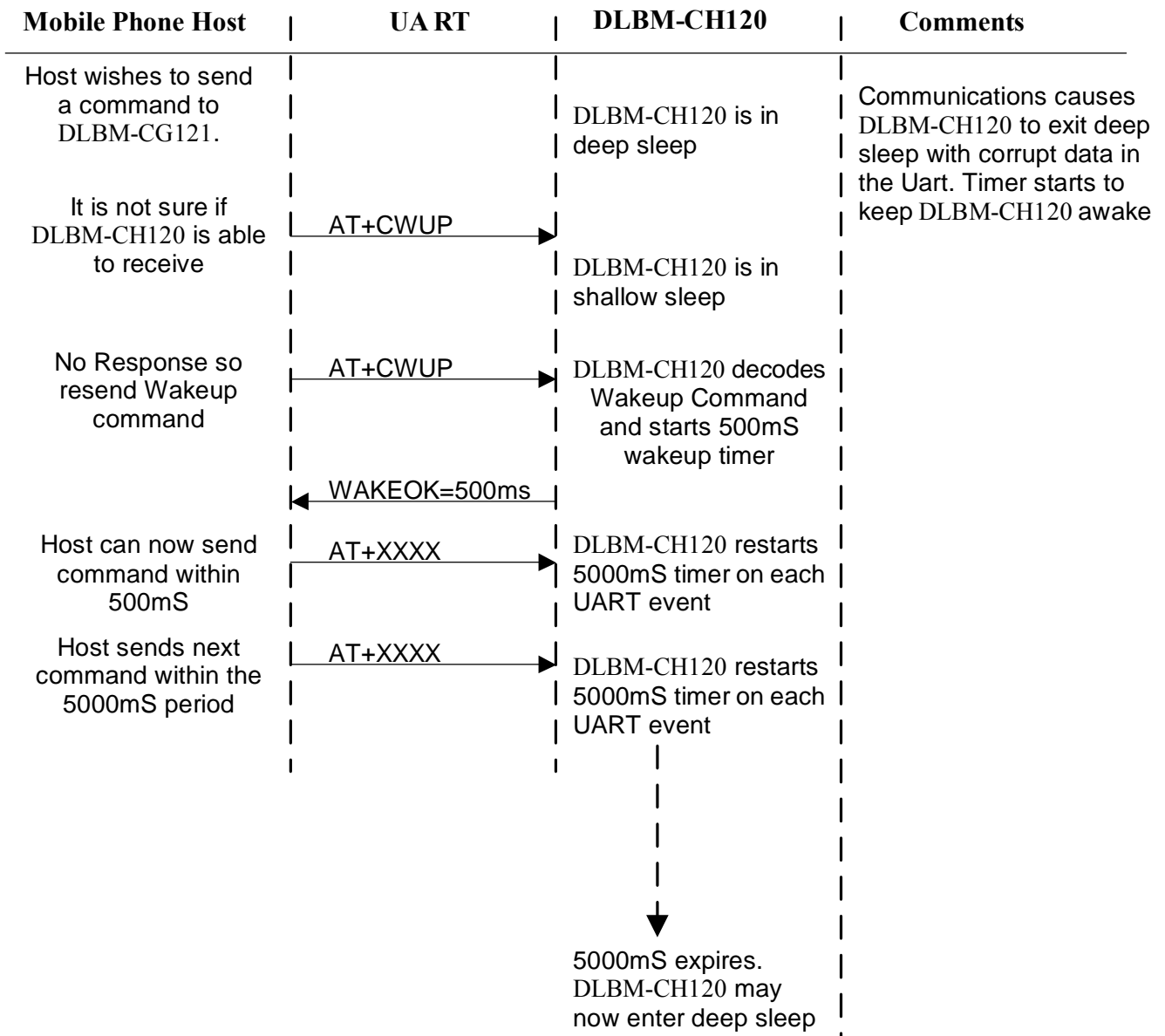





### 13.12 Improving Execution Time

It is possible to improve the execution time for known events by setting flags in PSKEY\_USR11 as follows:

PSKEY_USR11 (Bit Position)	Function
0-5	Reserved
6	Automatically connect SCO on receipt of ATA from Handsfree device
7	Automatically disconnect SCO on receipt of AT+CHUP from Handsfree device
8	Automatically connect SCO on receipt of AT+BVRA=1 from Handsfree device
9	Automatically connect SCO on receipt of AT+CKPD=200 from Headset device
10	Automatically connect SCO on receipt of +CIEV:<call>,1 from host and Automatically disconnect SCO on receipt of +CIEV:<call>,0 from host

### 13.13 Hands Free Operation

In order for hands free to work correctly there must be a serial link to the GSM phone supporting the GSM07.07 generic commands for hands free operation. These include the following:

- I . ATA
- I . AT+CHUP
- I . ATDdd..dd;
- I . ATD>nnn;
- I . AT+CCWA
- I . +CCWA
- I . AT+CHLD
- I . AT+CIND=?



- I . AT+CIND?
- I . AT+CLIP
- I . +CLIP
- I . AT+CMER
- I . +CIEV

The above commands are not interpreted by DLBM-CH120 and rely on the mobile phone to respond to these messages. All responses are passed directly to the hands free kit.

All other operation relating to service level connection and Bluetooth operation is handled by DLBM-CH120. In handset mode, some of these commands will be passed to the phone host for interpretation such as AT+BVRA = <n> for voice recognition activation and AT+NREC=<n> for noise cancellation request.

### **13.13.1 Bluetooth Hands Free Profile**

The Bluetooth Hands Free profile is a mixture of analogue and data services. On connection of a Hands Free kit to the phone, the mode state will be Audio. Therefore a phone not supporting audio and data services simultaneously will not be able to support Bluetooth Hands free operation.

The majority of commands used by the Hands Free profile are based on the GSM07.07 AT command set. For all these commands, DLBM-CH120 firmware will simply act as a feed through for the commands and responses. Therefore, commands such as CMER, CIND, ATA, AT+CHUP, ATD etc are not issued by DLBM-CH120 but by the Hands Free kit.

It is still possible, however, to add more functionality to the Bluetooth hands free profile by emulating some of the Bluetooth commands into a mode that the phone supports, e.g. AT+BVRA=1 would initiate a voice tag dial in a Bluetooth phone.

In order to set up the supported features list to be sent with the SDP record, PSKEY\_USR7 stores the Supported Features list in the same order as expected by the Hands Free Profile i.e.



---

PSKEY_USR7(Bit Position)	Function
0	Three way calling
1	Echo cancellation or noise reduction (Unlikely to be supported)
2	Voice Recognition Function (is enabled will cause DLBM-CH120 to initiate a long pulse sequence)
3	In-Band Ring Tone. (If enabled will force an Audio SCO Connection on incoming calls)
4	Attach phone number to tag (Not supported)

### 13.14 Managing the Trusted Device List

Support has been included to manage the trusted device list. The commands associated with this process are as follows:

Registering trusted devices stored within the host. This is done after DLBM-CH120 requests registration of these devices using +CRREG command. The host can then register the devices at any time, keeping in mind that any device not registered, attempting to connect with the Handphone would require authentication.

Therefore, If a device is not a registered device, DLBM-CH120 will go through the process of requesting a PIN, and if successful, will respond with the +CLINK=<bd\_addr>,<link key> response to inform the host of the new devices' link key and address. It would be up to the host to decide whether to add this device to it's trusted device list or not.

Once the device have been registered, they may be removed from DLBM-CH120 security manager by issuing the AT+CTDDEL = <bd\_addr> command. This Bluetooth address will thereafter be deleted from the registry.

The management of the trusted device list is kept within the host, therefore the host may decide how many trusted devices to hold, and may change the name of the remote device name if so required.



### **13.15 Initiating Connections**

It is possible for the host to initiate a connection to a device as follows:

#### **13.15.1 Devices found during inquiry**

After completion of inquiry search, a list of devices will have been sent to the host using "+CINQRES=<name>,<Bluetooth address>". It is possible to connect directly to a device without pairing by issuing the command AT+CMMR=Bluetooth address,<authenticata>, <profile>.

If authenticate is set then DLBM-CH120 will expect a pin code to be issued during the connection process therefore to establish an un-secure connection, the authenticate field must be set to 0 for unauthenticated connections.

The service you wish to connect to will be put into <Profile> as follows:

- 1 – Headset Profile
- 2 – Serial Port Profile
- 3 – Dial-up Network Profile
- 4 – Hands free profile
- 5 – Fax Profile

Once connection to the remote device is established, the normal status commands will be issued by DLBM-CH120 to the host to indicate the status of the connection.

**Please note that one cannot use the AT command set when the DLBM-CH120 is in data mode (i.e. DUN, SPP or FAX) since the UART and RFComm links are directly connected. If the link has to be disconnected by the DLBM-CH120, then the disconnect I/O must be used to disconnect the RFComm link.**



**13.15.2 Connecting to devices in the trusted device list**

Connecting to devices in the trusted device list follows the same procedure as above, but the source will come from the hosts trusted device list. AT+CMMR=<db\_addr in trust device list>,<authenticate>,<profile>

**13.16 Configuring PIO assignments**

The PIO's for DLBM-CH120 can be dynamically configured via PSKEY\_USR17 as follows:

PIO[0]	PIO[1]	PIO[2]	PIO[3]	PIO[4]	PIO[5]	PIO[6]	PIO[7]	PIO[8]	PIO[9]	PIO[10]	PIO[11]
0001	0002	0004	0008	0010	0020	0040	0080	0100	0200	0400	0800

PSKEY\_USR17 consists of four words. Each word is assigned a function as follows:

Word 1 (most significant word)	Word 2	Word3	Word 4
Audio service indicator output	Service disconnect input	Data service indicator output	Host communications wake up signal



**13.17 Input / output indicators for service connections**

There are two indicator outputs which are used to indicate when the service DLBM-CH120 is connected to. These indicators are as set up using PSKEY\_USR\_18 as follows:

B7	B6	B5	B4	B3	B2	B1	B0
*1	X	Fax	Hands Free	DUN	SPP	Headset	Default when idle or in Page Scan

Note \*1)Word 1 – Pulse DATA\_SEL line when RFCComm lost during DUN, FAX and SPP  
Word 2 – Use UART WAKEUP pulse

PSKEY\_USR\_18 consists of two words, The first word sets up the state of the AUDIO\_SEL I/O when in accordance with the above table bit positions. The second word sets up the DATA\_SEL I/O in accordance with the above table bit positions.

These I/O pins can be used to hardware select features or as indications into a host processor.

If Bit 7 is set then DATA\_SEL line will pulse high then low for a period of at least 20ms and then return to the original state. This can be used to wake up a host if necessary.

For example PSKEY\_USR18 = 0013 003c sets up I/O's as follows:

AUDIO\_SEL State = 0x0013 :

Idle	High
Headset	High
SPP	Low
DUN	Low
Hands Free	High
Fax	Low



Preliminary

## DLBM-CH120

---

DATA\_SEL state = 0x003c

Idle	Low
Headset	Low
SPP	High
DUN	High
Hands Free	High
Fax	High

Setting bit 7 (0x80) of this word will generate a minimum 20ms pulse on the PWR\_UP I/O. This can be used if the phone requires a wakeup before Uart communications.



## 14 List of PSKEYS

PSKEY	Function	Comments
3	Supported profiles	Bit 0 – Headset profile Bit 1 – Serial port profile Bit 2 – Dial-up networking profile Bit 3 – Handsfree profile Bit 4 – Fax profile
7	Hands Free Supported Features	Described earlier
9	Time for host communication wakeup signal	In 1ms increments – Time for wake-up pulse to ensure host is ready to receive data
11	General Flags	Bit 0 – Default SCO Flag (0-HV3, 1 HV1) Bit 1 – phone uses in-band ringing for headset Bit 2 – Reserved Bit 3 – Reserved Bit 4 – Reserved Bit 5 – Use 1.28s page scan interval Bit 6 – Automatic SCO creation on ATA Bit 7 – Automatic SCO disconnection on AT+CHUP Bit 8 - Automatic SCO creation on AT+BVRA=1 Bit 9 - Automatic SCO creation on AT+CKPD=200 Bit 10 – Control SCO on call status events
14	Sniff mode parameters	Max interval, min interval, attempts, timeout





Preliminary

## DLBM-CH120

17	PIO configuration settings	Word 1 – Audio service indicator output Word 2 – Disconnect service input Word 3 – Data service indicator output Word 4 – Host wakeup signal
30	Default AT String	Sent to phone when service disconnected
31	Headset Mode AT string	Sent to phone when connected to Headset service
32	SPP Mode AT string	Sent to phone when connected to SPP service
33	DUN Mode AT string	Sent to phone when connected to DUN service
34	Hands Free Mode AT string	Sent to phone when connected to Hands Free service
35	Fax Mode AT string	Sent to phone when connected to Fax service
36	Force Modem Disconnect AT string	Sent to the phone when a DUN service is disconnected
37	Alternative Call Answer string	Used if present, otherwise ATA is used
38	Alternative Call disconnect string	Used if present, otherwise AT+CHUP is used
39	Alternate Call Initiate string	Used to generate last number redial or voice tag via AT commands.

**15. RECOMMENDED REFLOW PROFILE**

**Reflow Profile Used at The Evaluation (Sn-3.0Ag-0.5Cu) –PF606-P**

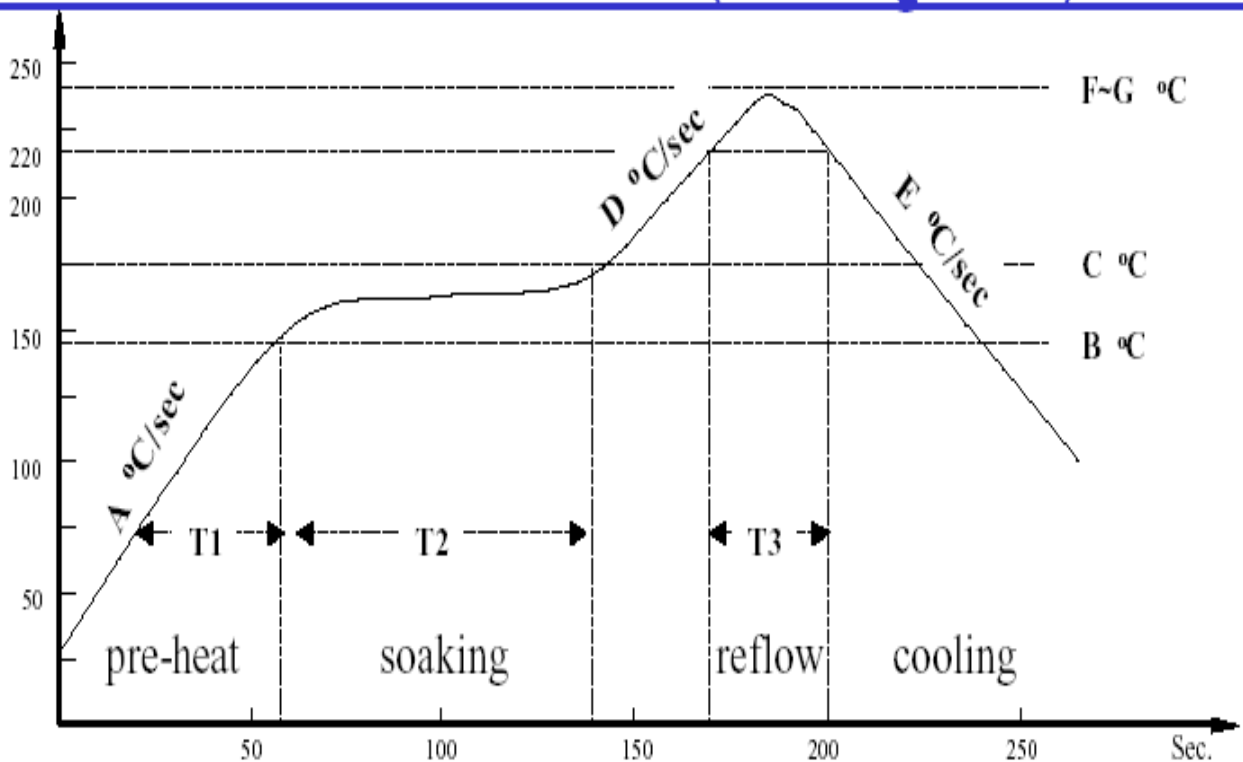

A: ramp up rate during preheat:	1.5~3.0 °C/sec
B-C: soaking temperature:	170± 15 °C
D: ramp up rate during reflow:	1.2~2.3 °C/sec
E: ramp down rate during cooling:	1.7~2.2 °C/sec
F-G: peak temperature:	240± 10 °C
T1: preheat time:	65± 15 sec
T2: dwell time during soaking:	75± 15 sec
T3: time above 220 °C :	30± 10 sec

**Figure 7. REFLOW PROFILE**

**16.Pin description**

<b>Pin No.</b>	<b>Name</b>	<b>Description</b>
1	PIO_11	Programmable I/O terminal
2	PIO_9	Programmable I/O terminal
3	PCM_OUT	/Synchronous data output
4	PCM_SYNC	/Synchronous data sync
5	PCM_CLK	/Synchronous data clock
6	PCM_IN	/Synchronous data input
7	Gnd	
8	Gnd	
9	Gnd	
10	ANT	RF input/output
11	AIO_0	Programmable input/output
12	Gnd	
13	Gnd	
14	Gnd	
15	Vdd_1.8V	Refer to Power supply diagram
16	VREG_IN	Refer to Power supply diagram



Preliminary

## DLBM-CH120

17	VDD_IO	Refer to Power supply diagram
18	USB_DN	USB data minus
19	USB_DP	USB data plus with selectable internal 1.5kohm pull-up resistor
20	UART_TX	UART data output active high
21	UART_RX	UART data input active high
22	UART_CTS	UART clear to send active low
23	UART_RTS	UART request to send active low
24	Reset_B	Reset if low
25	PIO_4	Programmable input/output line
26	PIO_5	Programmable input/output line
27	PIO_10	Programmable input/output line
28	PIO_3	Programmable input/output line
29	Gnd	
30	Gnd	
31	Gnd	
32	PIO_2	Programmable input/output line
33	PIO_1	Programmable input/output line
34	PIO_0	Programmable input/output line
35	SPI_MOSI	Serial Peripheral Interface data input



*Preliminary*

## **DLBM-CH120**

---

<b>36</b>	SPI_MISO	Serial Peripheral Interface data output
<b>37</b>	SPI_CLK	Serial Peripheral Interface clock
<b>38</b>	SPI_CSB	Chip select for Serial Peripheral Interface, active low

**17. Dimensions (mm)**

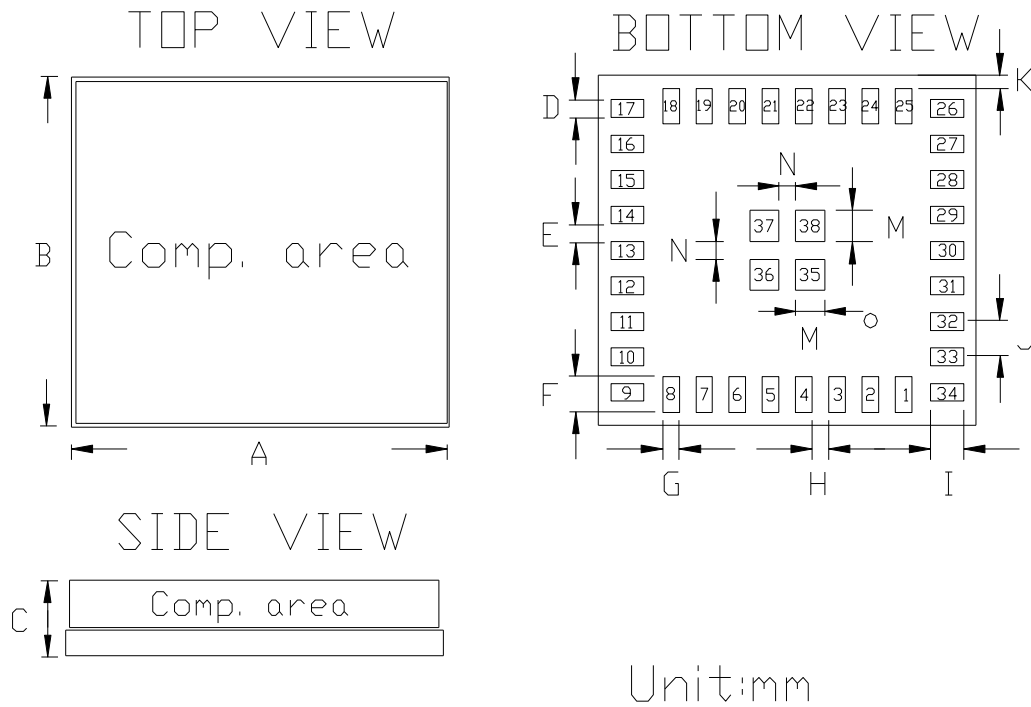

A	$9.1 \pm 0.2$	E	$0.4 \pm 0.1$	I	$0.8 \pm 0.1$	N	$0.4 \pm 0.1$
B	$7.9 \pm 0.2$	F	$0.8 \pm 0.1$	J	$0.8 \pm 0.1$		
C	$1.5 \pm 0.2$	G	$0.4 \pm 0.1$	K	$0.3 \pm 0.1$		
D	$0.4 \pm 0.1$	H	$0.4 \pm 0.1$	M	$0.7 \pm 0.1$		

**Figure 8. Output pin dimensions**

## 18. Layout Guide

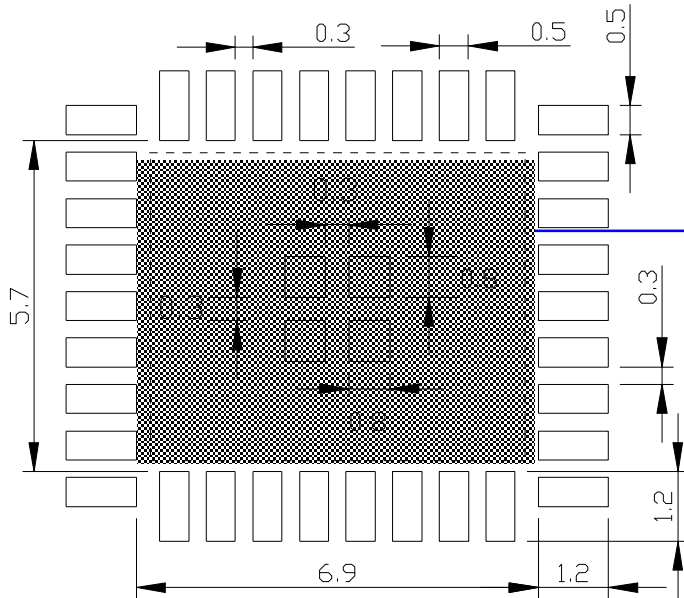

Don't place the ground on the top layer (Inside area)

Unit: mm

Figure 9. Land Pattern

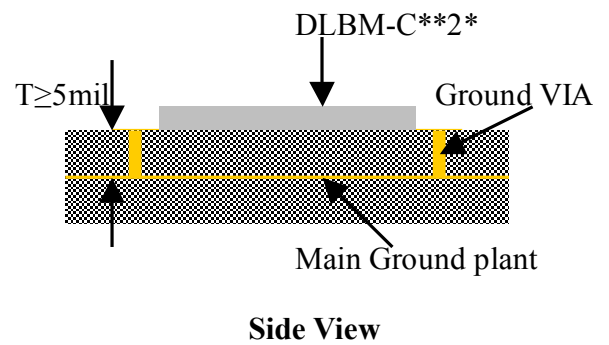
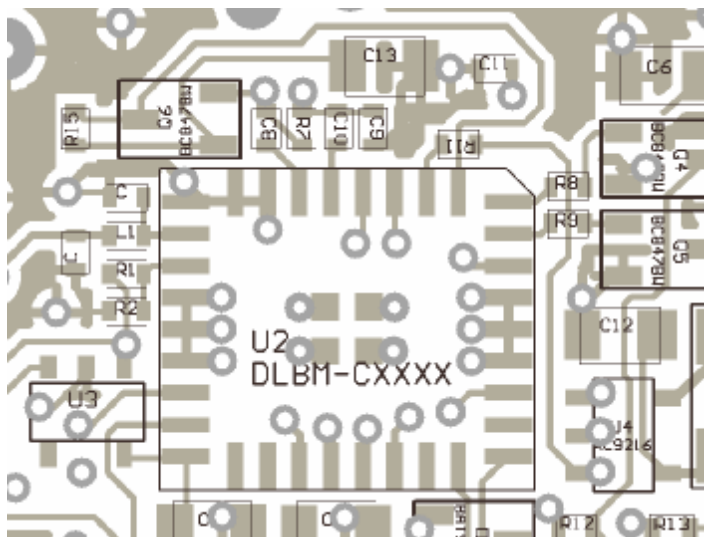

Figure 10. Layout Example



Preliminary

## DLBM-CH120

### 20. Record of changes

Date	Content of change
Jan 21, 2005'	1) Revise the PIO setting List
April 6, 2005'	Include SPI connection
April 20, 2005'	Includes pin dimension tolerance

### Contact information:

Website: <http://www.deltaww.com>

Email: [Jonathan.Chen@delta.com.tw](mailto:Jonathan.Chen@delta.com.tw)

Tel No.: 886-3-3591968#2925

Data Sheet

April 20, 2005

Proprietary Information and Specifications are Subject to Change