

# VSC7980, 7981, 7982

**VITESSE**

## Up to 11.3 Gb/s 3.3V: VCSEL, DML, EML Laser/Modulator Driver Family



### APPLICATIONS:

- ▶ SONET OC-192 and SDH STM-64 Transmission Systems
- ▶ GR-253: SR, IR and LR
- ▶ 10 Gigabit Ethernet and 10 Gigabit Fibre Channel
- ▶ IEEE802.3ae 10GBASE-SR,LR,ER
- ▶ XFP MSA Transceiver Modules
- ▶ XENPAK, XPAK, X2 and 300-pin MSA Transponder Modules

### FEATURES:

- ▶ +3.3V Power Supply for Low Power
- ▶ Duty Cycle, Output Modulation and Output Bias Level Controls
- ▶ VSC7980: 200mW Typical Power Dissipation Including 50Ω Load
- ▶ VSC7981: 800mW Typical Power Dissipation Including 25Ω Load
- ▶ VSC7982: 930mW Typical Power Dissipation Including 50Ω Load
- ▶ Sourcing and Sinking Bias Current Outputs
- ▶ 50ohm Back-terminated AC-coupled Outputs
- ▶ Automatic Power Control
- ▶ Support for Extinction Ratio Control
- ▶ XFP-Compliant Current Disable and Faults
- ▶ Built-in support for IEC-60825 Eye Safety
- ▶ Small package: 5mm x 5mm 32 pin QFP-N

### BENEFITS:

- ▶ On Chip Op-amps Provide Stability and Control Resulting in Reduced Component Count
- ▶ Small 5mm x 5mm Low-cost QFP-N Packaging Optimized for Small Footprint Applications, Including XFP Modules.
- ▶ Supports Both APC and ERC Control Loops for Leading Edge Designs
- ▶ On Chip Sourcing and Sinking Bias Current Outputs for IEC-60825 Eye Safety, Reducing Both Circuit and Firmware Design Complexity

### SPECIFICATIONS:

- ▶ DATA Rate up to 11.3 Gb/s
- ▶ Single-Ended Input Voltage Sensitivity: 300mV
- ▶ Differential Input Voltage Sensitivity: 300mV (150mV per side)
- ▶ Output Modulation Voltage Compliance 1.5 V
- ▶ Minimum Output Modulation Current
  - VSC7980 - 1 mA
  - VSC7981 - 20 mA
  - VSC7982 - 20 mA or 1V
- ▶ Maximum Output Modulation Current
  - VSC7980 - 15 mA
  - VSC7981 - 80 mA
  - VSC7982 - 2.5V or 50 mA, VCC2 = 3.3V
  - VSC7982 - 3V or 60 mA, VCC2 = 5V
- ▶ Power Supply Voltage +3.3 V
- ▶ Minimum Ambient Temperature -40 °C
- ▶ Case Temperature -20 to +100 °C

# VSC7980, 7981, 7982

## Up to 11.3 Gb/s 3.3V: VCSEL, DML, EML Laser/Modulator Driver Family

### GENERAL DESCRIPTION:



The VSC7980, VSC7981 and VSC7982 are low power 10Gb/s laser and modulator drivers for both Telecommunications and Data Communications. Applications include modules and line cards for OC-192/STM-64 SONET/SDH as well as 10GE/10GFC protocols. The VSC7980 is intended to drive Vertical Cavity Surface Emitting Lasers (VCSEL). The VSC7981 is intended to drive Direct Modulated Lasers (DML) such as Distributed Feedback (DFB) and Fabry-Perot (FP) Lasers with a 25 Ohm characteristic impedance. The VSC7982 is intended to drive DML and Externally Modulated Lasers (EML) such as Electro Absorption modulators with a 50 Ohm characteristic impedance.

The 50 Ohm on-chip back-termination simplifies the process of matching the laser to the driver. The VSC7980, VSC7981 and VSC7982 are equipped with XFP-compliant fault indicators (FLTN\_DISN and EOLN), dual disable control (FLTN\_DISN and TX\_DIS), Automatic Power Control (APC), temperature sensor, voltage reference, various eye safety features and Extinction Ratio Control (ERC) with an external micro controller. These device controls and monitors were designed to be controlled with set resistors, potentiometers, or Digital-to-Analog Converters (DACs) and monitored with Analog-to-Digital Converters (ADCs) for ultimate flexibility in module design. The VSC7980, VSC7981 and VSC7982 are available in a 5mm x 5mm 32-pin plastic QFP-N package.

### BLOCK DIAGRAMS:

Configuration with a Common Cathode Laser

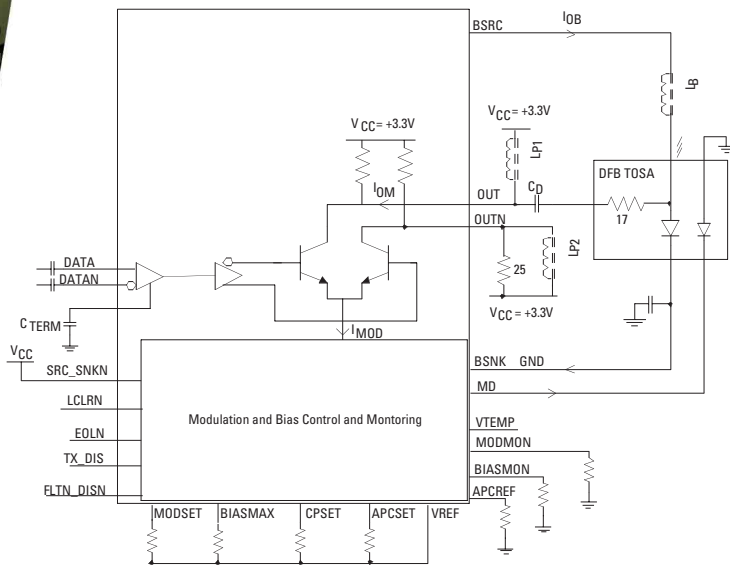

Configuration with a Common Anode Laser

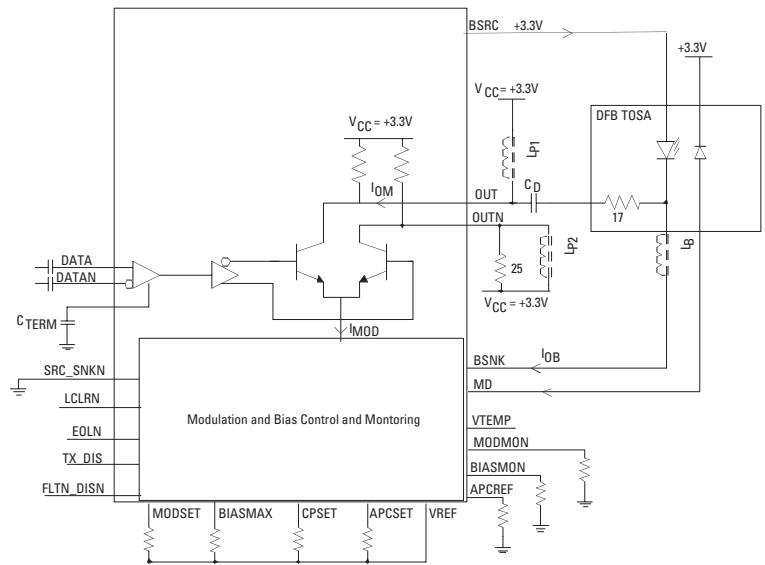

For more information on Vitesse Products visit the Vitesse web site at [www.vitesse.com](http://www.vitesse.com) or contact Vitesse Sales at (800) VITESSE or [sales@vitesse.com](mailto:sales@vitesse.com)

©2004 Vitesse Semiconductor Corporation

Vitesse, ASIC-Friendly, FibreTimer, TimeStream and Snoop Loop are trademarks of Vitesse Semiconductor Corporation. All other trademarks or registered trademarks mentioned herein are the property of their respective holders. Vitesse Semiconductor Corporation ("Vitesse") retains the right to make changes to its products or specifications to improve performance, reliability or manufacturability. All information in this document, including descriptions of features, functions, performance, technical specifications and availability, is subject to change without notice at any time.

**VITESSE**

741 Calle Plano  
Camarillo, CA 93012, USA  
Tel: +1 805.388.3700  
Fax: +1 805.987.5896  
[www.vitesse.com](http://www.vitesse.com)