

## HIGH VOLTAGE IGNITION COIL DRIVER POWER IC

### TARGET DATA

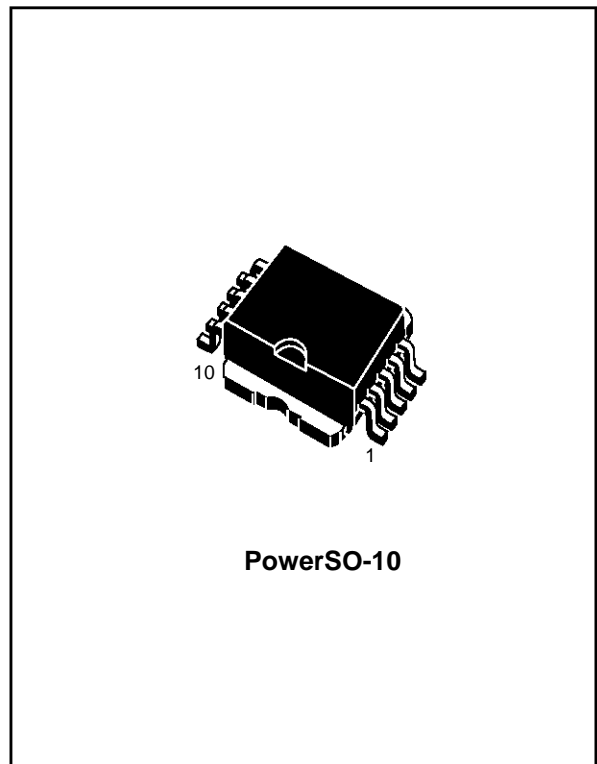
TYPE	V <sub>CL</sub>	I <sub>CL</sub>	I <sub>CC</sub>
VB125SP	370 V	9 A	200 mA

- PRIMARY COIL VOLTAGE INTERNALLY SET
- COIL CURRENT LIMIT INTERNALLY SET
- LOGIC LEVEL COMPATIBLE INPUT
- BATTERY OPERATION
- SINGLE FLAG-ON COIL CURRENT
- TEMPERATURE COMPENSATED HIGH VOLTAGE CLAMP

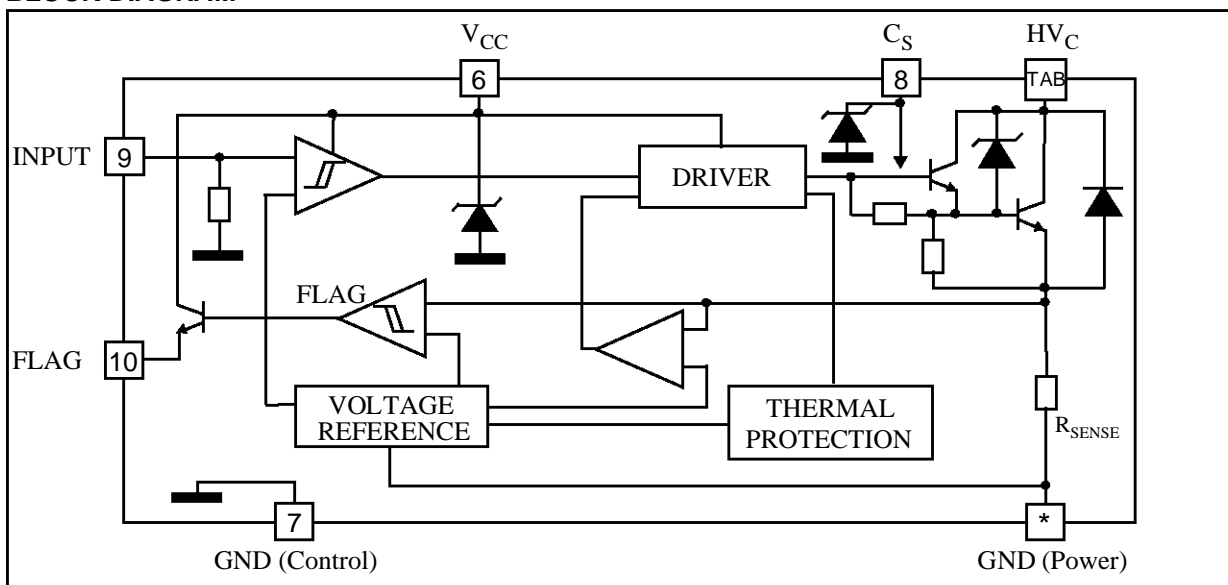
### DESCRIPTION

The VB125SP is a high voltage power integrated circuit made using SGS-THOMSON Microelectronics Vertical Intelligent Power Technology, with vertical current flow power darlington and logic level compatible driving circuit.

The VB125SP can be directly biased by using the 12V battery voltage, thus avoiding to use a low voltage regulator. It has built-in protection circuits for coil current limiting and collector voltage clamping. It is suitable as smart, high voltage, high current interface in advanced electronic ignition system.



### BLOCK DIAGRAM



(\*) Pins 1...5

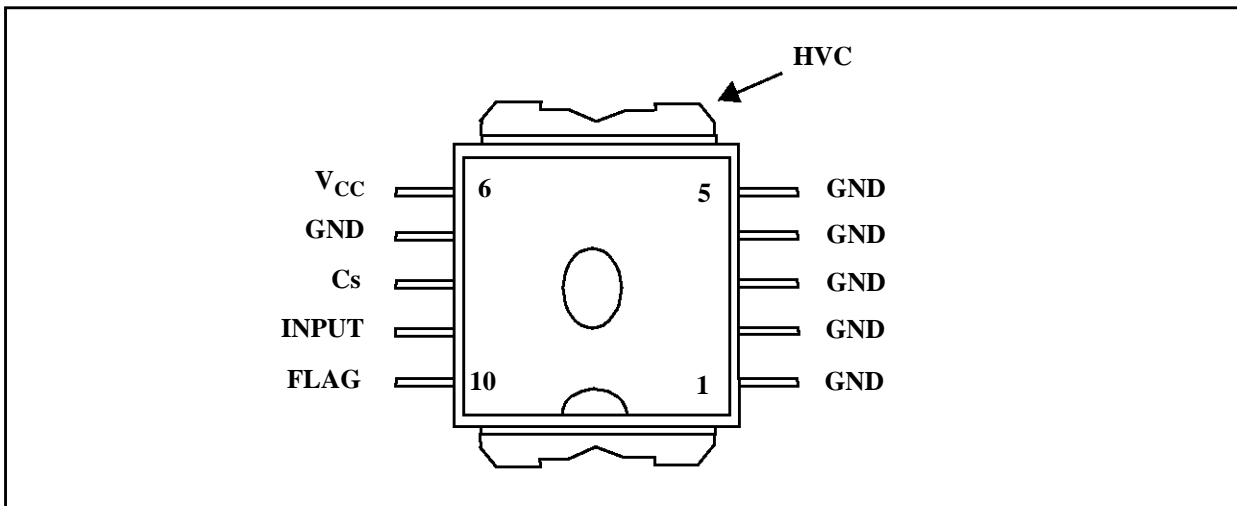
**ABSOLUTE MAXIMUM RATING**

Symbol	Parameter	Value	Unit
HV <sub>C</sub>	Collector Voltage (Internally Limited)	-0.3V to V <sub>CLAMP</sub>	V
I <sub>C</sub>	Collector Current (Internally Limited)	10	A
V <sub>CC</sub>	Driving Stage Supply Voltage	-0.2 to 40	V
I <sub>CC</sub>	Driving Circuitry Supply Current	400	mA
I <sub>S</sub>	Logic Circuitry Supply Current	100	mA
V <sub>IN</sub>	Input Voltage	-0.3 to 6	V
P <sub>TOT</sub>	Power Dissipation	TBD	W
V <sub>ESD</sub>	ESD Voltage (HVC Pin)	-4 to 4	KV
V <sub>ESD</sub>	ESD Voltage (Other Pin)	-2 to 2	KV
T <sub>j</sub>	Operating Junction Temperature	-40 to 150	°C
T <sub>STG</sub>	Storage Temperature Range	-55 to 150	°C

**THERMAL DATA**

R <sub>thj-case</sub>	Thermal Resistance Junction - Case	MAX	1.2	°C/W
R <sub>thj-amb</sub>	Thermal Resistance Junction - Ambient	MAX	62.5	°C/W

**CONNECTION DIAGRAM**



**PIN FUNCTION**

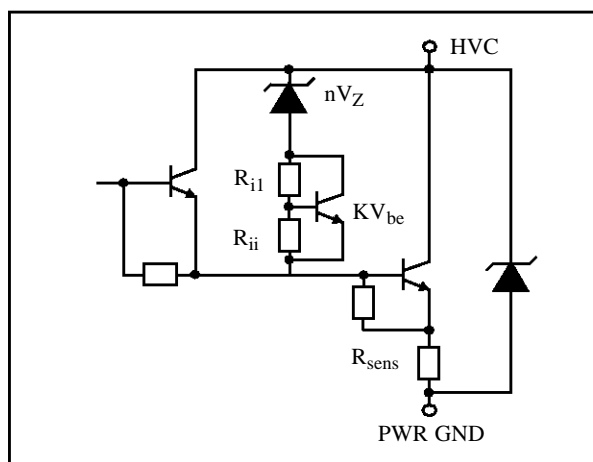
No	Name	FUNCTION
1-5	GND	Emitter Power Ground
6	V <sub>CC</sub>	Logic Supply Voltage
7	GND	Control Ground (*)
8	C <sub>S</sub>	Logic Level Supply Voltage Filter Capacitor
9	INPUT	Logic Input Channel
10	FLAG	Diagnostic Output Signal
TAB	HVC	Primary Coil Output Driver

(\*) Pin 6 must be connected to pins 1-5 externally

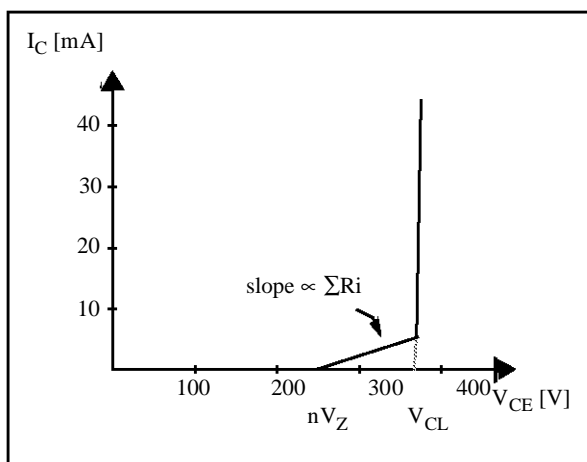
**ELECTRICAL CHARACTERISTICS** ( $V_{bat} = 6$  to  $24V$ ;  $-40^{\circ}C < T_j < 125^{\circ}C$ ;  $R_{coil} = 400$  to  $700m\Omega$  ;  $L_{coil} = 2$  to  $6mH$ ; unless otherwise specified; See Note 1)

Symbol	Parameter	Test Conditions	Min.	Typ.	Max.	Unit
$V_{CL}$	High Voltage Clamp	$I_C = 6.5 A$ ; (See Note 2)	340	370	400	V
$V_{CE(sat)}$	Saturation Voltage of the Power Stage	$I_C = 5A$ ; $V_{in} = 4V$ (See Note 3)			2	V
$I_{CC(off)}$	Power Off Supply Current	$V_{in}=0.4V$ $V_{bat}= 14V$ (Notes 4-5) $V_{in}=0.4V$ $V_{bat} = 24 V$			20 80	mA mA
$I_{CC(on)}$	Power On Supply Current	$V_{in} = 4 V$ $V_{bat}<14V$ (Note 4-5) $V_{in} = 4 V$ $V_{bat} = 24 V$			220 300	mA mA
$I_{CL}$	Coil Current Limit	$V_{in} = 4 V$ (See Note 6-7)	8		10	A
$V_{inH}$	High Level Input Voltage		4			V
$V_{inL}$	Low Level Input Voltage				0.8	V
$V_{IN(hyst.)}$	Input Hysteresis Voltage		0.4			V
$I_{inH}$	High Level Input Current	$V_{in} = 4 V$	10		150	$\mu A$
$I_{inL}$	Low Level Input Current	$V_{in} = 0.8 V$			-100	$\mu A$
$V_{diagH}$	High Level Diagnostic Output Voltage	$R_{EXT} = 22 K\Omega$ $C_{EXT} = 1 nF$ (See Note 8)	3.5		5.5	V
$V_{diagL}$	Low Level Diagnostic Output Voltage	$R_{EXT} = 22 K\Omega$ $C_{EXT} = 1 nF$ (See Note 8)			0.5	V
$I_{diagTH}$	Current Threshold Level Diagnostic	$T_j = 25^{\circ}C$ (See Note 7 and fig. 5)	4.25	4.5	4.75	A
$I_{diag}$	High Level Flag Output Current	$I_C > I_{DiagTH}$ (See Note 7)	0.5			mA
$I_{diag(leak)}$	Leakage Current on Flag Output	$V_{in} = LOW$			10	$\mu A$
$V_F$	Antiparallel Diode Forward Voltage	$I_C = -1 A$			2	V
$E_{s/b}$	Single Pulse Avalanche Energy		300			mJ
$T_j$	Thermal Output Current Control	IN = ON (See Note 9)	150			$^{\circ}C$
$t_{d(on)}$	Turn-on Delay Time of Output Current	(See Note 10)		TBD		$\mu s$
$t_{d(off)}$	Turn-off Delay Time of Output Current	(See Note 11)		TBD		$\mu s$
$t_{d(off)}$	Turn-off Delay Time of Output Current	(See Note 11)		TBD		$\mu s$

**FIGURE 1:** Temperature Compensated High Voltage Clamp



**FIGURE 2:** Electrical Characteristic of the Circuit Shown in Figure 1



**NOTE 1** Parametric degradation are allowed with  $6V < V_{bat} < 10V$  and  $V_{bat} > 24V$ .

**NOTE 2** In the high voltage clamping structure of this device a temperature compensation has been implemented. The circuit schematic is shown in fig. 1. The KVbe cell takes care of the temperature compensation. The whole electrical characteristic of the new circuit is shown in fig. 2. Up to  $V_{CE}=nV_Z$  no current will flow into the collector (just the leakage current of the power stage); for  $nV_Z < V_{CE} < V_{CL}$  a current begins to flow across the resistances of the KVbe compensation circuit (typical slope  $\cong 20 K\Omega$ ) as soon as the Vcl is reached the dynamic resistance drop to  $\sim 4\Omega$  to protect the device against overvoltage (See Fig. 3).

**NOTE 3** The saturation voltage of the Power stage includes the drop on the sensing resistor.

**NOTE 4** Considering the different ways of operation of the device (with or without spark, etc..) there are some short periods of time in which the output terminal (HVC) is pulled below ground by a negative current due to leakage inductances and stray capacitances of the ignition coil. With VIPower devices, if no corrective action is taken, these negative currents can cause parasitic glitches on the diagnostic output. To kill this potential problem, a circuit that avoids the possibility for the HVC to be pulled underground, by sending the required negative current from the battery is implemented in the VB125SP. For this reason there are some short periods in which a current exceeding 220 mA flows in the pin VD.

**NOTE 5** A zener protection of 16V (typical) is placed on the supply pin ( $V_{CC}$ ) of the chip to protect the internal circuitry. For this reason, when the battery voltage exceeds that value, the current flowing into Vcc pin can be greater than the maximum current specified at  $V_{bat}=14V$  (both in power on and power off conditions) : it will be limited by an internal resistor.

**NOTE 6** The primary coil current value Icl must be measured 1 ms after desaturation of the power stage.

**NOTE 7** These limits apply with regard to the minimum battery voltage and resistive drop on the coil and cables that permit to reach the limitation or diagnostic level.

**NOTE 8** No internal Pull-Down.

**NOTE 9**  $T_{jmin} = 150\text{ }^\circ\text{C}$  means that the behaviour of the device will not be affected for junction temperature lower than  $150\text{ }^\circ\text{C}$ . For higher temperature, the thermal protection circuit will begin its action reducing the Icl limit according with the power dissipation. Chip temperature is a function of the Rth of the whole system in which the device will be operating (See Fig.4).

**NOTE 10** Propagation Time measured from input voltage rising edge to 50% of output voltage falling edge.

**NOTE 11** As soon as the input signal is switched low the stored charges in the base of the power transistor are removed and the so called «Turn-off Delay Time of Coil Current» begins; after at the «Turn-off Fall Time of Coil Current» starts and, at the same time, the HVC rises.

t<sub>dLH</sub> is defined as the time between the negative edge of the input pulse to the point where the HVC reaches 100V.

t<sub>fLH</sub> is defined as the delay between the 90% and the 10% of the coil current.

FIGURE 3:  $V_{cl}$  with load  $L \cong 4 \text{ mH}$

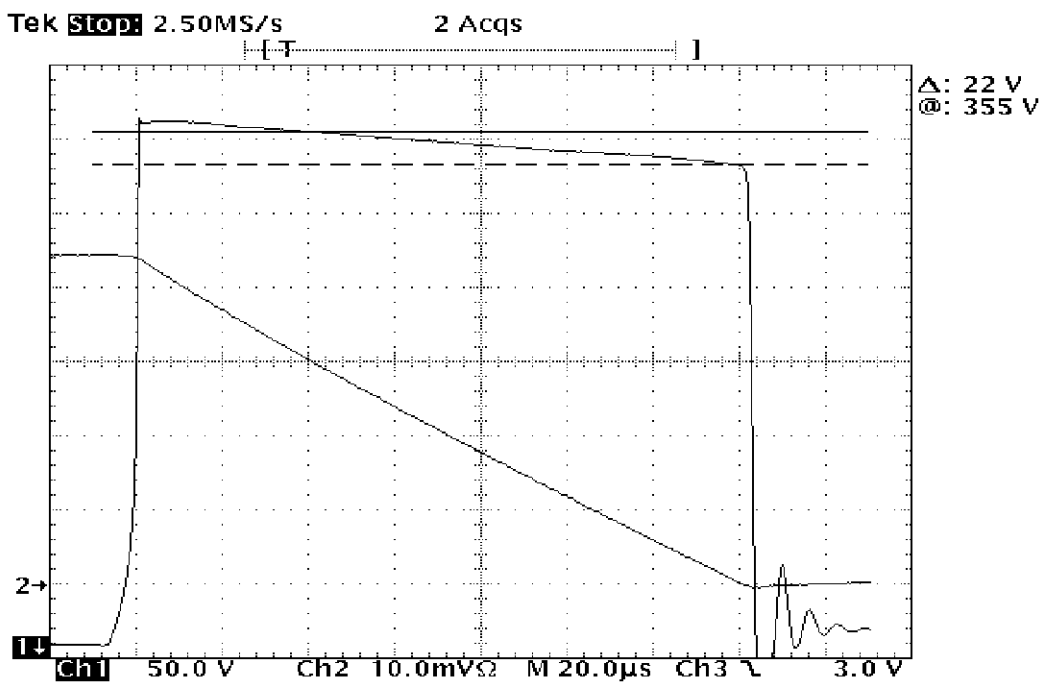
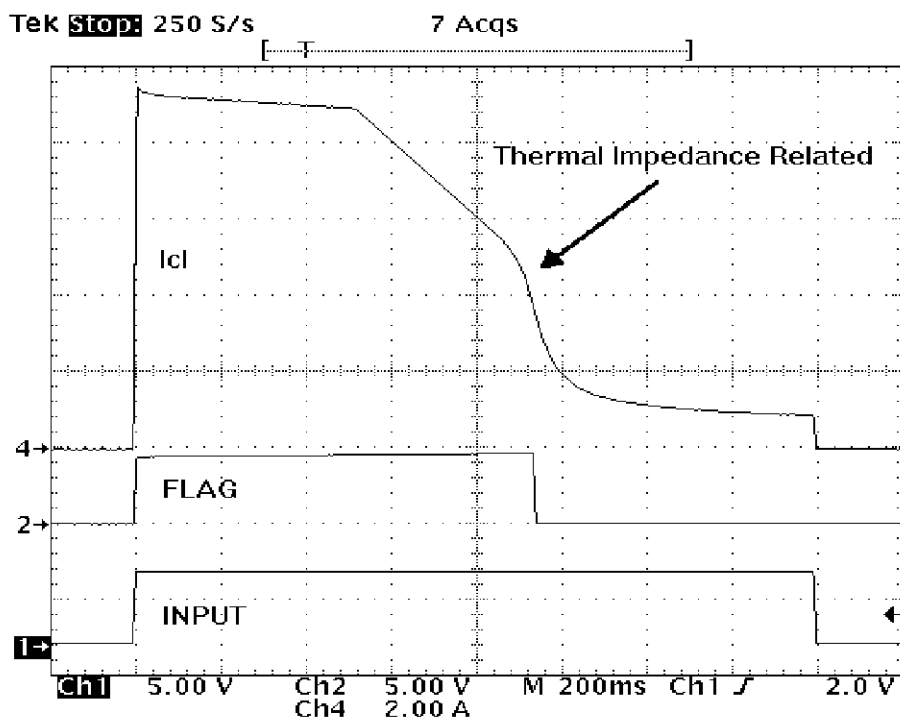
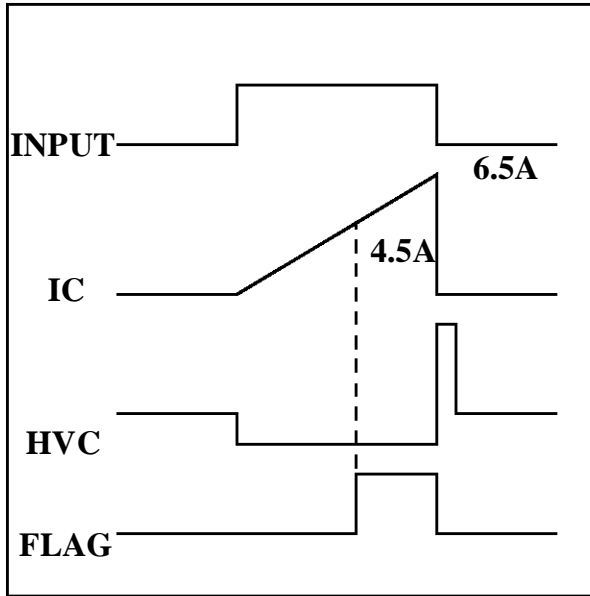


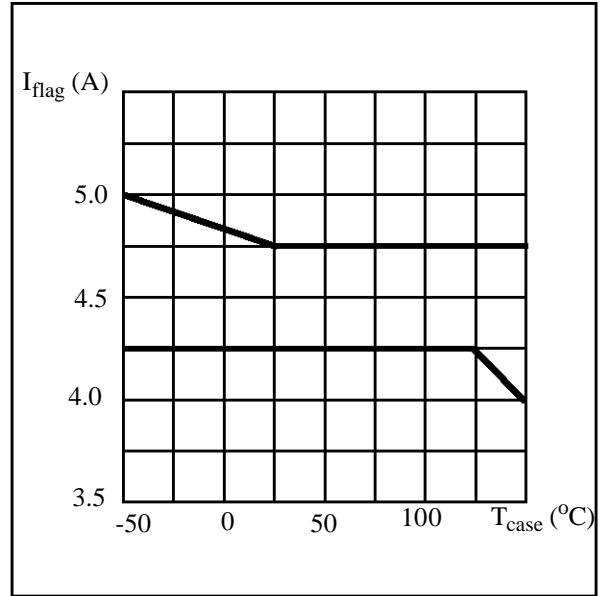
FIGURE 4: Output Current Waveform after Thermal Protection Activation.



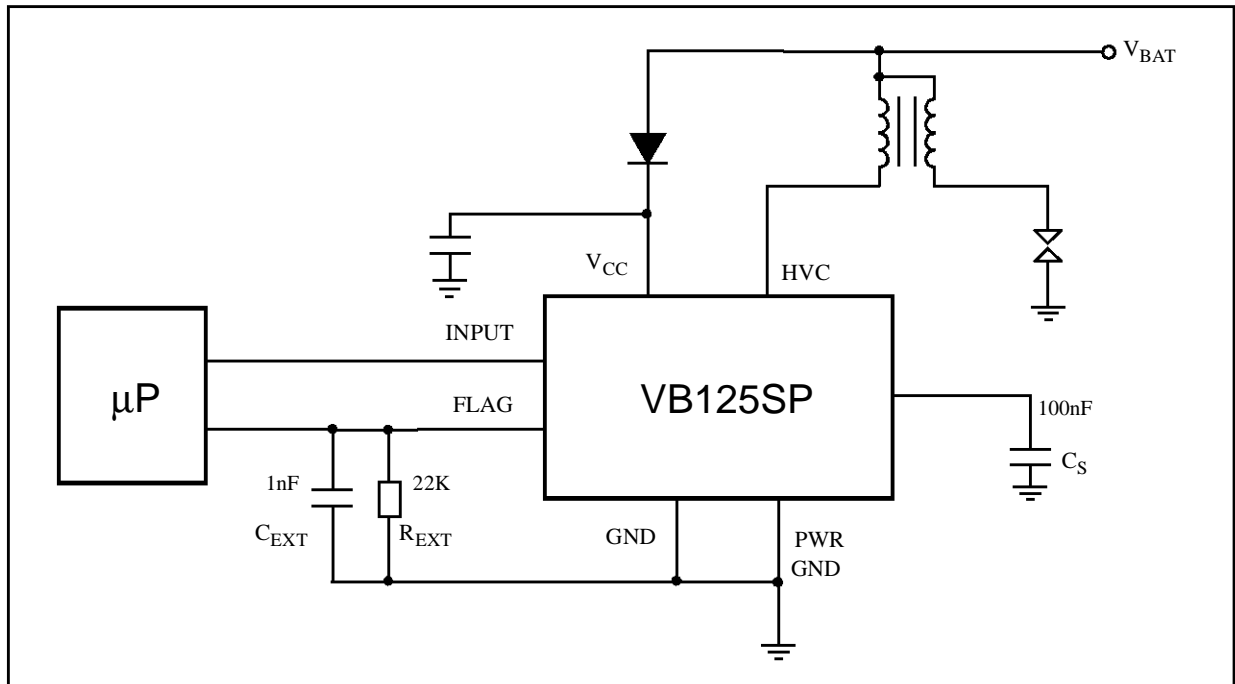
**FIGURE 5: Waveforms**



**FIGURE 6: Flag Current Versus Temperature**

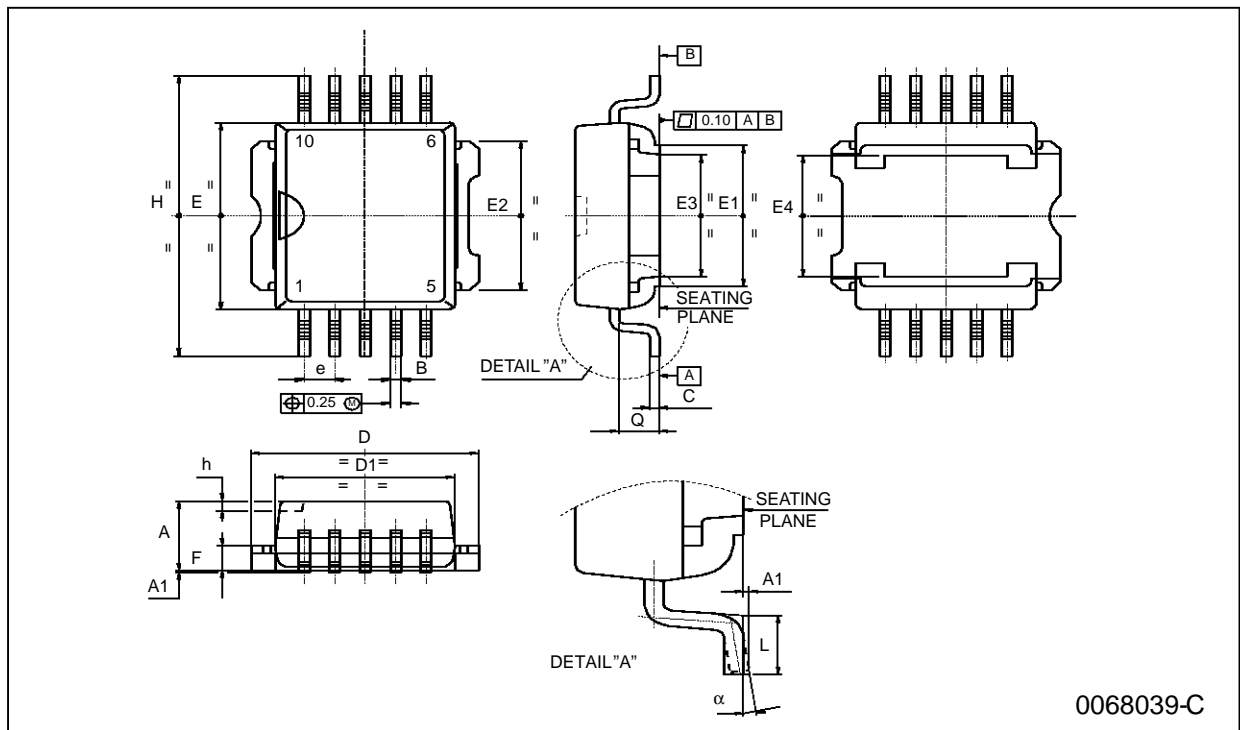


**FIGURE 7: Application Circuit**



**PowerSO-10 MECHANICAL DATA**

DIM.	mm			inch		
	MIN.	TYP.	MAX.	MIN.	TYP.	MAX.
A	3.35		3.65	0.132		0.144
A1	0.00		0.10	0.000		0.004
B	0.40		0.60	0.016		0.024
c	0.35		0.55	0.013		0.022
D	9.40		9.60	0.370		0.378
D1	7.40		7.60	0.291		0.300
E	9.30		9.50	0.366		0.374
E1	7.20		7.40	0.283		0.291
E2	7.20		7.60	0.283		0.300
E3	6.10		6.35	0.240		0.250
E4	5.90		6.10	0.232		0.240
e		1.27			0.050	
F	1.25		1.35	0.049		0.053
H	13.80		14.40	0.543		0.567
h		0.50			0.002	
L	1.20		1.80	0.047		0.071
q		1.70			0.067	



Information furnished is believed to be accurate and reliable. However, SGS-THOMSON Microelectronics assumes no responsibility for the consequences of use of such information nor for any infringement of patents or other rights of third parties which may result from its use. No license is granted by implication or otherwise under any patent or patent rights of SGS-THOMSON Microelectronics. Specifications mentioned in this publication are subject to change without notice. This publication supersedes and replaces all information previously supplied. SGS-THOMSON Microelectronics products are not authorized for use as critical components in life support devices or systems without express written approval of SGS-THOMSON Microelectronics.

© 1997 SGS-THOMSON Microelectronics - Printed in Italy - All Rights Reserved.

SGS-THOMSON Microelectronics GROUP OF COMPANIES

Australia - Brazil - France - Germany - Hong Kong - Italy - Japan - Korea - Malaysia - Malta - Morocco - The Netherlands - Singapore - Spain - Sweden - Switzerland - Taiwan - Thailand - United Kingdom - U.S.A.