

**XFP**  
**850 nm Small Form Factor Module**  
**10 Gigabit Pluggable Transceiver**  
**Compatible with XFP MSA Rev. 3.1**

**V23833-F0005-B101**  
**V23833-F0005-B102**

**Preliminary Data Sheet**

**Features**

**Standards**

- Compatible with IEEE 802.3ae™-2002
- Compatible with Fibre Channel 10GFC Draft 3.5
- Compatible with XFP MSA Rev. 3.1

**Optical**

- IEEE Ethernet: Serial 850 nm 10GBASE-SR
- T11 Fibre Channel: Serial 850 nm  
1200-M5-SN-I; 1200-M5E-SN-I; 1200-M6-SN-I
- Transmission distance
  - up to 82 m<sup>1)</sup> (50 µm MMF)
  - up to 300 m<sup>1)</sup> (on special MMF)
- Vertical Cavity Surface Emitting Laser at 850 nm (VCSEL)
- LC connector, multimode fiber
- Full duplex transmission mode

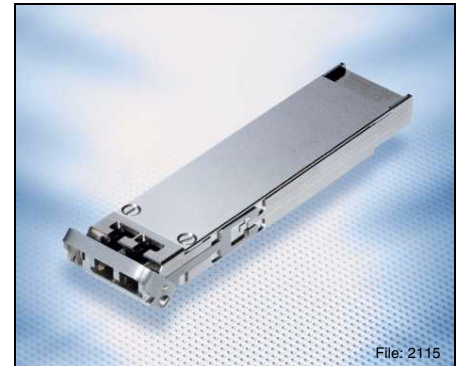

<sup>1)</sup> Maximum reach as defined by IEEE. Longer reach possible depending upon link implementation.

**Ordering Information**

Part Number	Chassis/Signal Grounding Concept	Standard
V23833-F0005-B101	Separated	Multi-Protocol
V23833-F0005-B102	Common	Multi-Protocol

### Monitoring and Control

- Laser safety shut off
- Supply voltage 5 V / 3.3 V
- Transmit power
- Received power RSSI
- Laser bias current
- Tx\_DIS
- Mod\_NR
- Mod\_DeSel
- Interrupt
- Mod\_ABS
- P\_Down/RST
- Rx\_Los

### Mechanical

- Color coded beige for 850 nm
- Belly-to-belly applications
- Latching mechanism with low insertion force

### Electrical

- Hot pluggable
- Power supply 5 V / 3.3 V only
- Total power consumption < 1.5 W max.
- XFI electrical interface
- Reference clock not required
- Management and control via 2-wire interface
- 30 pin connector, 0.8 mm pitch

### Applications

- 10GBE, 10GFC and G.709 transmission systems for short range
- Integration on PCI card, with eventually mid-board mounting
- Belly-to-belly for high density applications
- Enterprise and campus network applications
- Storage applications
- Backplane and switch applications
- Aggregation point for lower data rate
- XFP evaluation kit V23833-F9909-Z001 available upon request

Pin Configuration

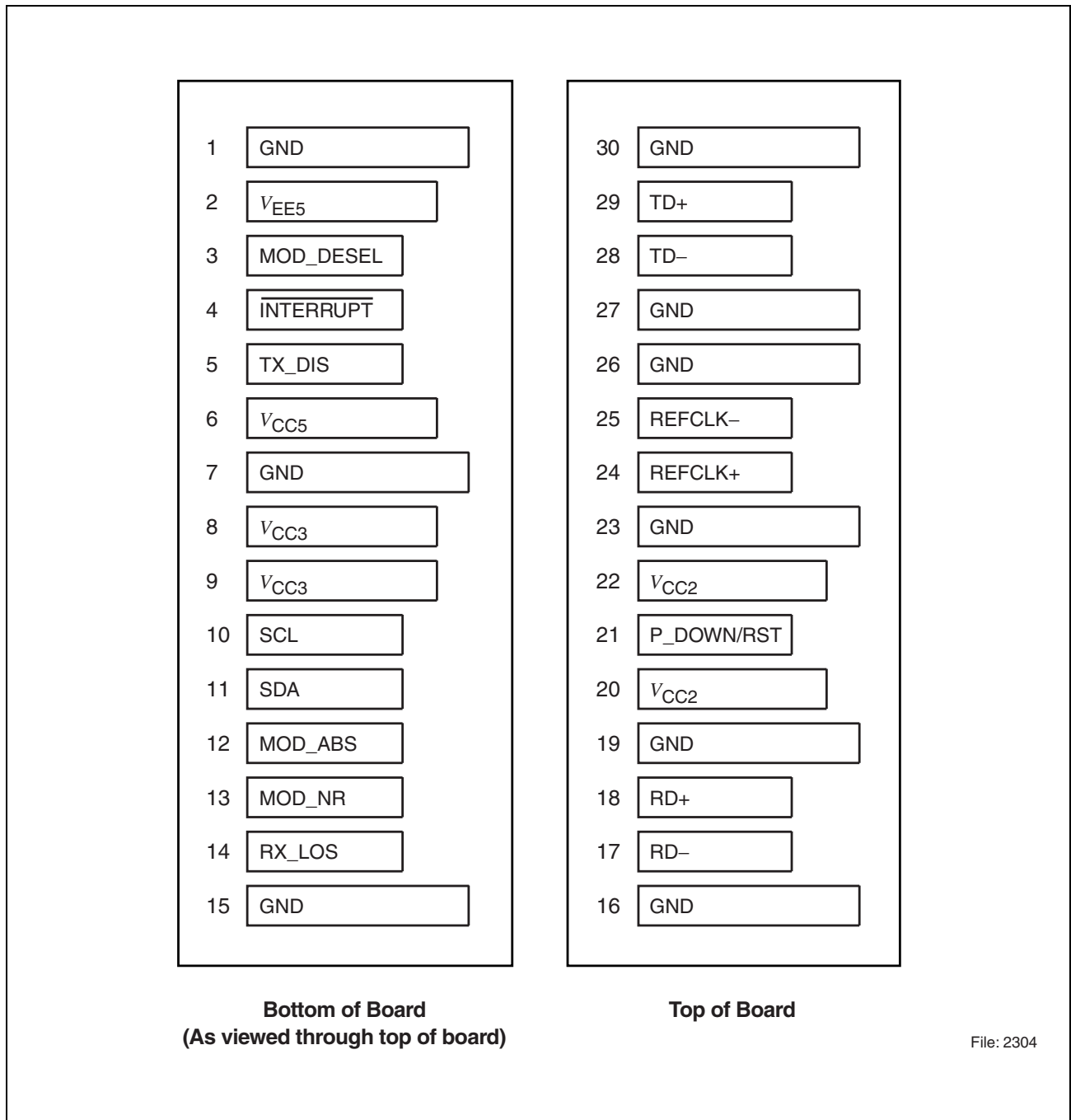

Figure 1 XFP Transceiver Electrical Pad Layout

Pin Configuration

Connector Pin Assignments

Pin No.	Signal Name
1	GND
2	$V_{EE5}$
3	MOD_DESEL
4	INTERRUPT
5	TX_DIS
6	$V_{CC5}$
7	GND
8	$V_{CC3}$
9	$V_{CC3}$
10	SCL
11	SDA
12	MOD_ABS
13	MOD_NR
14	RX_LOS
15	GND

Pin No.	Signal Name
30	GND
29	TD+
28	TD-
27	GND
26	GND
25	REFCLK-
24	REFCLK+
23	GND
22	$V_{CC2}$
21	P_DOWN
20	$V_{CC2}$
19	GND
18	RD+
17	RD-
16	GND

**Pin Configuration**

**Pin Description**

Signal Name	Level	I/O	Pin No.	Description
<b>Management and Monitoring Ports</b>				
MOD_DESEL	LVTTL	I	3	Module De-select: when “L” allows the module to respond to 2-wire serial interface command. “H” active
INTERRUPT	LVTTL	O	4	Interrupt: indicates presence of an important condition which can be read on the 2-wire serial interface. “H” active
TX_DIS	LVTTL	I	5	Transmitter Disable: transmitter laser source is turned off. “H” active
SCL	LVTTL	I	10	2-wire Interface Clock
SDA	LVTTL	I	11	2-wire Interface Data
MOD_ABS	LVTTL	O	12	Module Absent: indicating the modules not present. “H” active
MOD_NR	LVTTL	O	13	Module not ready: module operational fault
RX_LOS	LVTTL	O	14	Receiver Loss Of Signal Indicator
P_DOWN	LVTTL	I	21	Power Saving Mode: places the module in the stand-by condition. Active “H”. During the falling edge set the module reset
<b>Transmit Functions</b>				
TD-	CML	I	28	Transmitter Inverted Data Input
TD+	CML	I	29	Transmitter Not-inverted Data Input
<b>Receive Functions</b>				
RD-	CML	O	17	Receiver Data Output Inverted
RD+	CML	O	18	Receiver Data Output Not-inverted
REFCLK+	PECL	I	24	Reference Clock Not-inverted Input <sup>1)</sup>
REFCLK-	PECL	I	25	Reference Clock Inverted Input <sup>1)</sup>

Pin Configuration

Pin Description (cont'd)

Signal Name	Level	I/O	Pin No.	Description
<b>DC Power</b>				
GND	0 V	–	1,7,15,16,19, 23,26,27,30	Ground connection for both signal and chassis on the module
V <sub>CC5</sub>	+5 V	I	6	Positive power supply, nominal
V <sub>CC3</sub>	+3.3 V	I	8,9	Positive power supply, nominal
V <sub>CC2</sub>	+1.8 V	I	20,22	Positive power supply, nominal

<sup>1)</sup> Reference clock not required. Input internally terminated 50 Ω to ground.

## Description

### System Block Diagram

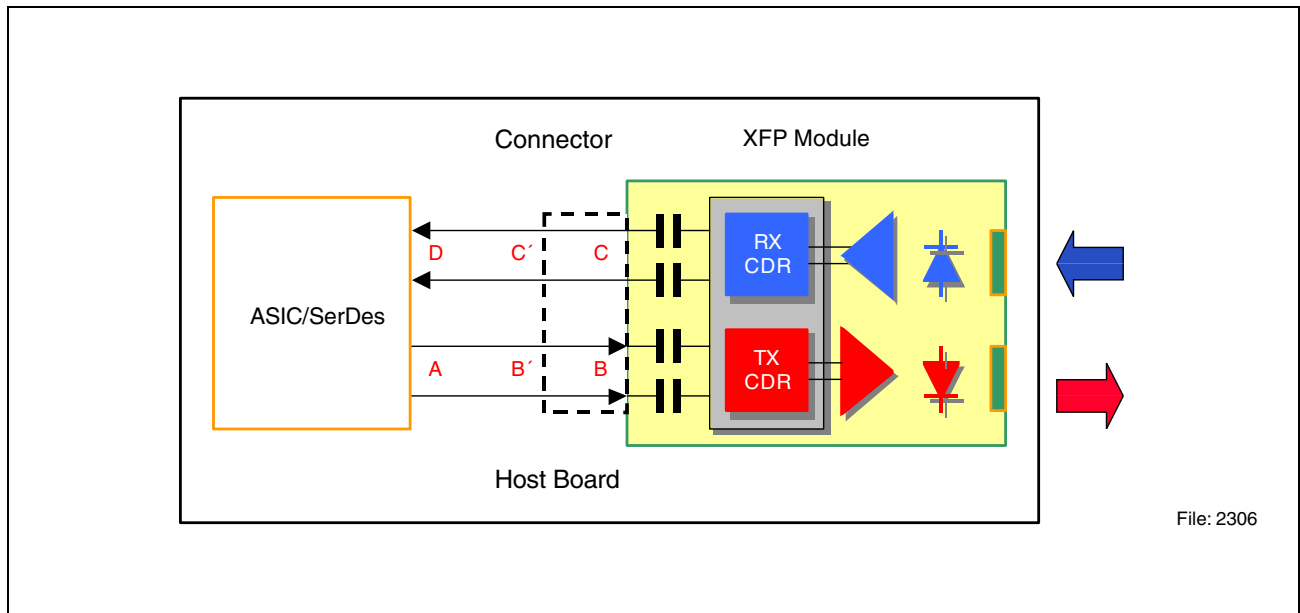

Figure 2

### Optical Interface Standard Specifications

- IEEE 802.3ae™-2002 clause 52, 10GBASE-SR
- Fibre Channel 10GFC Draft 3.5, 1200-M5-SN-I
- Fibre Channel 10GFC Draft 3.5, 1200-M5E-SN-I
- Fibre Channel 10GFC Draft 3.5, 1200-M6-SN-I
- XFP MSA Rev. 3.1

Standard	Fiber Type	Minimum Modal Bandwidth at 850 nm (MHz*km)	Operating Range <sup>1)</sup> (meters)
IEEE	62.5 µm MMF	160	2 to 26
	50 µm MMF	400	2 to 66
Fibre Channel	62.5 µm MMF	200	0.5 to 33
	50 µm MMF	500	0.5 to 82
	50 µm MMF	2000	0.5 to 300

<sup>1)</sup> Longer reaches possible depending upon link implementation.

### Electrical Interface Standard Specifications

- IEEE 802.3ae™-2002 clause 45 & 47
- XFP MSA Rev. 3.1

### Environment: Thermal Management Recommendations

Operating air inlet temperature: 0°C - 50°C  
Operating Airflow: 200 LFM (1.5 m/s)  
Operating Humidity: 80% RH non-condensing  
Maximum operating case temperature is 70°C as defined by UL 1950.

Module can withstand and operate within specification with case temperature of 75°C for up to 96 hrs/yr. Transceiver requires airflow parallel to cooling fins. Maximum airflow required per XFP MSA is 3 m/s.

### Fibers and Connectors

The transceiver LC features a duplex receptacle and is designed for multimode LC cables, 0° polished end face (PC).

### 30-pin Connector

The module interface connector is a 30-pin, printed circuit board edge connection with a 0.8 mm pitch. The appropriate mating connector for the customer PCB is a 30-pin SMT, dual row, right angled, edge connector, 0.8 mm pitch (TycoAmp part number 788862C or equivalent).

### Cage/Heatsink Requirement

The cage/heatsink assembly required to mount the XFP module is defined by the MSA.



**Regulatory Compliance**

Feature	Standard	Comments
ESD: Electrostatic Discharge to the Electrical Pins (HBM)	EIA/JESD22-A114-B (MIL-STD 883D Method 3015.7)	Class 1a (> 500 V)
Immunity: Against Electrostatic Discharge (ESD) to the Module Receptacle	EN 61000-4-2 IEC 61000-4-2	Discharges ranging from $\pm 2$ kV to $\pm 25$ kV to the front end / faceplate / receptacle cause no damage to module (under recommended conditions).
Immunity: Against Radio Frequency Electromagnetic Field	EN 61000-4-3 IEC 61000-4-3	With a field strength of 30 V/m, noise frequency ranges from 10 MHz to 2 GHz. No effect on module performance between the specification limits.
Emission: Electromagnetic Interference (EMI)	FCC 47 CFR Part 15, Class B EN 55022 Class B CISPR 22	Noise frequency range: 30 MHz to 40 GHz Radiated emission does not exceed specified limits.

## Technical Data

### Absolute Maximum Ratings

Parameter	Symbol	Limit Values		Unit
		min.	max.	
Storage Ambient Temperature <sup>1)</sup>	$T_S$	-20	85	°C
Operating Ambient Temperature <sup>1) 2)</sup>	$T_A$	0	50	°C
Operating Case Temperature <sup>1)</sup>	$T_C$	0	80	°C
Supply Voltage +5.0 V	$V_5$	0	6	V
Supply Voltage +3.3 V	$V_3$	0	4	V
Static Discharge Voltage, All Pins	$ST_d$	-500	500	V
Average Receive Optical Power	$Rx_{P_{max}}$		1.5	dBm

<sup>1)</sup> Non condensing.

<sup>2)</sup> With specified airflow (see "Environment: Thermal Management Recommendations").

Exceeding any one of these values may permanently destroy the device.

### Recommended Operating Conditions

Parameter	Symbol	Values			Unit
		min.	typ.	max.	
Operating Case Temperature <sup>1)</sup>	$T_C$	0		70	°C
Transceiver Total Power Consumption	$P$		1.25		W
Supply Voltage +5.0 V	$V_{CC5}$	4.75	5.0	5.25	V
Supply Current +5.0 V	$I_{CC5}$		50		mA
Supply Voltage +3.3 V	$V_{CC3}$	3.14	3.3	3.47	V
Supply Current +3.3 V	$I_{CC3}$		300		mA

<sup>1)</sup> Worst case thermal location (see **Figure 15**).

**Optical Characteristics**
 $(V_{CC5} = 4.75 \text{ V to } 5.25 \text{ V}, V_{CC3} = 3.14 \text{ V to } 3.47 \text{ V}, T_C = 0^\circ\text{C to } 70^\circ\text{C})$ 

Parameter	Symbol	Values			Unit
		min.	typ.	max.	
<b>Transmitter</b>					
Launch Power in OMA <sup>1)</sup>	$P_{O-OMA}$	-2.8			dBm
Average Launch Power	$P_{O-Avg}$	-3	-2	-1	dBm
Center Wavelength Range <sup>1)</sup>	$\lambda_{C-Tx}$	840	850	860	nm
RMS Spectral Width <sup>1)</sup>	$\sigma_I$		0.4	0.45	nm
Extinction Ratio	ER	3	5.5		dB
Relative Intensity Noise <sub>12</sub> OMA	RIN			-128	dB/Hz
Eye Mask Definition	According to IEEE and Fibre Channel				
Transmitter and Dispersion Penalty	TDP			3.9	dB
Encircled Flux	EF	at 19 $\mu\text{m} \geq 86\%$ , at 4.5 $\mu\text{m} \leq 30\%$			
Optical Return Loss Tolerance	ORL <sub>T</sub>			12	dB
Average Launch Power of OFF Transmitter	$P_{O-OFF}$			-30	dBm
<b>Receiver</b>					
Stressed Receiver Sensitivity in OMA	$P_{IN-S}$			-7.5	dBm
Sensitivity in OMA <sup>2)</sup>	$P_{IN}$			-11.1	dBm
Average Receive Power	$P_{IN-max}$			-1	dBm
Signal Detect Deassert Level	$P_{SDL}$	-30			dBm
Signal Detect Assert Level	$P_{SD}$		-20	-13	dBm
Signal Detect Hysteresis	$P_{SD}$	1	2	4	dB
Receiver Reflectance	REF <sub>Rx</sub>			-12	dB
Center Wavelength Range	$\lambda_{C-Rx}$	840		860	nm

<sup>1)</sup> Conforms to IEEE triple trade off between center wavelength, RMS spectral width and minimum OMA.

<sup>2)</sup> Receiver sensitivity, which is defined for an ideal input signal is informative only.

**Electrical DC Characteristics**

( $V_{CC5} = 4.75\text{ V to }5.25\text{ V}$ ,  $V_{CC3} = 3.14\text{ V to }3.47\text{ V}$ ,  $T_C = 0^\circ\text{C to }70^\circ\text{C}$ )

Parameter	Symbol	Values			Unit
		min.	typ.	max.	

**3.3 V CMOS I/O DC Characteristics  
(Management, Logic and Monitoring Ports)**

External Pull-up Resistor for Open Drain	$R_{\text{pullup}}$	10		22	k $\Omega$
Output High Voltage <sup>1)</sup>	$V_{\text{oh}}$	2.4		3.5	V
Output Low Voltage <sup>1)</sup>	$V_{\text{ol}}$			0.4	V
Input High Voltage	$V_{\text{ih}}$			2	V
Input Low Voltage	$V_{\text{il}}$	0		0.8	V
Input Pull-up Current <sup>2)</sup>	$I_{\text{pd}}$	-10	0	10	$\mu\text{A}$

**LVPECL I/O Characteristics  
(REFCLK+/-)**

Differential Input Voltage (pk-pk) <sup>3)</sup>	$V_{\text{in\_diff}}$	400		2000	mV p-p
--	-----------------------	-----	--	------	-----------

**XFI I/O DC Characteristics  
(TD+/-; RD+/-)**

Differential Input Amplitude (pk-pk) <sup>4)</sup>	TD+/-	240		1640	mV p-p diff
Differential Output Amplitude (pk-pk) <sup>5)</sup>	RD+/-	680		1700	mV p-p diff

<sup>1)</sup>  $R_{\text{pull-up}} = 10\text{ k}\Omega\text{ to }3.3\text{ V}$ .

<sup>2)</sup>  $V_{\text{in}} = 3.3\text{ V}$ .

<sup>3)</sup> AC coupled in transceiver.

<sup>4)</sup> AC coupled input at host board.

<sup>5)</sup> AC coupled output at host board.

**Electrical AC Characteristics**
 $(V_{CC5} = 4.75 \text{ V to } 5.25 \text{ V}, V_{CC3} = 3.14 \text{ V to } 3.47 \text{ V}, T_C = 0^\circ\text{C to } 70^\circ\text{C})$ 

Parameter	Symbol	Values			Unit
		min.	typ.	max.	

**XFI Input AC Characteristics  
(TD+/-)**

Baud Rate	TD+/-	9.95	10.3125	10.75	Gbit/s
Baud Rate Tolerance	TD <sub>tol</sub>	-500		500	ppm
Differential Input Impedance	Z <sub>IN</sub>	80	100	120	Ω
Differential Return Loss <sup>1)</sup>	S <sub>11</sub>	8			dB
Input Differential Skew <sup>2)</sup>	T <sub>SKEWIN</sub>		t.b.d.		ps
Total Jitter <sup>3)</sup>	TJ <sub>TD</sub>			0.61	UI pp
Deterministic Jitter <sup>3)</sup>	TJ <sub>TD</sub>			0.2	UI pp

**XFI Output AC Characteristics  
(RD+/-)**

Baud Rate	RD+/-	9.95	10.3125	10.75	Gbit/s
Baud Rate Tolerance	RD <sub>tol</sub>	-100		100	ppm
Rise and Fall Times <sup>4)</sup>	t <sub>r</sub> , t <sub>f</sub>	24			ps
Output Differential Skew	T <sub>SKEWOUT</sub>		t.b.d.		ps
Output Differential Impedance	Z <sub>OUT</sub>	80	100	120	Ω
Differential Output Return Loss <sup>1)</sup>	S <sub>22</sub>	8			dB
Total Jitter <sup>5)</sup>	TJ <sub>RD</sub>			0.34	UI
Deterministic Jitter <sup>5)</sup>	DJ <sub>RD</sub>			0.18	UI

**Electrical AC Characteristics (cont'd)**

( $V_{CC5} = 4.75\text{ V to }5.25\text{ V}$ ,  $V_{CC3} = 3.14\text{ V to }3.47\text{ V}$ ,  $T_C = 0^\circ\text{C to }70^\circ\text{C}$ )

Parameter	Symbol	Values			Unit
		min.	typ.	max.	

**3.3 V CMOS I/O AC Characteristics for I<sup>2</sup>C Signals (SDA; SCL)**

SCL Clock Frequency	$f_{SCL}$	0		400	kHz
SCL Period Low	$t_{LOW}$	1.3			$\mu\text{s}$
SCL Period High	$t_{HIGH}$	0.6			$\mu\text{s}$
Bus Free Time <sup>6)</sup>	$t_{BUF}$	1.3			$\mu\text{s}$
Start Condition Setup Time	$t_{SU\_START}$	0.6			$\mu\text{s}$
Stop Condition Setup Time	$t_{SU\_STOP}$	0.6			$\mu\text{s}$
Start Condition Hold Time	$t_{H\_START}$	0.6			$\mu\text{s}$
Data Hold Time	$t_{H\_DATA}$	0			$\mu\text{s}$
Data Setup Time	$t_{SU\_DATA}$	100			ns
SDA and SCL Rise and Fall Time	$t_r, t_f$			300	ns

<sup>1)</sup> 100 MHz - 5.5 GHz above 5.5 GHz see XFP MSA 3.1.

<sup>2)</sup> Not defined at crossing point.

<sup>3)</sup> Per XFP MSA 3.1 table 17, 1 UI = 96.97 ps.

<sup>4)</sup> 20%, 80%.

<sup>5)</sup> Per XFP MSA 3.1 table 19, 1 UI = 96.97 ps.

<sup>6)</sup> Between stop and start condition.

### Timing Parameters for XFP Management

Parameter	Symbol	Values		Unit
		min.	max.	
TX_DIS Assert Time <sup>1)</sup>	t_off		10	μs
TX_DIS Negate Time <sup>2)</sup>	t_on		2	ms
Time to Initialize <sup>3)</sup>	t_init		300	ms
INTERRUPT Assert Delay <sup>4)</sup>	Interrupt_on		200	ms
INTERRUPT Negate Delay <sup>5)</sup>	Interrupt_off		500	μs
P_DOWN/RST Assert Delay <sup>6)</sup>	P_Down/RST_on		100	μs
MOD_NR Assert Delay <sup>7)</sup>	Mod_nr_on		1	ms
MOD_NR Negate Delay <sup>8)</sup>	Mod_nr_off		1	ms
P_DOWN Reset Time <sup>9)</sup>		10		μs
RX_LOS Assert Delay <sup>10)</sup>	t_loss_on		100	μs
RX_LOS Negate Delay <sup>11)</sup>	t_loss_off		100	μs

- <sup>1)</sup> Rising edge of TX\_DIS to fall of output signal below 10% of nominal.  
<sup>2)</sup> Falling edge of TX\_DIS to rise of output signal above 90% of nominal.  
<sup>3)</sup> From power on or hot plug after supply or from falling edge of P\_DOWN/RST.  
<sup>4)</sup> From occurrence of the condition triggering INTERRUPT.  
<sup>5)</sup> From clear on read INTERRUPT flags.  
<sup>6)</sup> From power down initiation.  
<sup>7)</sup> From occurrence of fault to assertion of MOD\_NR.  
<sup>8)</sup> From clearance of signal to negation of MOD\_NR.  
<sup>9)</sup> Min. length of P\_DOWN assert to initiate reset.  
<sup>10)</sup> From occurrence of loss of signal to assertion of RX\_LOS.  
<sup>11)</sup> From occurrence of presence of signal to negation of RX\_LOS.

## Eye Safety

This laser based multimode transceiver is a Class 1M product. It complies with IEC 60825-1/A2: 2001 and FDA performance standards for laser products (21 CFR 1040.10 and 1040.11) except for deviations pursuant to Laser Notice 50, dated July 26, 2001.

**INVISIBLE LASER RADIATION  
CLASS 1M LASER PRODUCT  
DO NOT VIEW DIRECTLY WITH OPTICAL INSTRUMENTS**

To meet laser safety requirements the transceiver shall be operated within the Absolute Maximum Ratings.

*Note: All adjustments have been made at the factory prior to shipment of the devices. No maintenance or alteration to the device is required. Tampering with or modifying the performance of the device will result in voided product warranty. Failure to adhere to the above restrictions could result in a modification that is considered an act of “manufacturing”, and will require, under law, recertification of the modified product with the U.S. Food and Drug Administration (ref. 21 CFR 1040.10 (i)).*

## Laser Emission Data

Wavelength	850 nm
Maximum total output power (as defined by IEC: 7 mm aperture at 100 mm distance)	743 $\mu$ W / -1.3 dBm
Beam divergence (full angle) / NA (half angle)	20° / 0.18 rad

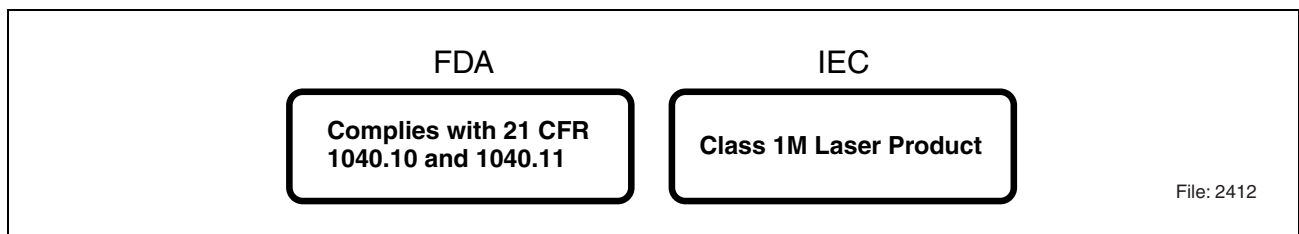

**Figure 3 Required Labels**

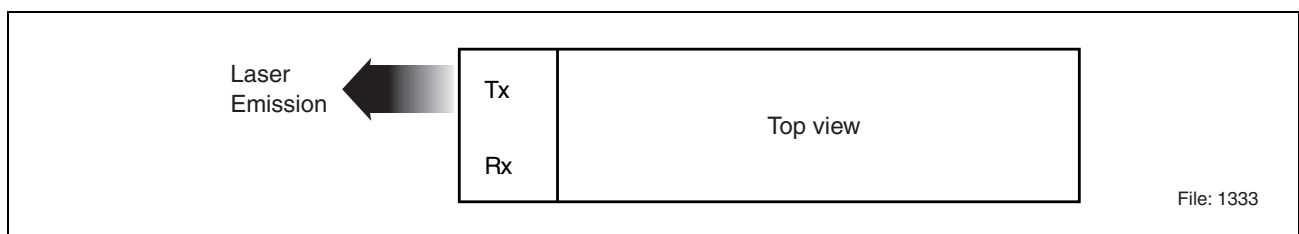

**Figure 4 Laser Emission**



## Application Notes

### Host Board Layouts

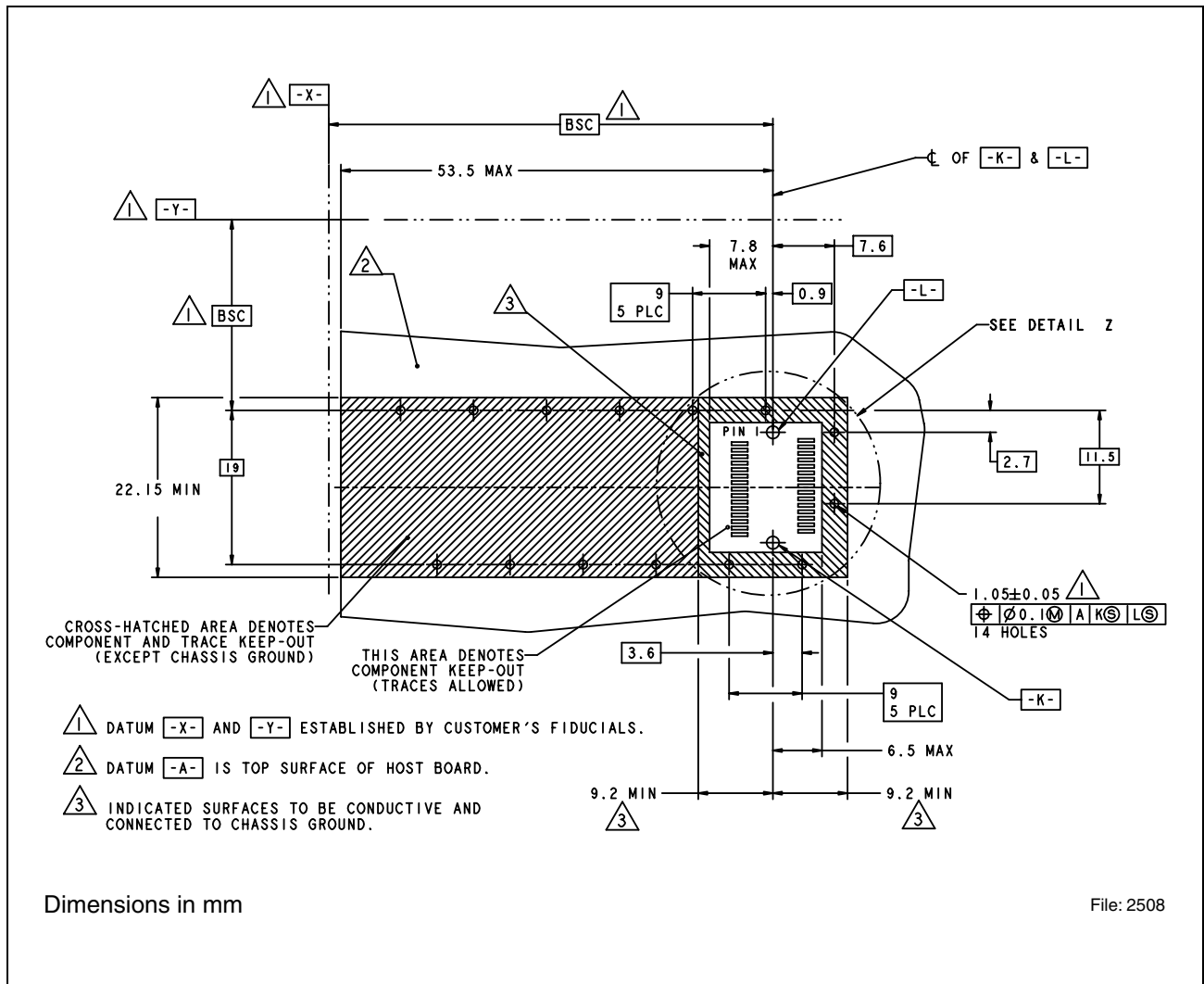

Figure 5 XFP Host Board Mechanical Layout

Detail Z see Figure 6.

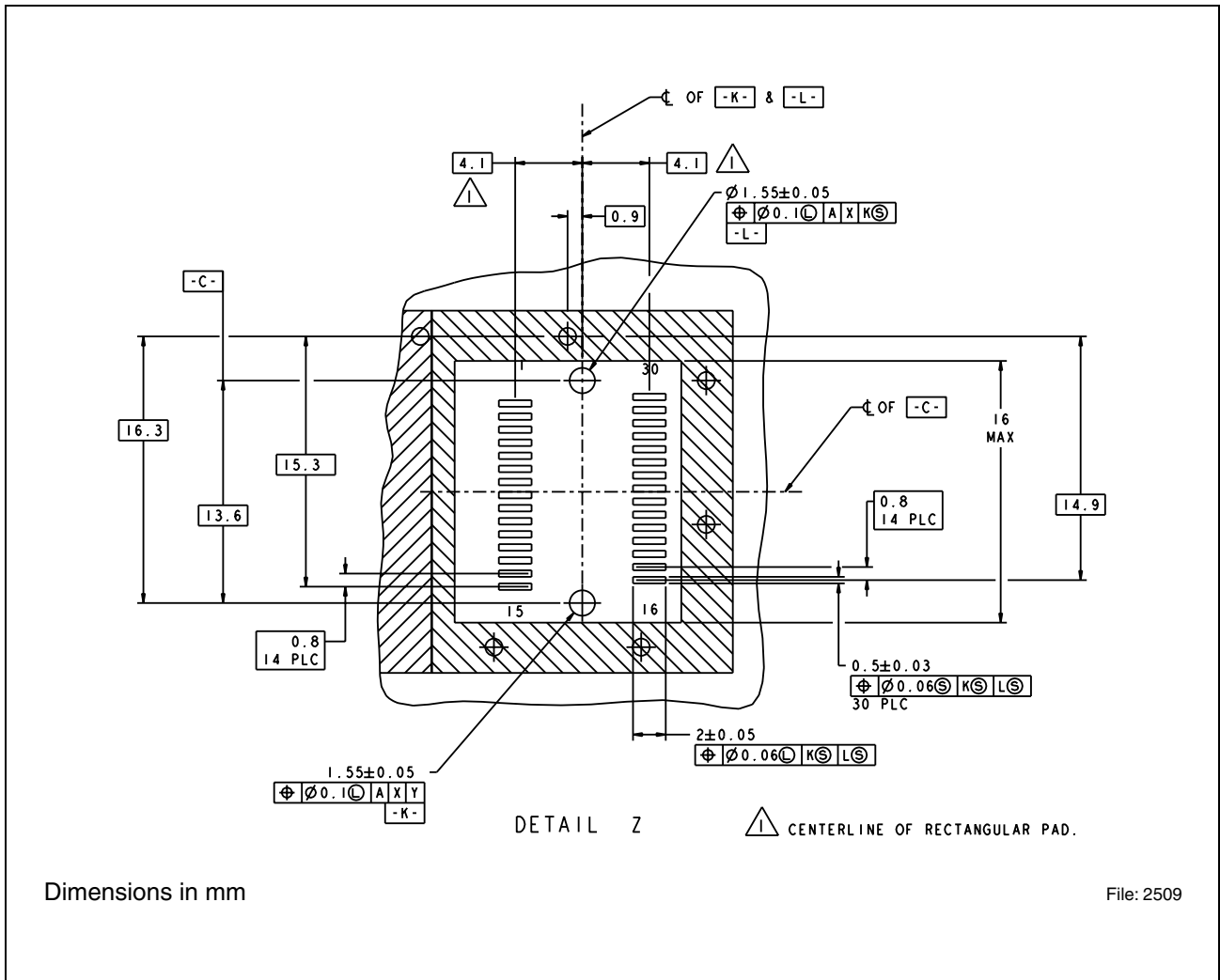
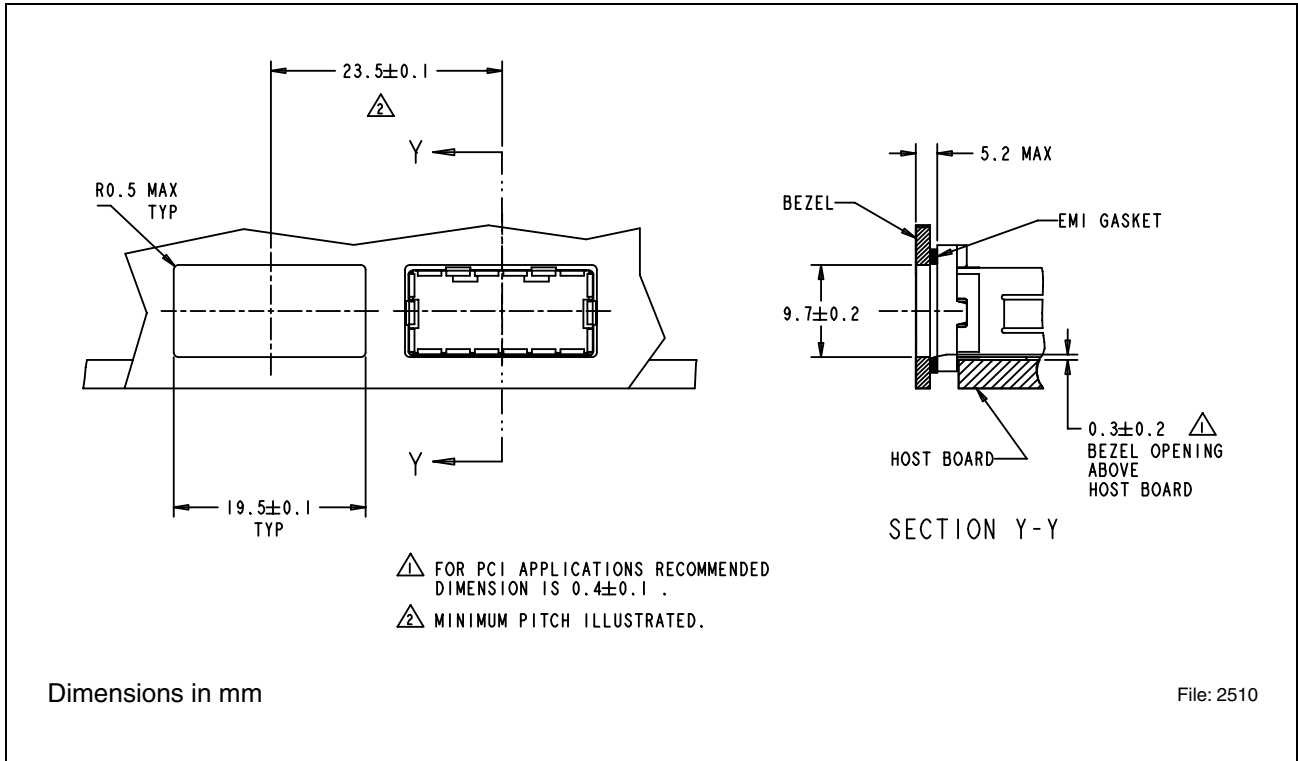
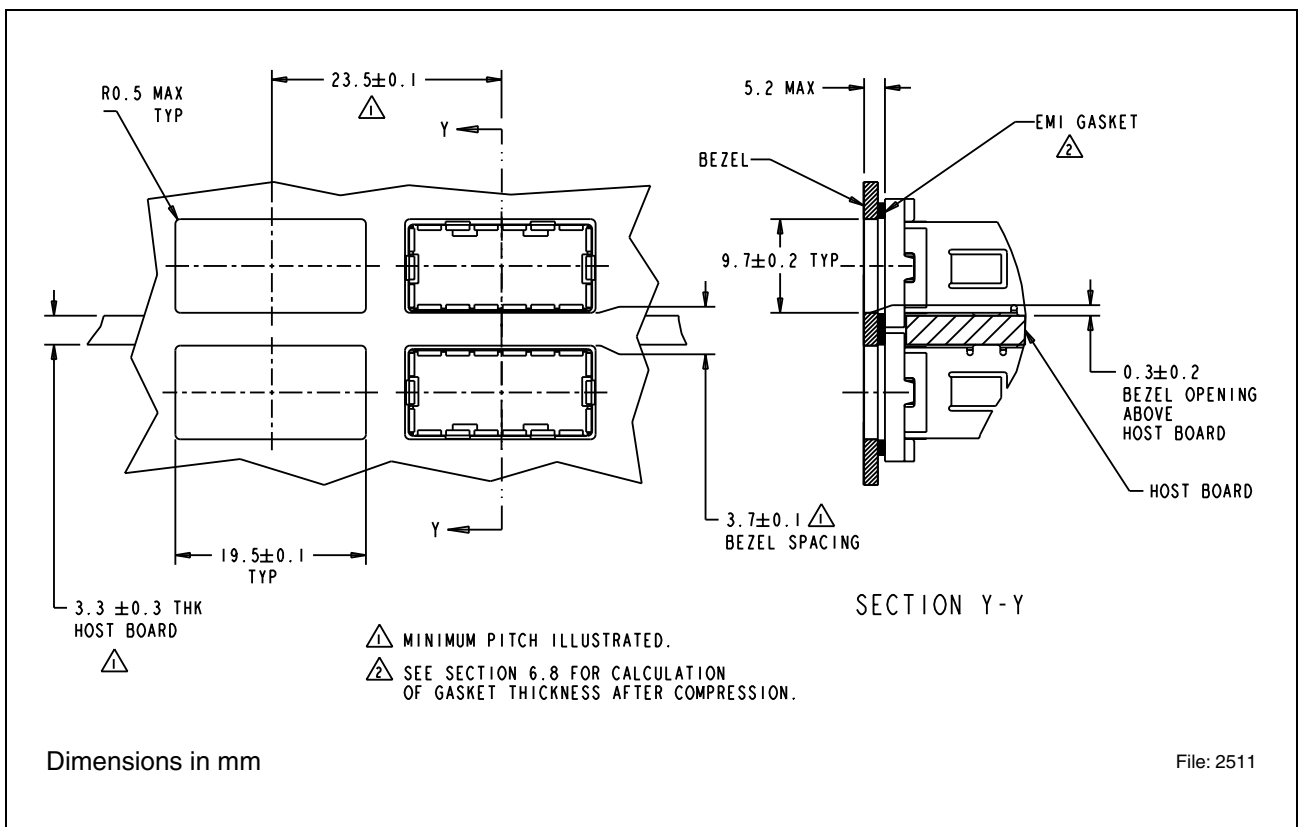

Figure 6 XFP Host Board Mechanical Layout, Detail Z

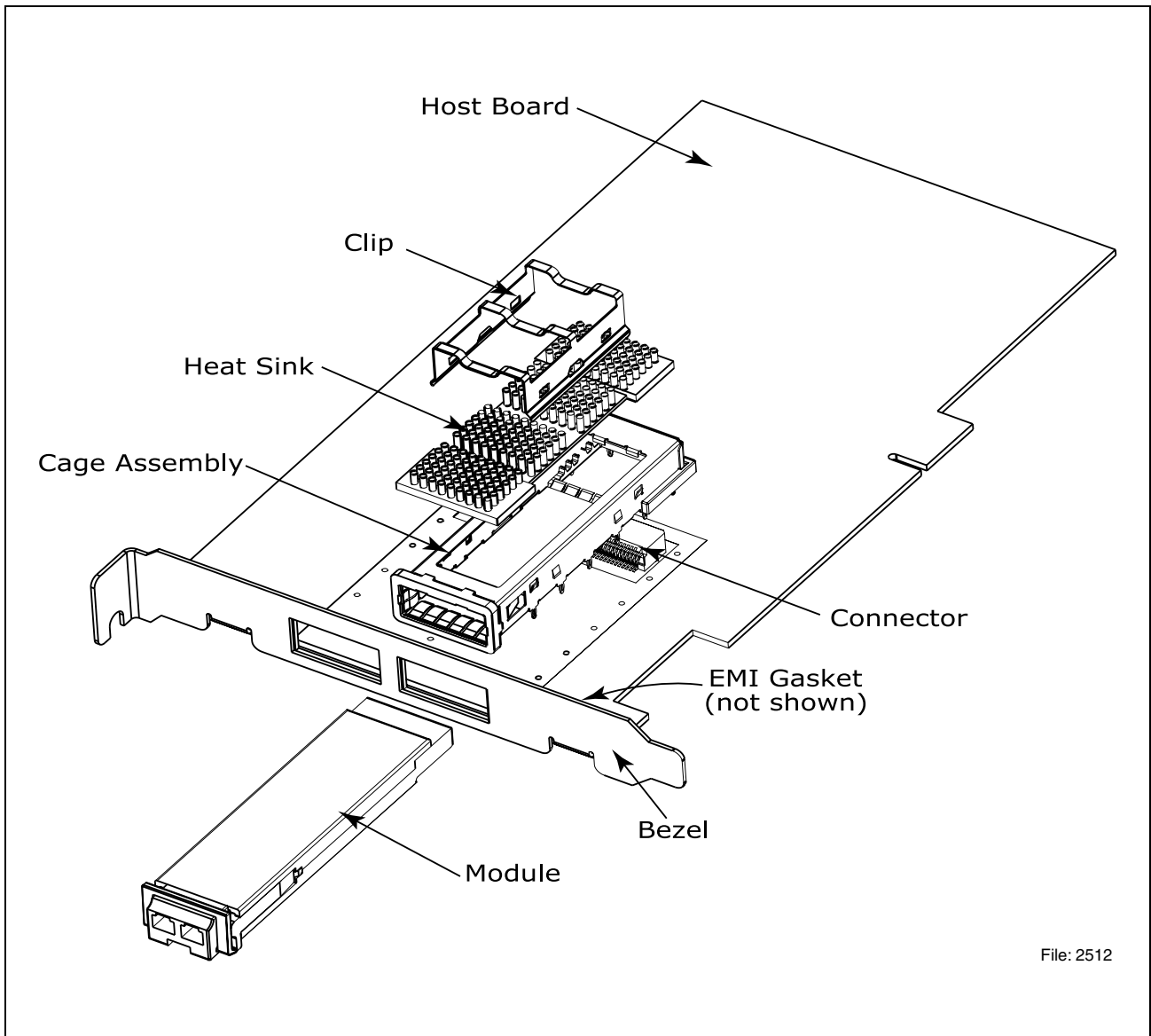

**Figure 7 Recommended Single Sided Bezel Design**



**Figure 8 Recommended Double Sided Mounting Bezel Design**

## Mechanical



**Figure 9** PCI Card Application

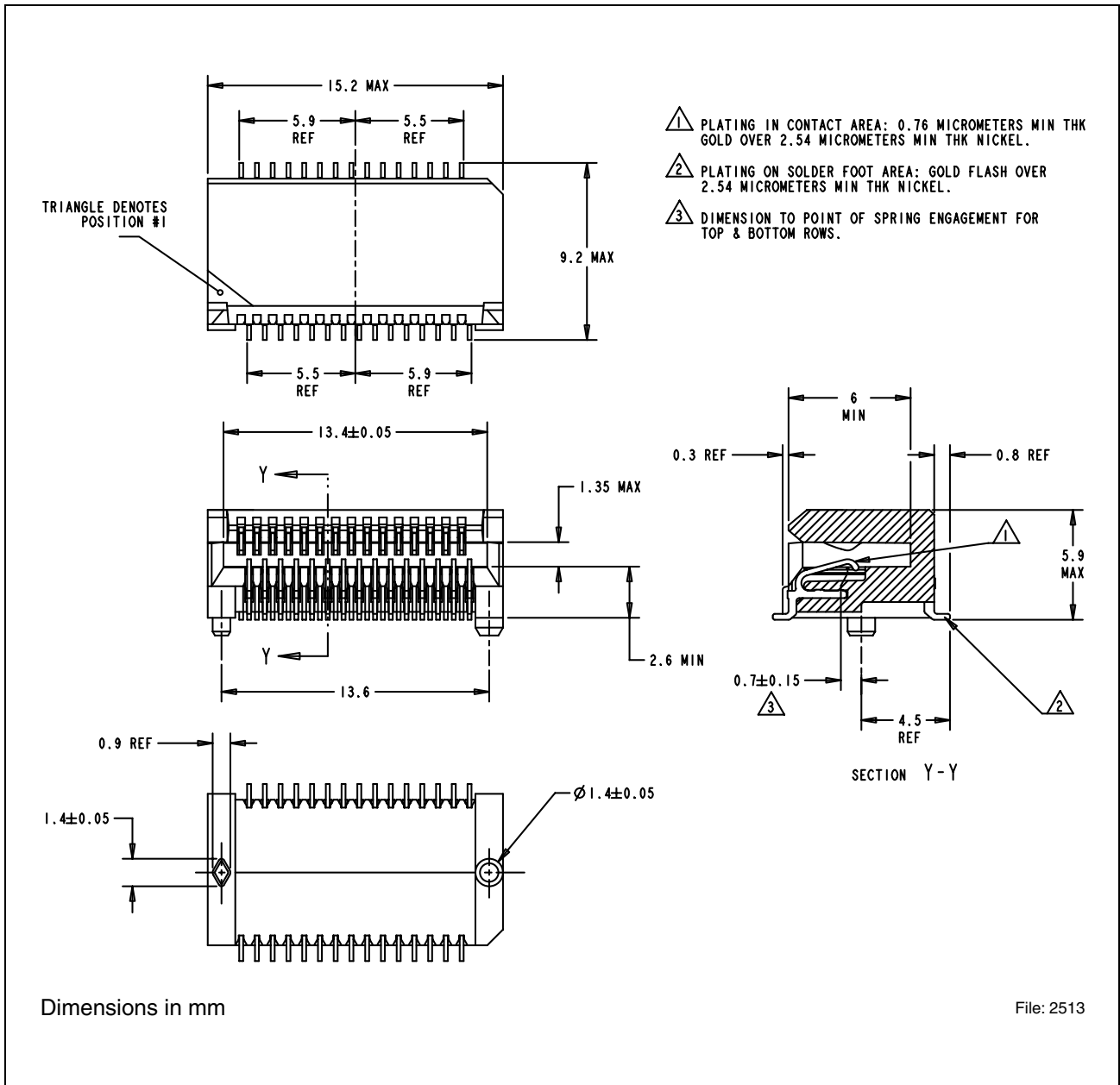

Figure 10 XFP Transceiver Connector Illustration

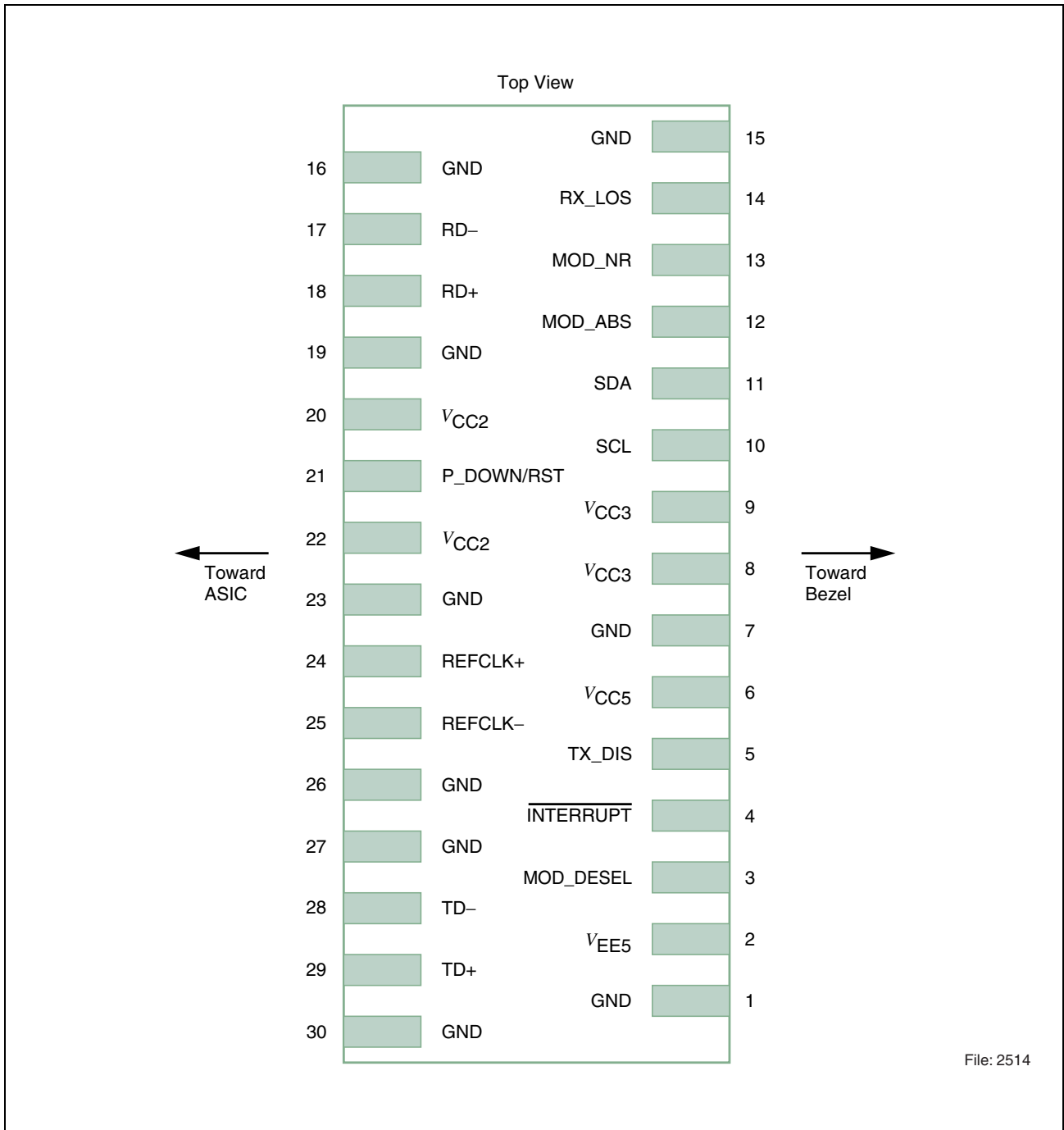
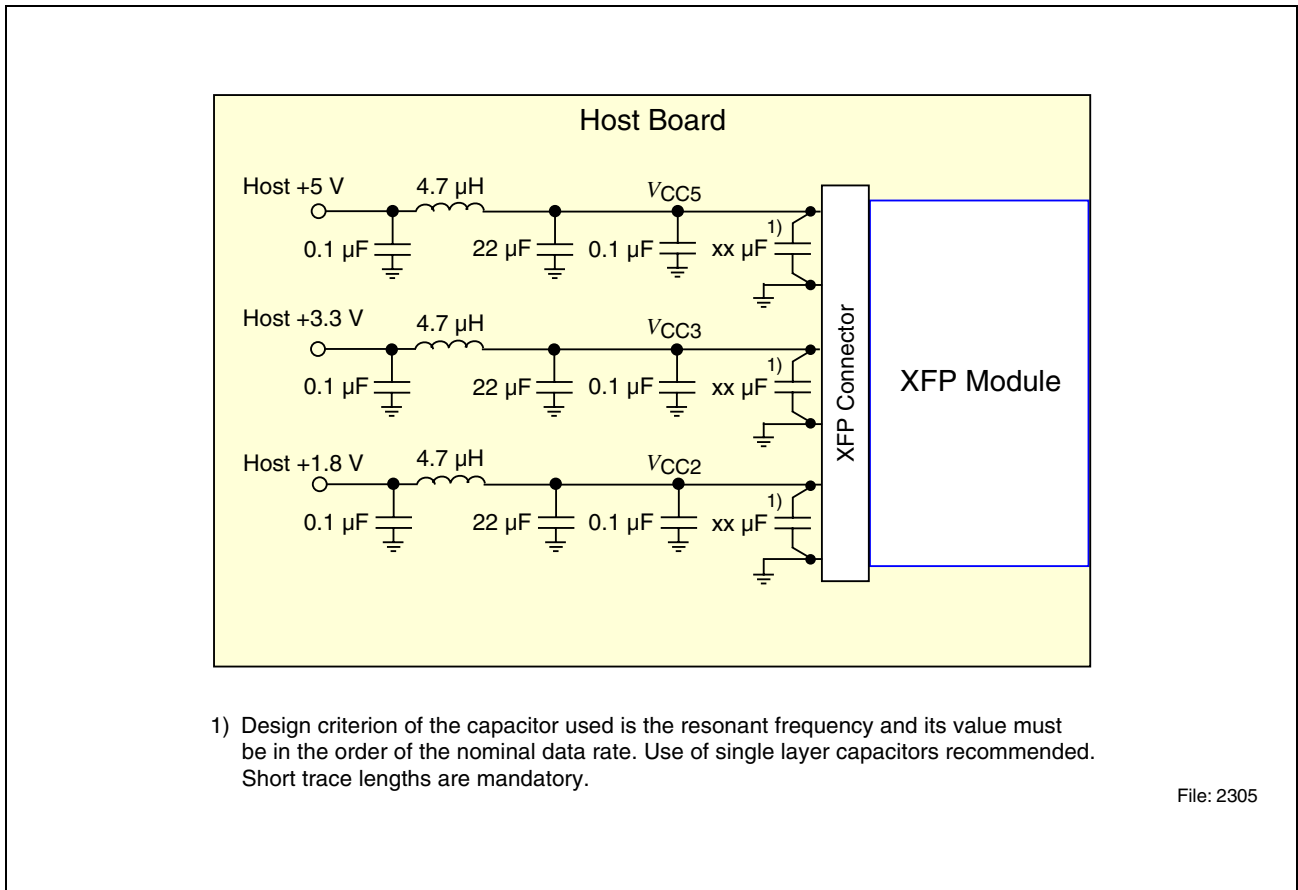

Figure 11 Host PCB XFP Pinout



**Figure 12 Recommended Host Board Supply Filtering Network**

Package Outlines

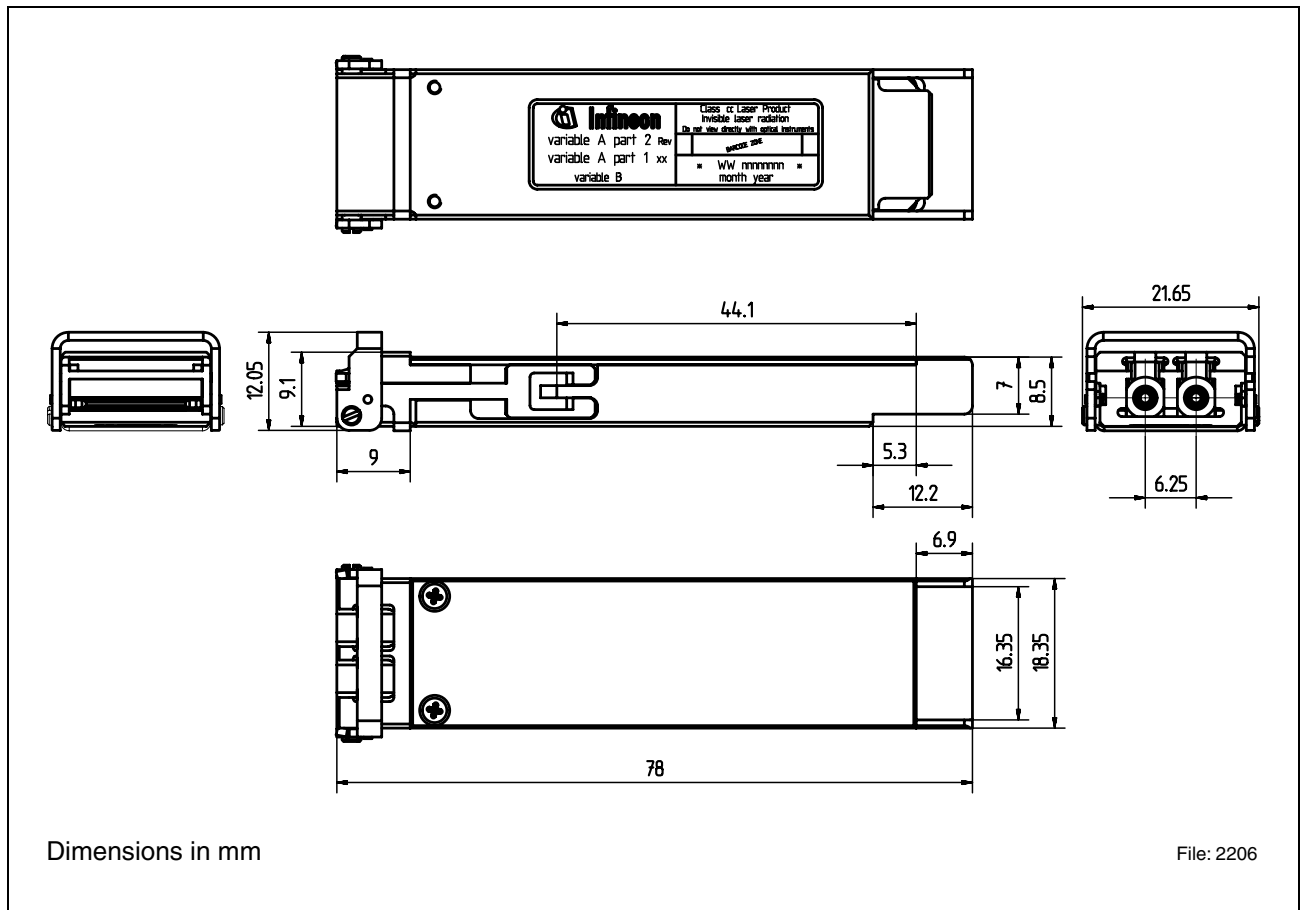

Figure 13 Mechanical Dimensions

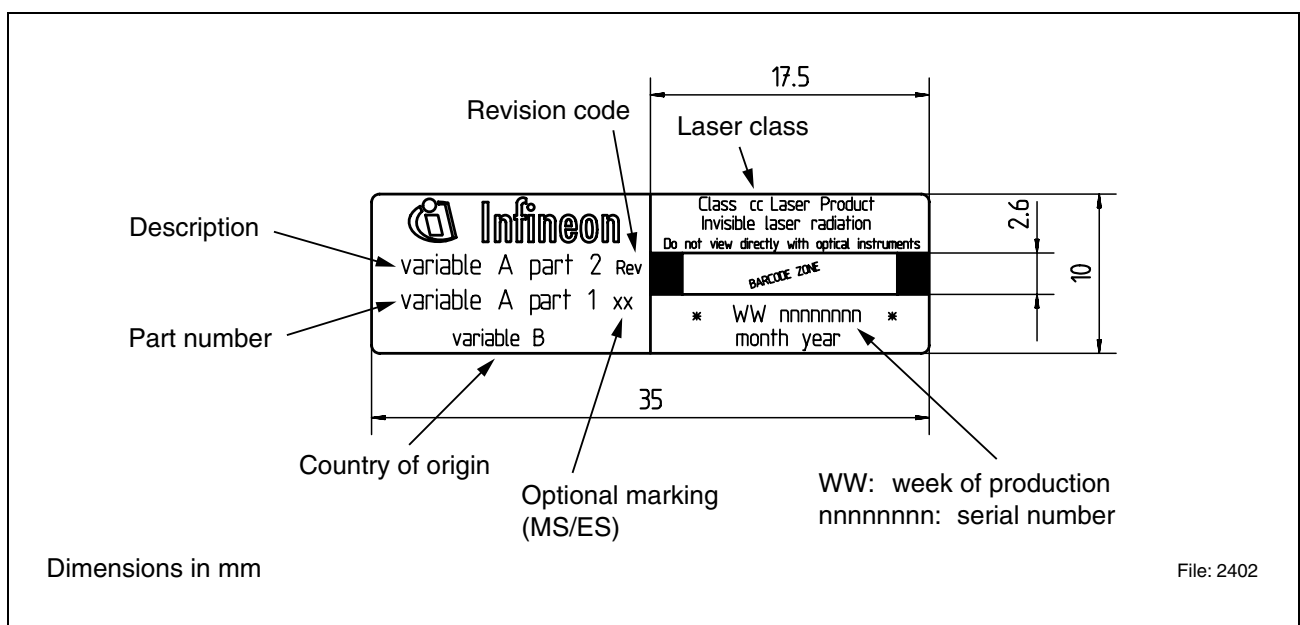
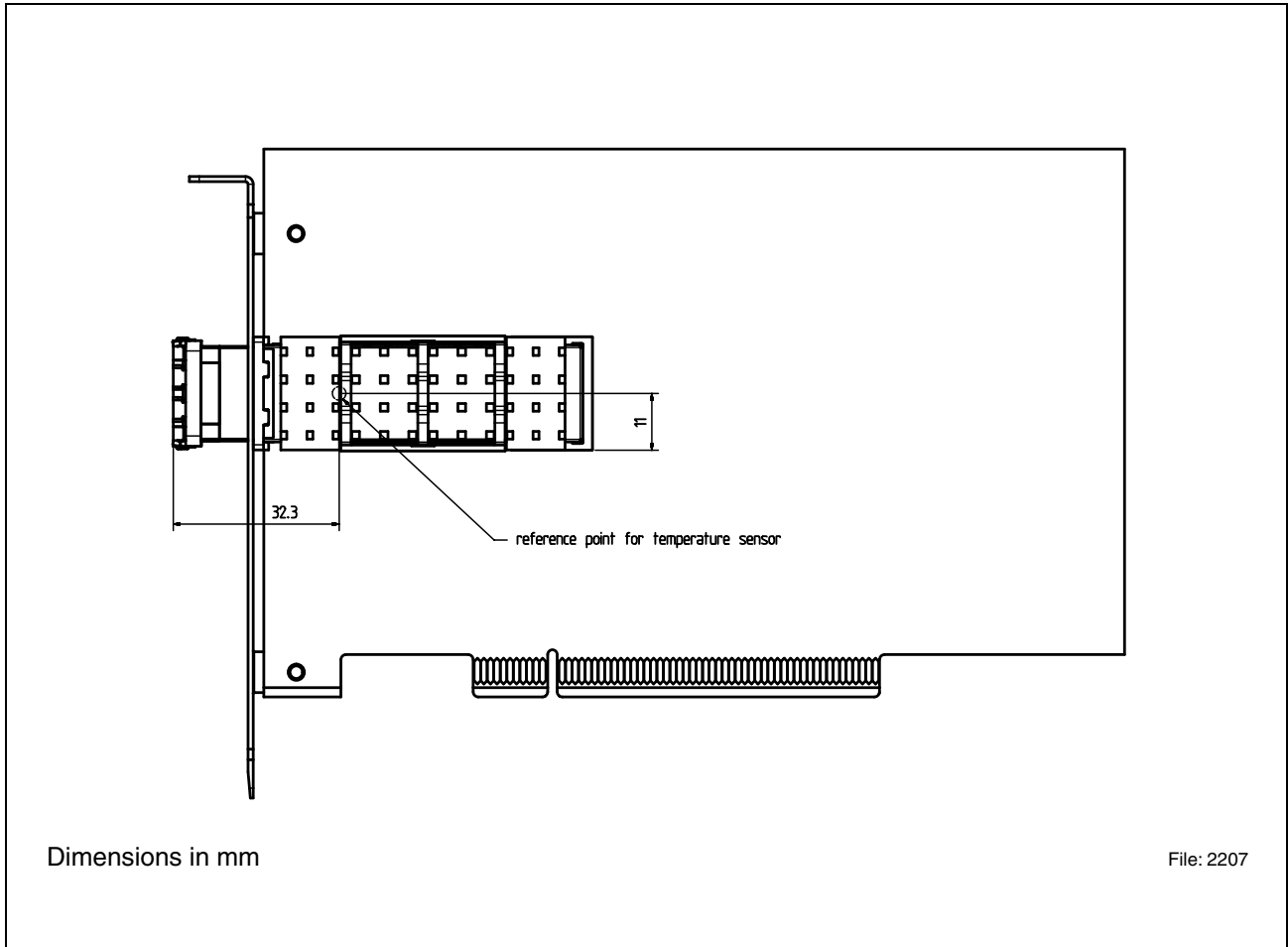

Figure 14 Label Description





**Figure 15 XFP Temperature Reference Point**

---

**V23833-F0005-B101**

**V23833-F0005-B102**

**Revision History:**            **2004-06-16**

DS0

---

Previous Version:            none

---

<b>Page</b>	<b>Subjects (major changes since last revision)</b>

---

**Edition 2004-06-16**

**Published by Infineon Technologies AG,  
St.-Martin-Strasse 53,  
81669 München, Germany**

**© Infineon Technologies AG 2004.  
All Rights Reserved.**

**Attention please!**

The information herein is given to describe certain components and shall not be considered as a guarantee of characteristics.

Terms of delivery and rights to technical change reserved.

We hereby disclaim any and all warranties, including but not limited to warranties of non-infringement, regarding circuits, descriptions and charts stated herein.

**Information**

For further information on technology, delivery terms and conditions and prices please contact your nearest Infineon Technologies Office ([www.infineon.com](http://www.infineon.com)).

**Warnings**

Due to technical requirements components may contain dangerous substances. For information on the types in question please contact your nearest Infineon Technologies Office.

Infineon Technologies Components may only be used in life-support devices or systems with the express written approval of Infineon Technologies, if a failure of such components can reasonably be expected to cause the failure of that life-support device or system, or to affect the safety or effectiveness of that device or system. Life support devices or systems are intended to be implanted in the human body, or to support and/or maintain and sustain and/or protect human life. If they fail, it is reasonable to assume that the health of the user or other persons may be endangered.