

RED**TOSHIBA T-1¾ InGaAlP Ultra Bright LED**

TLSE157P

Product Features -

- InGaAlP Technology
- T-1¾ (5 mm) Package
- High Intensity Red Light ($\lambda_p = 623 \text{ nm}$) Emission
- Water Clear Lens

MAXIMUM RATINGS ($T_a = 25^\circ\text{C}$)

CHARACTERISTIC	SYMBOL	RATING	UNIT
Forward Current	I_F	50	mA
Reverse Voltage	V_R	4	V
Power Dissipation	P_D	120	mW
Operating Temperature	T_{opr}	-30 ~ 85	$^\circ\text{C}$
Storage Temperature	T_{stg}	-40 ~ 120	$^\circ\text{C}$

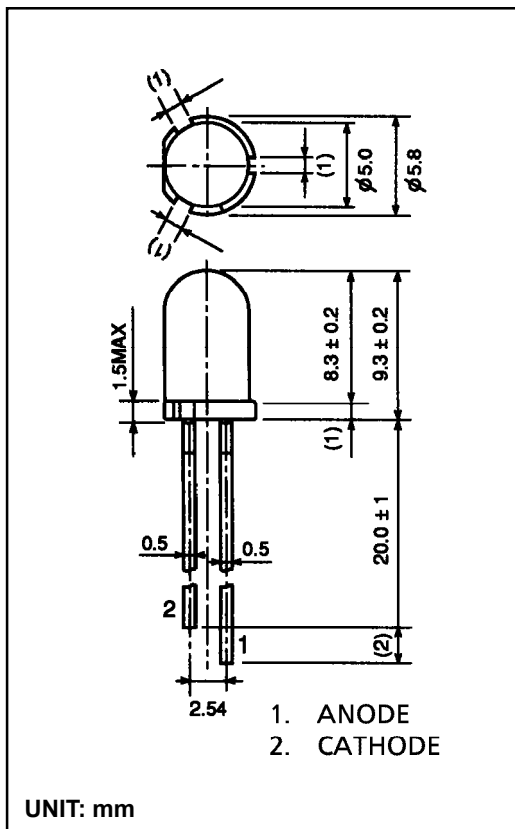

OPTO-ELECTRICAL CHARACTERISTICS ($T_a = 25^\circ\text{C}$)

CHARACTERISTIC	SYMBOL	TEST CONDITION	MIN.	TYP.	MAX.	UNIT
Forward Voltage	V_F	$I_F = 20\text{mA}$	—	1.95	2.4	V
Reverse Current	I_R	$V_R = 4\text{V}$	—	—	50	μA
Luminous Intensity	I_v	$I_F = 20\text{mA}$	475	1400	—	mcd
Viewing Angle	$2\theta_{1/2}$	—	—	22	—	$^\circ$
Peak Wavelength	λ_p	$I_F = 20\text{mA}$	—	623	—	nm
Dominant Wavelength	λ_d	$I_F = 20\text{mA}$	—	613	—	nm
Spectral Line Half Width	$\Delta\lambda$	$I_F = 20\text{mA}$	—	15	—	nm

* Luminous Ranks: (R : 560-1120mcd), (S : 1000-2000mcd), (T : 1800-3600mcd) Upper and lower limit tolerance $\pm 15\%$
Available in Three Bin Combinations: (RS), (ST)

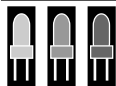

marktech
optoelectronics

120 Broadway • Menands, New York 12204

Toll Free: **(800) 98-4LEDS** • Fax: (518) 432-7454

TLSE157P Graphs -

