

1. Measurement condition :

Ambient temperature T_A : 23 °C
 Input power level: 0 dBm.
 Terminating impedances at f_C : for input: 829 Ω | - 19,55 pF.
 for output: 1133 Ω | - 12,78 pF.
 Q-value of matching elements: 30

2. Characteristics :

Remark:

Reference level for the relative attenuation a_{rel} of the **TFS 36C** is the minimum of the pass band attenuation a_{min} . The minimum of the pass band attenuation a_{min} is defined as the insertion loss a_e . The centre frequency f_C is the arithmetic mean value of the upper and lower frequencies at the 40 dB filter attenuation level relative to the insertion loss a_e . The nominal frequency f_N is fixed on 36 MHz without tolerance. The temperature coefficient of frequency T_C is valid both for the reference frequency f_C and the frequency response of the filter in the operating temperature range. The frequency shift of the filter in the operating temperature range is included in the production tolerance scheme.

Data	typ. value	tolerance / limit
Insertion loss (Reference level) a_e	24...25 dB	max. 36 dB
Nominal frequency : f_N		36 MHz
Centre frequency f_C at ambient temperature T_A (f_{CAT})	36,005 MHz	
Pass band (PB) :		$f_N - 0,75$ MHz ... $f_N + 0,75$ MHz
Bandwidth at operating temperature:		
1 dB - band width	1,565 MHz	min. 1,50 MHz
40 dB - band width	2,245 MHz	max. 2,30 MHz
45 dB - band width	2,250 MHz	max. 2,60 MHz
Amplitude ripple in pass band (p-p) :	0,7 dB	max. 1 dB
Relative attenuation a_{rel}		
f_N ... $f_N \pm 0,75$ MHz	-	max. 1 dB
$f_N \pm 1,15$ MHz ... $f_N \pm 1,3$ MHz	45 dB	min. 40 dB
$f_N \pm 1,3$ MHz ... $f_N \pm 35$ MHz	46...65 dB	min. 45 dB
Group delay (mean value in PB):	4,08 μ s	
Group delay ripple in PB (p-p):	100...120 ns	
Deviation from linear phase in PB (p-p):	2,5...3,5° (r.m.s. 0,8 °)	max. 4° p-p
Triple transit attenuation compared to main signal	58...62 dB	min. 55 dB
Crosstalk	60...70 dB	
Frequency inversion temperature (T_o)	0 °C	
Temperature coefficient of frequency (T_C)	0,036 ppm/°C	
Frequency deviation of f_C over temperature: *)	$\Delta f_C(\text{Hz}) = T_C(\text{ppm/K}) \times (T - T_o)^2 \times f_{T_o}$ (MHz)	
Operating temperature		+ 45 °C
Storage temperature range		- 25 °C ... + 85 °C

*) f_{T_o} is reference frequency f_C at frequency inversion temperature (T_o)

Generated:

Dunzow W.P.

Checked/Approved:

Dr. Bert Wall

VI TELEFILTER
 Potsdamer Straße 18
 D 14 513 TELTOW / Germany
 Tel: (+49) 3328 4784-52 / Fax: (+49) 3328 4784-30
 E-Mail: tft@telefilter.com

Vectron International, Inc.
 267 Lowell Road
 Hudson, NH 03051 / USA
 Tel: (603) 598-0070 Fax: (603) 598-0075
 E-Mail: vti@vtinh.com

VI TELEFILTER reserves the right to make changes to the product(s) and/or information contained herein without notice. No liability is assumed as a result of their use or application. No rights under any patent accompany the sale of any such product(s) or information.

3. Package :

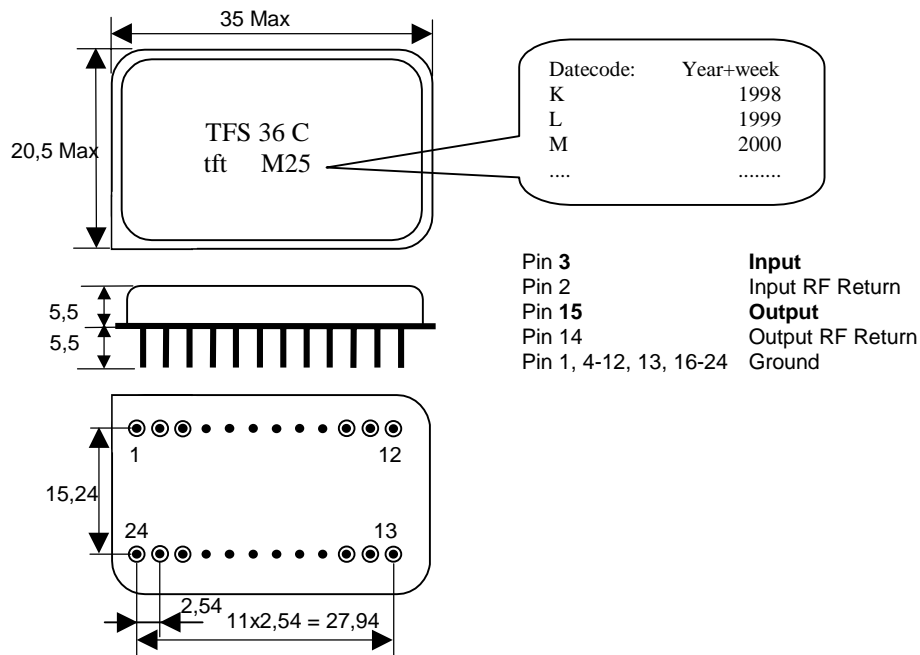
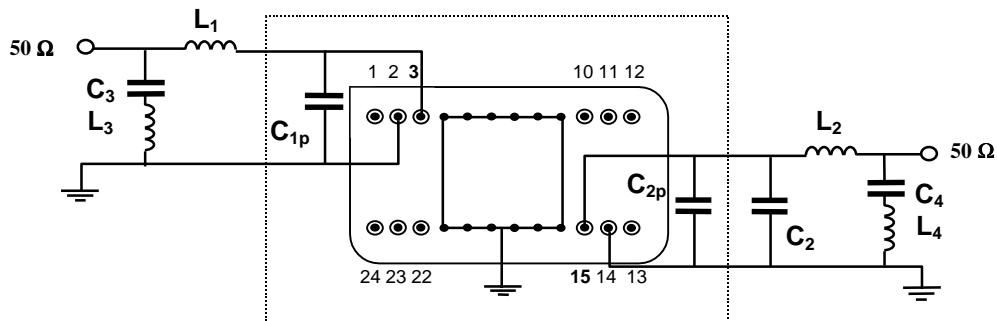
4. 50 Ω matching network :

About values [$C_{1...4}$, $L_{1...4}$ and C_{1p} , C_{2p}] see Application Note TFS 36C.

5. Soldering temperature conditions :

Soldering temperature profile

Name:	pre-heating periods	main-heating periods	peak temperature
Temperature:	150 °C - 170 °C	over 200 °C	255 °C ± 5 °C
Time:	60 sec. - 90 sec.	20 sec. - 25 sec.	

Soldering temperature profile

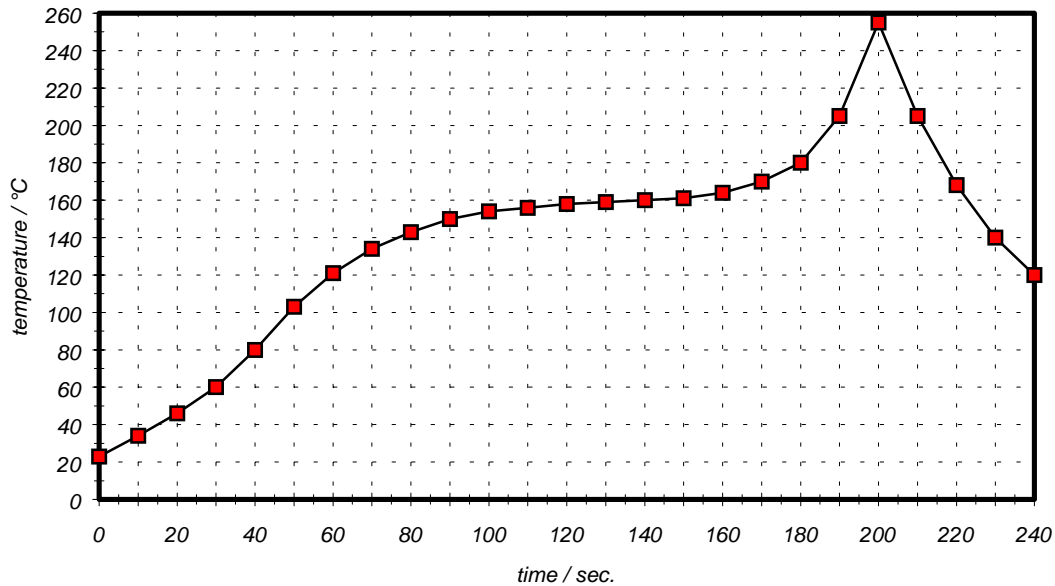

Table for temperature vs. time during the soldering process

Tolerance of temperatures: ± 5 °C

time / sec.	temperature / °C	time / sec.	temperature / °C
0	23	140	160
10	34	150	161
20	46	160	164
30	60	170	170
40	80	180	180
50	103	190	205
60	121	195	230
70	134	200	255
80	143	205	230
90	150	210	205
100	154	215	180
110	156	220	165
120	158	230	140
130	159	240	120

History

Version	Reason of Changes	Name	Date
1.0...1.3	Generate Development Specification according to customer requirements.	Dr. Wall	12.12.1999
1.4	Add typical values of Data . Add matching networks. Add Termination Impedances .	Dunzow W.	28.06.2000