

**Low EMI Spread Spectrum Multiplier Clock**

**FEATURES**

- Spread Spectrum clock with frequency range of 33 ~ 90MHz.
- Output frequency 1X the input frequency.
- Less than 250 ps skew between outputs.
- Less than 100 ps cycle - cycle jitter.
- $\pm 0.50\%$  Center Spread Modulation ( $\pm 15\%$  tolerance).
- TTL/CMOS compatible outputs.
- 3.3V operation.
- Available in 8-Pin 150mil SOIC.

**PIN CONFIGURATION**

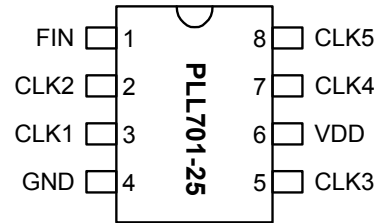

FIN = 33 ~ 90 Mhz

**DESCRIPTION**

The PLL701-25 is a Spread Spectrum Clock Generator designed for the purpose of reducing EMI in high-speed digital systems. The device is designed to operate from 33 ~ 90MHz and provides five low-skew outputs.

**BLOCK DIAGRAM**

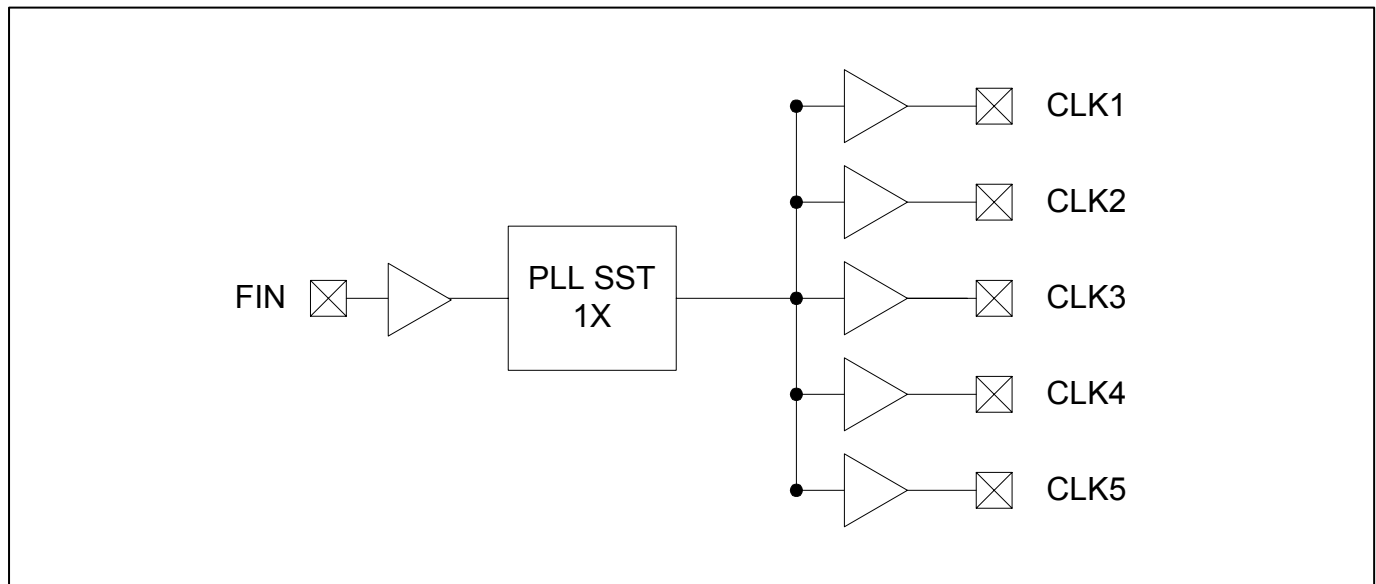

## Low EMI Spread Spectrum Multiplier Clock

### PIN DESCRIPTIONS

Name	Number	Type	Description
FIN	1	I	Input Clock Frequency. ( 33 ~ 90MHz )
CLK2	2	O	Buffered Clock Output. 1X the input frequency ( FIN ).
CLK1	3	O	Buffered Clock Output. 1X the input frequency ( FIN ).
GND	4	I	Ground.
CLK3	5	O	Buffered Clock Output. 1X the input frequency ( FIN ).
VDD	6	P	3.3V Power Supply.
CLK4	7	O	Buffered Clock Output. 1X the input frequency ( FIN ).
CLK5	8	O	Buffered Clock Output. 1X the input frequency ( FIN ).

### ELECTRICAL SPECIFICATIONS

#### 1. Absolute Maximum Ratings

PARAMETERS	SYMBOL	MIN.	MAX.	UNITS
Supply Voltage	$V_{DD}$		4.6	V
Input Voltage, dc	$V_I$	-0.5	$V_{DD}+0.5$	V
Output Voltage, dc	$V_O$	-0.5	$V_{DD}+0.5$	V
Storage Temperature	$T_S$	-65	150	°C
Ambient Operating Temperature*	$T_A$	-40	85	°C
Junction Temperature	$T_J$		125	°C
Lead Temperature (soldering, 10s)			260	°C
ESD Protection, Human Body Model			2	kV

Exposure of the device under conditions beyond the limits specified by Maximum Ratings for extended periods may cause permanent damage to the device and affect product reliability. These conditions represent a stress rating only, and functional operations of the device at these or any other conditions above the operational limits noted in this specification is not implied.

\* **Note:** Operating Temperature is guaranteed by design for all parts (COMMERCIAL and INDUSTRIAL), but tested for COMMERCIAL grade only.

#### 2. Electrical Characteristics

PARAMETERS	SYMBOL	CONDITIONS	MIN.	TYP.	MAX.	UNITS
Supply Voltage	$V_{DD}$		2.97		3.63	V
Input Low Voltage	$V_{IL}$				0.8	V
Input High Voltage	$V_{IH}$		2.0			V
Input Low Current	$I_{IL}$	$V_{IN} = 0V$		19	50.0	μA
Input High Current	$I_{IH}$	$V_{IN} = V_{DD}$		0.10	100.0	μA
Output Low Voltage	$V_{OL}$	$I_{OL} = 50\text{ mA}$		0.25	0.4	V
Output High Voltage	$V_{OH}$	$I_{OH} = 50\text{ mA}$	2.4	2.9		V
Supply Current	$I_{DD}$	Unloaded outputs at 75MHz, SEL inputs at $V_{DD}$ or GND		30.0	40.0	mA

## Low EMI Spread Spectrum Multiplier Clock

### 3. Timing Characteristics

PARAMETERS	SYMBOL	CONDITIONS	MIN.	TYP.	MAX.	UNITS
Input Frequency	$F_{IN}$		33		90	MHz
Rise Time	$T_r$	Measured at 0.8V ~ 2.0V @ 3.3V	0.8	0.95	1.1	ns
Fall Time	$T_f$	Measured at 2.0V ~ 0.8V @ 3.3V	0.78	0.85	0.9	ns
Output Duty Cycle	$D_T$		45	50	55	%
Input to Output Delay			2		4	ns
Cycle to Cycle Jitter	$T_{cyc-cyc}$	Over output frequency range @ 3.3V			100	ps

**Low EMI Spread Spectrum Multiplier Clock**

**PACKAGE INFORMATION**

8 PIN Narrow SOIC ( mm )

Symbol	SOIC	
	Min.	Max.
A	1.47	1.73
A1	0.10	0.25
B	0.33	0.51
C	0.19	0.25
D	4.80	4.95
E	3.80	4.00
H	5.80	6.20
L	0.38	1.27
e	1.27 BSC	

**ORDERING INFORMATION**

**For part ordering, please contact our Sales Department:**

47745 Fremont Blvd., Fremont, CA 94538, USA  
Tel: (510) 492-0990 Fax: (510) 492-0991

**PART NUMBER**

The order number for this device is a combination of the following:  
Device number, Package type and Operating temperature range

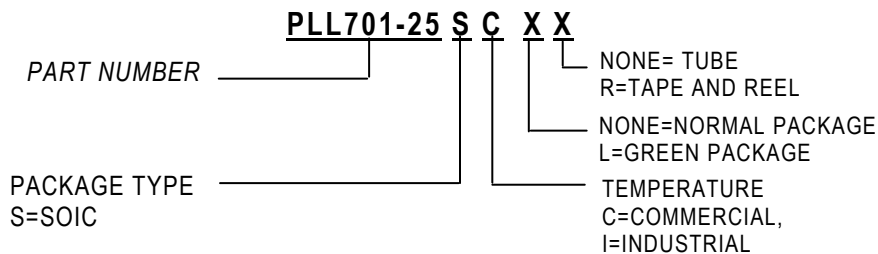

Part / Order Number	Marking	Package Option	Temperature
PLL701-25SC-R	P701-25SC	SOIC -Tape and Reel	0 to +70° C
PLL701-25SC	P701-25SC	SOIC -Tube	0 to +70° C
PLL701-25SCL-R	P702-25SCL	SOIC -Tape and Reel (GREEN)	0 to +70° C
PLL701-25SCL	P702-25SCL	SOIC -Tubes (GREEN)	0 to +70° C

PhaseLink Corporation, reserves the right to make changes in its products or specifications, or both at any time without notice. The information furnished by Phaselink is believed to be accurate and reliable. However, PhaseLink makes no guarantee or warranty concerning the accuracy of said information and shall not be responsible for any loss or damage of whatever nature resulting from the use of, or reliance upon this product.

**LIFE SUPPORT POLICY:** PhaseLink's products are not authorized for use as critical components in life support devices or systems without the express written approval of the President of PhaseLink Corporation.