

MF1090V-3

FOR E-GSM MOBILE TELEPHONE, Rx

MF1090V-3

DESCRIPTION

This SAW filter for the receiving RF circuit of E-GSM mobile communication equipment operating at 925 MHz ~ 960 MHz.

FEATURES

1. SMD package insures small size, lightweight.
2. Adjustment free.
3. Low insertion loss and high stop band attenuation.
4. Wide and sharp passband characteristics.
5. High stability and reliability.
6. Designed for reflow solderings.

APPLICATION

- Mobile cellular telephone
- Portable digital cellular telephone
- Wireless equipment

MAXIMUM RATINGS

Rating	Value	Unit
Input Power	50	mW
Operating Temperature Range	-20 to 75	°C
Storage Temperature Range	-30 to 85	°C

ELECTRICAL PERFORMANCE

Parameter	MF1090V-3			Units
	Min	Typ	Max	
PASSBAND FREQUENCY	925 - 960			MHz
PASSBAND CHARACTERISTICS	Insertion Loss	2.8	3.5	dB
	Ripple	1.1	2.0	
	VSWR	2.3	3.0	
STOPBAND ATTENUATION	810 - 830 MHz	35	45	dB
	870 - 885 MHz	30	43	
	1070 - 1090 MHz	40	45	
	1130 - 1145 MHz	40	47	
	1850 - 1920 MHz	30	36	
	2775 - 2880 MHz	10	26	

PACKAGE OUTLINE DIMENSIONS

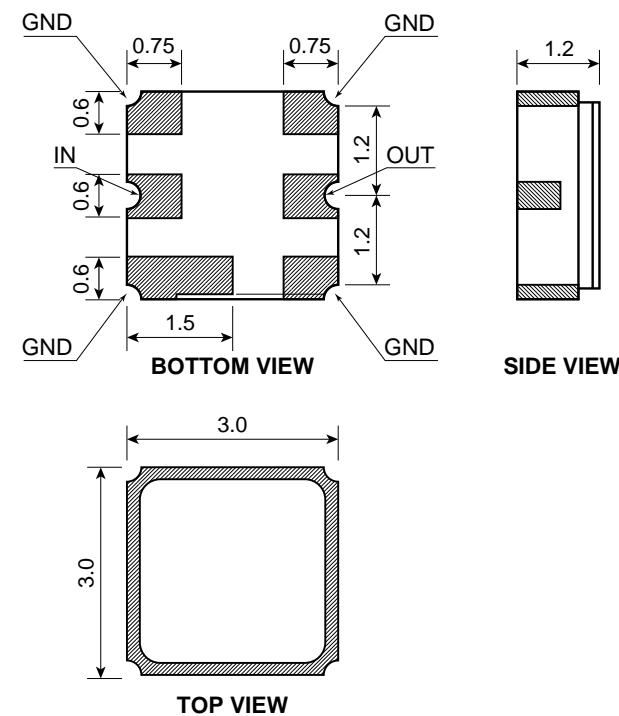

DIMENSIONS ARE IN MILLIMETERS
±0.2 UNLESS OTHERWISE SPECIFIED

MF1090V-3 TYPICAL CHARACTERISTICS

