

MF1090S-1

FOR E-GSM MOBILE TELEPHONE, Rx

MF1090S-1

DESCRIPTION

This SAW filter for the receiving RF circuit of E-GSM mobile communication equipment operating at 925 MHz ~ 958 MHz.

FEATURES

1. SMD package insures small size, lightweight.
2. Adjustment free.
3. Low insertion loss and high stop band attenuation.
4. Wide and sharp passband characteristics.
5. High stability and reliability.
6. Designed for reflow solderings.

APPLICATION

- Digital mobile cellular telephone
- Portable digital cellular telephone
- Wireless equipment

MAXIMUM RATINGS

Rating	Value	Unit
Input Power	50	mW
Operating Temperature Range	-20 to 75	°C
Storage Temperature Range	-30 to 85	°C

ELECTRICAL PERFORMANCE

PRELIMINARY

Parameter	MF1090S-1			Units
	Min	Typ	Max	
PASSBAND FREQUENCY	925 – 958			MHz
PASSBAND CHARACTERISTICS	Insertion Loss	2.9	3.5	dB
	Ripple	1.2	2.0	
	VSWR	2.3	3.0	
STOPBAND ATTENUATION	775 – 806 MHz	25	31	dB
	810 – 885 MHz	28	32	
	1000 – 1031 MHz	30	34	
	1075 – 1106 MHz	28	33	
	1150 – 1181 MHz	28	33	
1225 – 1256 MHz	28	33	dB	

PACKAGE OUTLINE DIMENSIONS

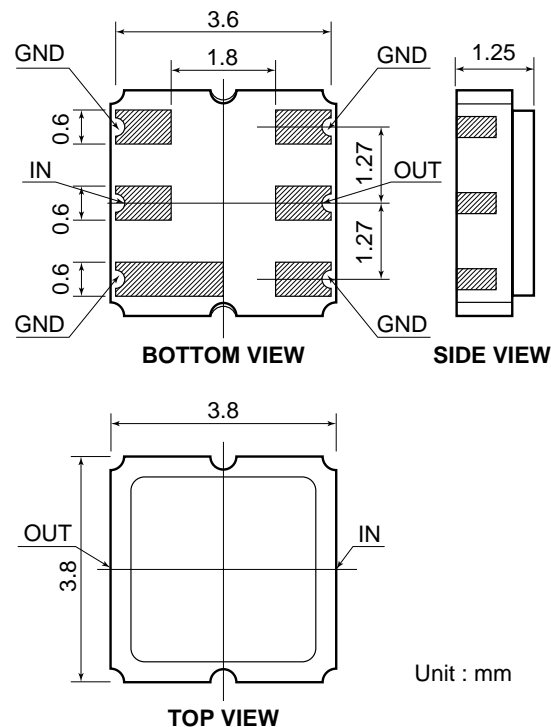

DIMENSIONS ARE IN MILLIMETERS
±0.2 UNLESS OTHERWISE SPECIFIED

MF1090S-1 TYPICAL CHARACTERISTICS

