

**High Power PHEMT**  
600 – 4000 MHz, 30 dBm Linear Pout, 10 watt P1dB

MAAP-008171  
V2P

**Features**

- Ideal for WiMax, MESH Network, and Linear Applications
- Small Signal Gain: 11 dB Typical
- EVM: 2.5% at 30 dBm Linear (OFDM) P<sub>OUT</sub>
- Includes thermally-coupled reference FET for use in external biasing circuit
- Lead-Free 4 mm 16 lead PQFN Package
- 100% Matte Tin Plating over Copper
- Halogen-Free “Green” Mold Compound
- RoHS\* Compliant and 260°C Reflow Compatible

**Description**

M/A-Com's MAAP-008171 is an unmatched high power GaAs pHEMT which exhibits high gain and linearity performance in a lead-free 4mm PQFN 16-Lead surface mount plastic package. This part is tunable over a frequency range from 600 MHz to 4000 MHz making it ideal many linear applications such as CDMA, WCDMA, and WiMax.

This part can achieve 27 dBm /30 dBm Linear Pout when measured for 802.16d (EVM < 2.5%) when operated @ 12V. It also contains a thermally-coupled reference transistor to allow simple current mirror biasing.

The MAAP-008171 is fabricated using a high reliability GaAs PHEMT process to realize low current and high power functionality. The process features full passivation for increased performance and reliability.

**Ordering Information**<sup>1</sup>

Part Number	Package
MAAP-008171-TR3000	3000 piece reel
MAAP-008171-001SMB	900 MHz Sample Test Board (Includes 5 Samples)
MAAP-008171-002SMB	1.9 GHz Sample Test Board (Includes 5 Samples)
MAAP-008171-003SMB	2.5 GHz Sample Test Board (Includes 5 Samples)
MAAP-008171-004SMB	3.5 GHz Sample Test Board (Includes 5 Samples)

1. Reference Application Note M513 for reel size information.

***This PRELIMINARY Data Sheet contains information regarding a product M/A-COM is considering for development. Performance is based on simulated results or target specifications. Commitment to produce in volume is not guaranteed.***

\* Restrictions on Hazardous Substances, European Union Directive 2002/95/EC.

**Block Diagram**

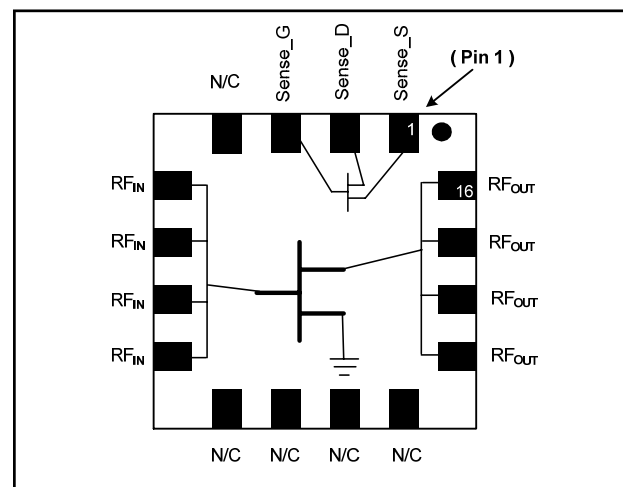

**Pin Configuration**

Pin No.	Pin Name	Description
1	Sense_S	Source of Reference Device
2	Sense_D	Drain of Reference Device
3	Sense_G	Gate of Reference Device
4	N/C	No Connection
5-8	RF <sub>IN</sub>	RF Input/Gate Bias
9-12	N/C	No Connection
13-16	RF <sub>OUT</sub>	RF Output/Drain Bias
17	Paddle <sup>2</sup>	RF & DC Ground

2. The exposed pad centered on the package bottom must be connected to RF and DC ground.

**Absolute Maximum Ratings**<sup>3,4</sup>

Parameter	Absolute Maximum
Input Power	+ 32 dBm
Operating Supply Voltage	+12.0 Volts
Gate Voltage	+1 Volts
Operating Temperature	-30 °C to +85 °C
Channel Temperature	+150 °C
Storage Temperature	-40 °C to +150 °C

3. Exceeding any one or combination of these limits may cause permanent damage to this device.

4. M/A-COM does not recommend sustained operation near these survivability limits.

**High Power PHEMT**  
600 – 4000 MHz, 30 dBm Linear Pout, 10 watt P1dB

MAAP-008171  
V2P

**Electrical Specifications: F = 2.3 - 2.7 GHz, T<sub>A</sub> = +25 °C, V<sub>DD</sub> = 12.0 V, in test fixture**

Parameter	Test Conditions	Units	Min.	Typ.	Max.
Gain	2.5 GHz	dB	—	11	—
Input Return Loss	2.3 to 2.7 GHz	dB	—	5	—
Output P1dB	2.3 to 2.7 GHz OFDM application 2010 MHz CW application	dBm dBm	— —	37.5 39.5	— —
EVM	P <sub>OUT</sub> = 30 dBm OFDM, QAM-64 802.16	%	—	2.5	—
Device / Supply Voltage		V	—	12	—
Gate Voltage	V <sub>GG</sub> (for I <sub>DD</sub> = 200 mA)	V	—	-0.7	—
Active Supply Current	P <sub>OUT</sub> = 30 dBm	mA	—	420	—
PAE	P <sub>OUT</sub> = 30 dBm	%	—	18	—

**PCB Layout**

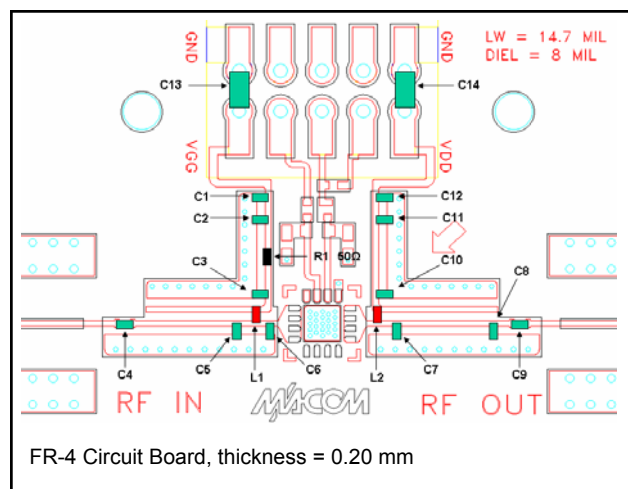

**Parts List**

Part	Value	Case Style	Manufacturer
C1,C12	0.1 µF	0402	Murata
C2,C11	1000 pF	0402	Murata
C3,C4,C9,C10	10 pF	0402	Murata
C5	1.6 pF	0402	Murata
C6,C7	3.3 pF	0402	Murata
C8	1.2 pF	0402	Murata
C13,C14	10 µF	1206	Murata
L1,L2	3.3 nH	0402	Coilcraft
R1	50 Ω	0402	Panasonic

**Handling Procedures**

Please observe the following precautions to avoid damage:

**Static Sensitivity**

Gallium Arsenide Integrated Circuits are sensitive to electrostatic discharge (ESD) and can be damaged by static electricity. Proper ESD control techniques should be used when handling these devices.

**Typical Performance Curves for OFDM Application:**

**Gain**

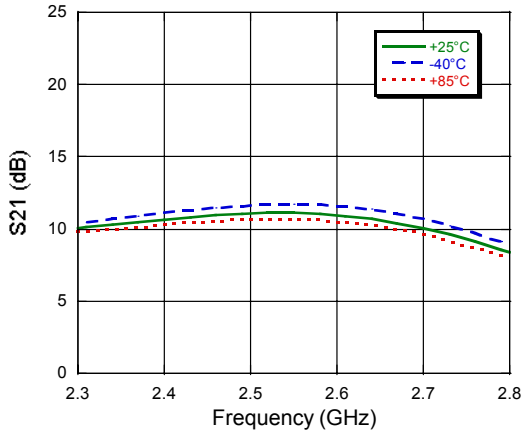

**Input Return Loss**

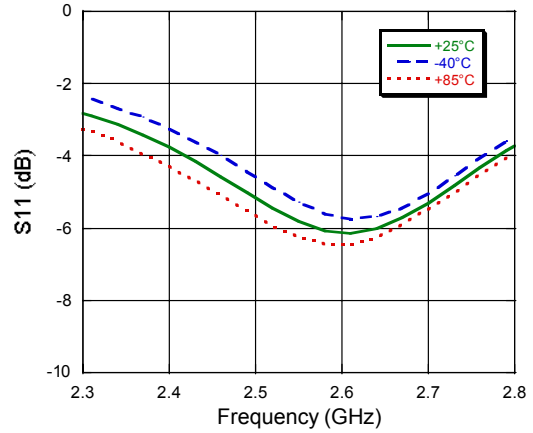

**Output Return Loss**

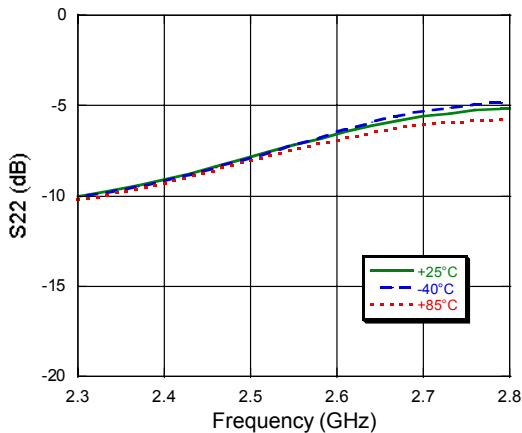

**EVM**

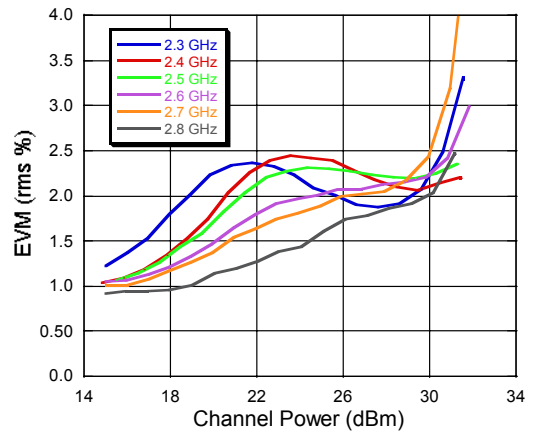

**P1dB vs. P<sub>OUT</sub> @ 2.5 GHz**

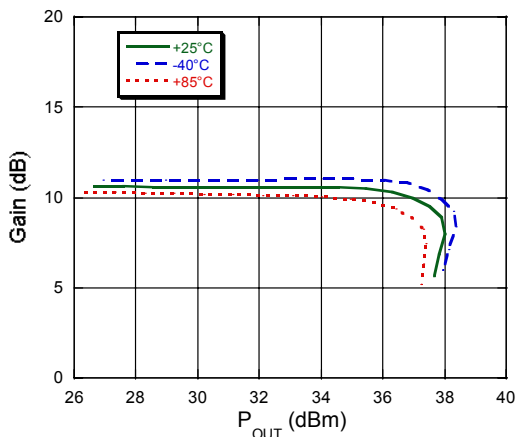

**PAE vs. P<sub>OUT</sub> @ 2.5 GHz**

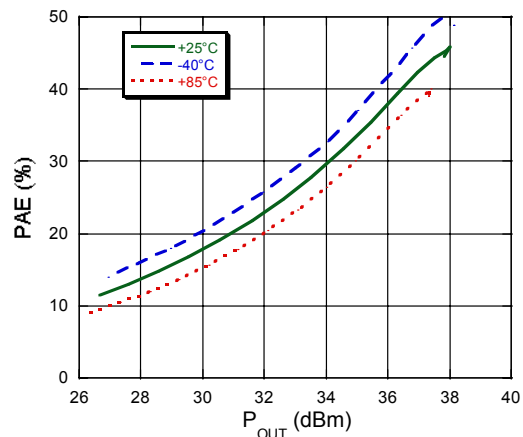

High Power PHEMT  
600 – 4000 MHz, 30 dBm Linear Pout, 10 watt P1dB

MAAP-008171  
V2P

**Typical Performance Curves for CW Application:**

**Gain**

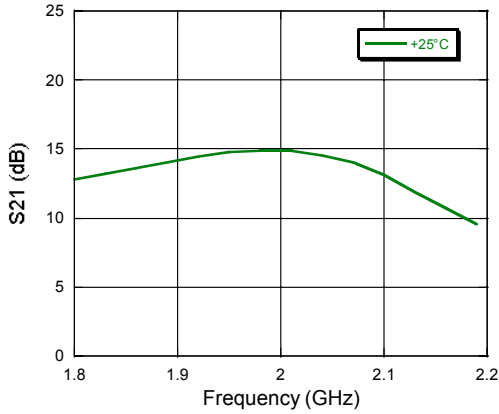

**Input Return Loss**

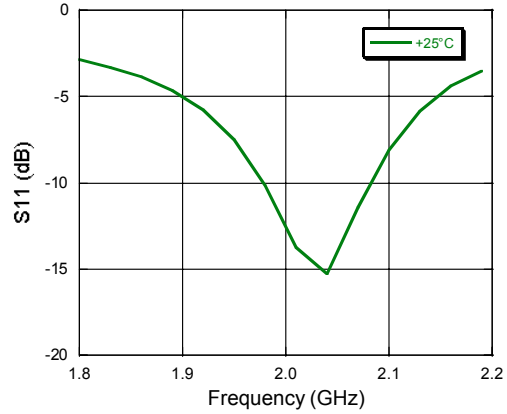

**Output Return Loss**

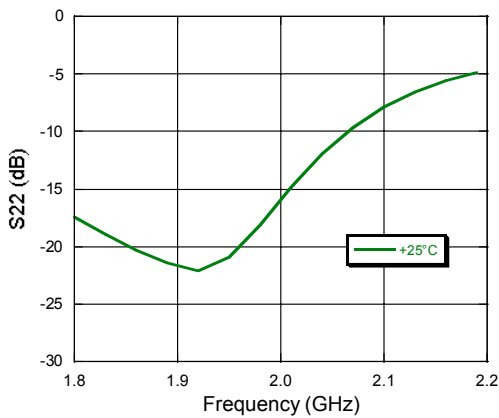

**P1dB vs. POUT**

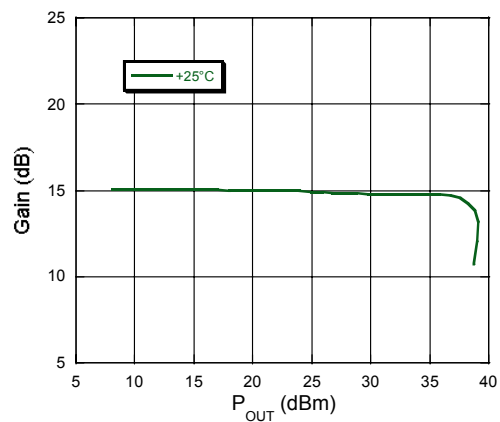

**Lead-Free 4 mm 16-Lead PQFN†**

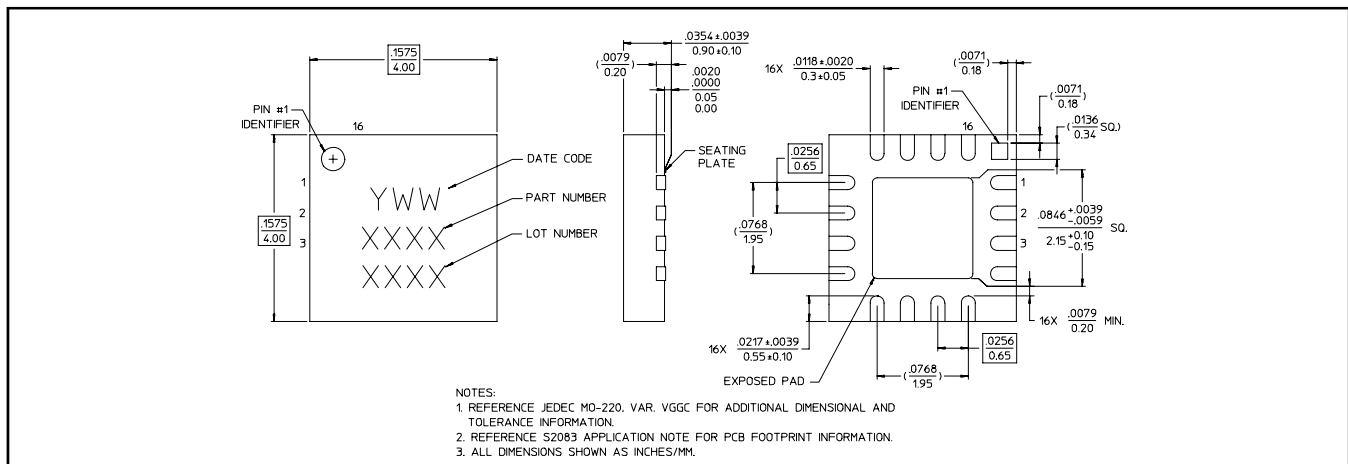

† Reference Application Note M538 for lead-free solder reflow recommendations.  
Meets JEDEC moisture sensitivity level 1 requirements.