

SOT-23 Formed SMD Package

**CMBD1201, CMBD1202, CMBD1203
CMBD1204, CMBD1205, CMBD4148**

SILICON PLANAR EPITAXIAL HIGH SPEED DIODES

*CMBD1201, 1202, CMBD4148 are all single diodes
CMBD1203 is a dual diode, in series
CMBD1204 is a dual diode, common cathode
CMBD1205 is a dual diode, common anode*

Marking

CMBD1201 – 24 CMBD1204 – 27
CMBD1202 – 25 CMBD1205 – 28
CMBD1203 – 26 CMBD4148 – 5H

PACKAGE OUTLINE DETAILS
ALL DIMENSIONS IN mm

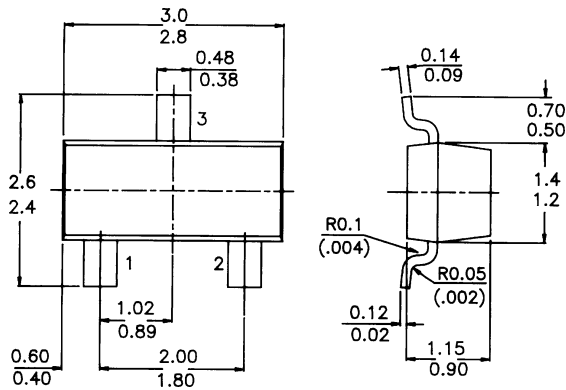
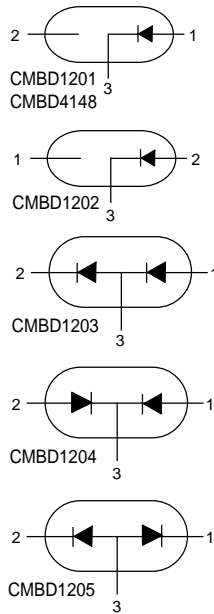

ABSOLUTE MAXIMUM RATINGS (per diode)

<i>Continuous reverse voltage</i>	V_R	max.	75 V
<i>Repetitive peak reverse voltage</i>	V_{RRM}	max.	100 V
<i>Repetitive peak forward current</i>	I_{FRM}	max.	500 mA
<i>Forward current</i>	I_F	max.	215 mA
<i>Junction temperature</i>	T_j	max.	150 °C
<i>Forward voltage at $I_F = 10$ mA</i>	V_F	<	0.855 V

**CMBD1201, CMBD1202, CMBD1203
CMBD1204, CMBD1205, CMBD4148**

Reverse recovery time when switched from

$I_F = 10 \text{ mA}$ to $I_R = 10 \text{ mA}$; $R_L = 100 \Omega$;
measured at $I_R = 1 \text{ mA}$

$t_{rr} < 4 \text{ ns}$

RATINGS (per diode) (at $T_A = 25^\circ\text{C}$ unless otherwise specified)

Limiting values

Continuous reverse voltage	V_R	max.	75 V
Repetitive peak reverse voltage	V_{RRM}	max.	100 V
Repetitive peak forward current	I_{FRM}	max.	500 mA
Forward current	I_F	max.	215 mA
Non-repetitive peak forward current (per crystal)			
$t = 1 \mu\text{s}$	I_{FSM}	max.	4 A
$t = 1 \text{ ms}$	I_{FSM}	max.	1.0 A
$t = 1 \text{ s}$	I_{FSM}	max.	0.5 A
Storage temperature	T_{stg}		-55 to +150 °C
Junction temperature	T_j	max.	150 °C

THERMAL RESISTANCE

From junction to ambient

$R_{th \text{ j-a}} = 500 \text{ K/W}$

CHARACTERISTICS (per diode)

$T_j = 25^\circ\text{C}$ unless otherwise specified

Forward voltage

$I_F = 10 \text{ mA}$	V_F	<	0.855 V
$I_F = 200 \text{ mA}$	V_F	<	1.05 V
$I_F = 10 \text{ mA}$ CMBD4148	V_F	<	1.0 V

Reverse currents

$V_R = 20 \text{ V}$	I_R	<	25 nA
$V_R = 75 \text{ V}$	I_R	<	5 μA
$V_R = 25 \text{ V}$; $T_j = 150^\circ\text{C}$	I_R	<	30 μA

Forward recovery voltage

$I_F = 10 \text{ mA}$; $t_p = 20 \text{ ns}$ $V_{fr} < 1.75 \text{ V}$

Recovery charge

$I_F = 10 \text{ mA}$ to $V_R = 5 \text{ V}$; $R = 100 \Omega$ $Q_s < 45 \text{ pC}$

Diode capacitance

$V_R = 0$; $f = 1 \text{ MHz}$ $C_d < 2 \text{ pF}$

Reverse recovery time when switched from

$I_F = 10 \text{ mA}$ to $I_R = 10 \text{ mA}$; $R_L = 100 \Omega$;
measured at $I_R = 1 \text{ mA}$

$t_{rr} < 4 \text{ ns}$

Disclaimer

The product information and the selection guides facilitate selection of the CDIL's Discrete Semiconductor Device(s) best suited for application in your product(s) as per your requirement. It is recommended that you completely review our Data Sheet(s) so as to confirm that the Device(s) meet functionality parameters for your application. The information furnished on the CDIL Web Site/ CD are believed to be accurate and reliable. CDIL however, does not assume responsibility for inaccuracies or incomplete information. Furthermore, CDIL does not assume liability whatsoever, arising out of the application or use of any CDIL product; neither does it convey any license under its patent rights nor rights of others. These products are not designed for use in life saving/support appliances or systems. CDIL customers selling these products (either as individual Discrete Semiconductor Devices or incorporated in their end products), in any life saving/support appliances or systems or applications do so at their own risk and CDIL will not be responsible for any damages resulting from such sale(s).

CDIL strives for continuous improvement and reserves the right to change the specifications of its products without prior notice.



CDIL is a registered Trademark of
Continental Device India Limited

C-120 Naraina Industrial Area, New Delhi 110 028, India.
Telephone + 91-11-2579 6150, 5141 1112 Fax + 91-11-2579 5290, 5141 1119
mail@cdil.com www.cdilsemi.com