

## 6, 8 PIN DIP 250 V BREAK DOWN VOLTAGE NORMALLY CLOSED TYPE 1-CH, 2-CH OPTICAL COUPLED MOSFET

PS7122A-1B, -2B  
PS7122AL-1B, -2B

### FEATURES

- **1 CHANNEL TYPE:**  
1b Output
- **2 CHANNEL TYPE:**  
1b + 1b Output
- **DESIGNED FOR AC/DC SWITCHING LINE CHANGER**
- **SMALL AND THIN PACKAGE:**  
6, 8 PIN DIP
- **LOW LED OPERATING CURRENT:**  
 $I_F = 2 \text{ mA}$
- **LOW OFFSET VOLTAGE**
- **SURFACE MOUNT AVAILABLE**

### DESCRIPTION

PS7122A-1B, -2B and PS7122AL-1B, -2B are solid state relays containing a GaAs LED on the light emitting side (input side) and normally close (N.C.) contact MOSFETs on the output side.

They are suitable for analog signal control because of their low offset and high linearity.

### APPLICATIONS

- EXCHANGE EQUIPMENT
- MEASUREMENT EQUIPMENT
- FA/OA EQUIPMENT

### ELECTRICAL CHARACTERISTICS (T<sub>A</sub> = 25°C)

PART NUMBER			PS7122A-1B, -2B, PS7122AL-1B, -2B			
SYMBOLS	PARAMETERS	UNITS	MIN	TYP	MAX	
Diode	V <sub>F</sub>	Forward Voltage, I <sub>F</sub> = 10 mA	V	1.2	1.4	
	I <sub>R</sub>	Reverse Current, V <sub>R</sub> = 5 V	μA		5.0	
MOSFET	I <sub>Loff</sub>	Off-State Leakage Current, I <sub>F</sub> = 10 mA, V <sub>D</sub> = 250 V	μA	0.03	1.0	
	C <sub>OUT</sub>	Output Capacitance, I <sub>F</sub> = 10 mA, V = 0 V, f = 1 MHz	pF/ch	340		
Coupled	R <sub>on1</sub>	On-State Resistance, I <sub>F</sub> = 0 mA, I <sub>L</sub> = 10 mA	Ω	4.5	8.0	
	R <sub>on2</sub>					I <sub>F</sub> = 0 mA, I <sub>L</sub> = 200 mA, t <sub>s</sub> ≤ 10 ms
	t <sub>on</sub>	Turn-On Time <sup>1</sup>	I <sub>F</sub> = 10 mA, V <sub>L</sub> = 5 V, R <sub>L</sub> = 500 Ω,	ms	0.04	0.2
	t <sub>off</sub>	Turn-Off Time <sup>1</sup>	PW ≥ 10 ms	ms	0.5	1.5
	R <sub>I-O</sub>	Isolation Resistance, V <sub>in-out</sub> = 1.0 kVDC	Ω	10 <sup>9</sup>		
C <sub>I-O</sub>	Isolation Capacitance, V = 0 V, f = 1 MHz	pF/ch		1.1		

Note:

1. Turn-On, Turn-Off Time.

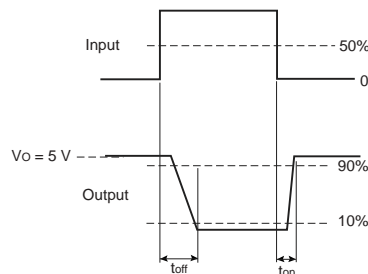
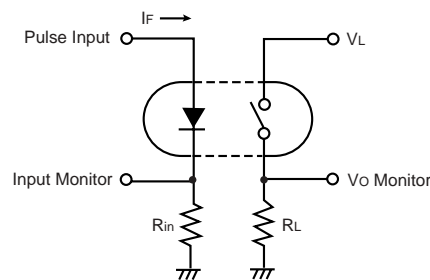

PS7122A-1B  
PS7122AL-1B

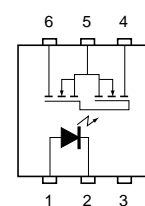

PS7122A-2B  
PS7122AL-2B

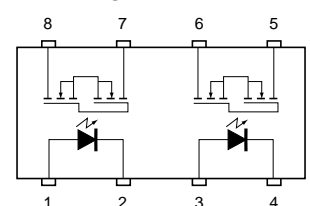

# PS7122A-1B, -2B, PS7122AL-1B, -2B

## ABSOLUTE MAXIMUM RATINGS<sup>1</sup> (T<sub>A</sub> = 25°C)

SYMBOLS	PARAMETERS	UNITS	RATINGS	
			PS7122A-1B PS7122AL-1B	PS7122A-2B PS7122AL-2B
Diode				
V <sub>R</sub>	Reverse Voltage	V	5	
I <sub>F</sub>	Forward Current (DC)	mA	50	
P <sub>D</sub>	Power Dissipation	mW/ch	50	
I <sub>F</sub> (Peak)	Peak Forward Current <sup>2</sup>	A	1	
MOSFET				
V <sub>L</sub>	Break Down Voltage	V	250	
I <sub>L</sub>	Continuous Load Current <sup>3</sup>	mA	200	
	Connection A		350	—
	Connection B		500	—
I <sub>LP</sub>	Pulse Load Current <sup>4</sup> AC/DC Connection			
P <sub>D</sub>	Power Dissipation	mW/ch	560	375
Coupled				
BV	Isolation Voltage <sup>5</sup>	Vr.m.s.	1500	1500
P <sub>T</sub>	Total Power Dissipation	mW	610	850
T <sub>STG</sub>	Storage Temperature	°C	-40 to +100	-40 to +100
T <sub>A</sub>	Operating Ambient Temp.	°C	-40 to +80	-40 to +80

Notes:

1. Operation in excess of any one of these parameters may result in permanent damage.
2. PW = 100 μs, Duty Cycle = 1 %
3. Conditions: I<sub>F</sub> ≥ 2 mA. The following types of load connections are available:

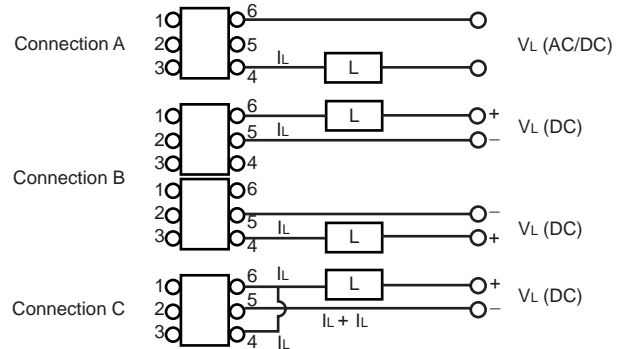

4. PW = 100 ms, 1 shot.
5. AC voltage for 1 minute at T<sub>A</sub> = 25 °C, RH = 60 % between input and output.

## RECOMMENDED

### OPERATING CONDITIONS (T<sub>A</sub> = 25 °C)

SYMBOL	PARAMETER	UNITS	MIN	TYP	MAX
I <sub>F</sub>	LED Operating Current	mA	2	10	20
V <sub>F</sub>	LED Off Voltage	V	0		0.5

## OUTLINE DIMENSIONS (Units in mm)

## ORDERING INFORMATION

PART NUMBER	PACKAGE	PACKING STYLE
PS7122A-1B	6-pin DIP	Magazine case 50 pcs
PS7122AL-1B		Embossed tape 1000 pcs/reel
PS7122AL-1B-E3	8-pin DIP	Magazine case 50 pcs
PS7122AL-1B-E4		
PS7122A-2B	8-pin DIP	Magazine case 50 pcs
PS7122AL-2B		Embossed tape 1000 pcs/reel
PS7122AL-2B-E3	8-pin DIP	Magazine case 50 pcs
PS7122AL-2B-E4		

**OUTLINE DIMENSIONS** (Units in mm)

**PS7122A-1B**

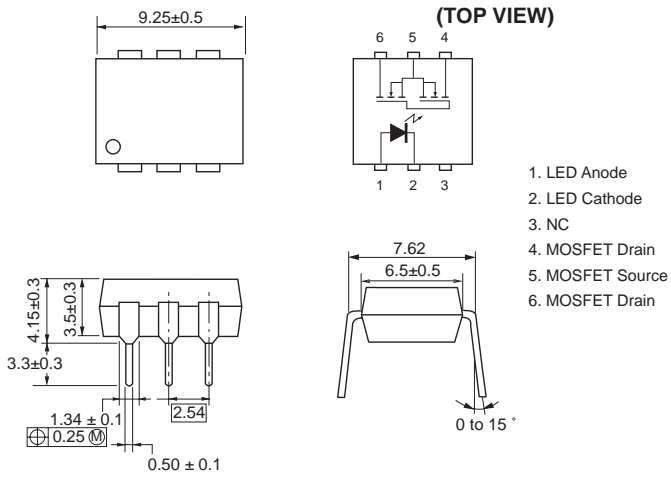

**PS7122AL-1B**

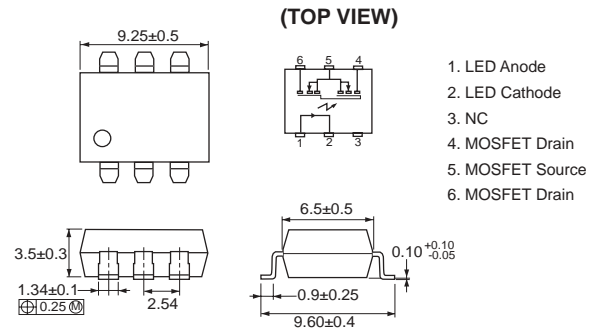

**PS7122A-2B**

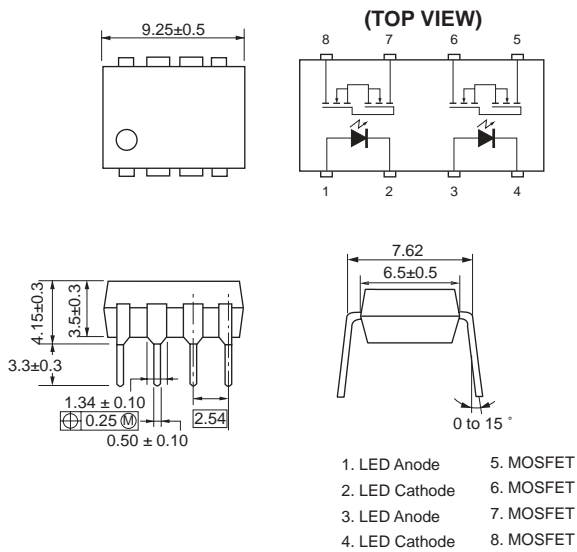

**PS7522AL-2B**

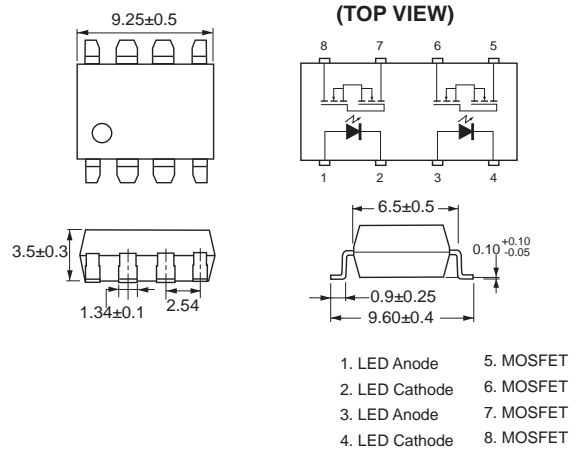

**TYPICAL PERFORMANCE CURVES** ( $T_A = 25^\circ\text{C}$ )

**MAXIMUM FORWARD CURRENT vs. AMBIENT TEMPERATURE**

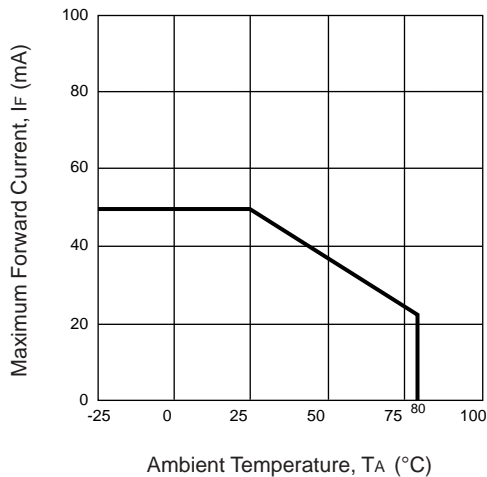

**MAXIMUM LOAD CURRENT vs. AMBIENT TEMPERATURE**

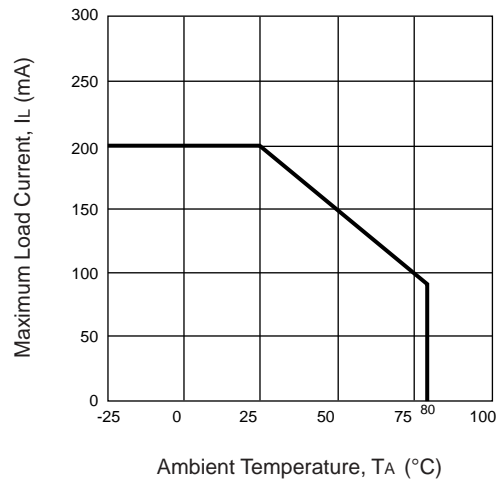

TYPICAL PERFORMANCE CURVES (TA = 25 °C)

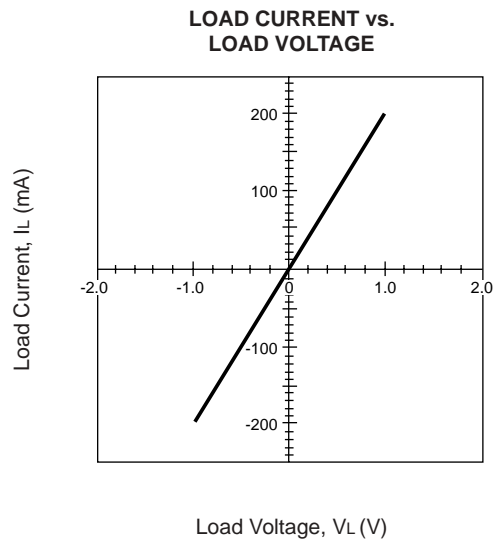
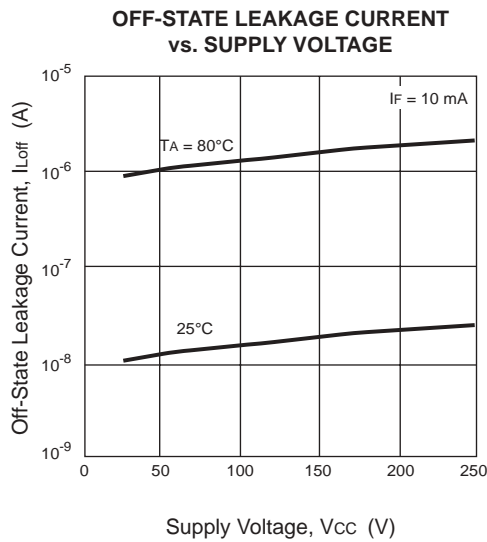
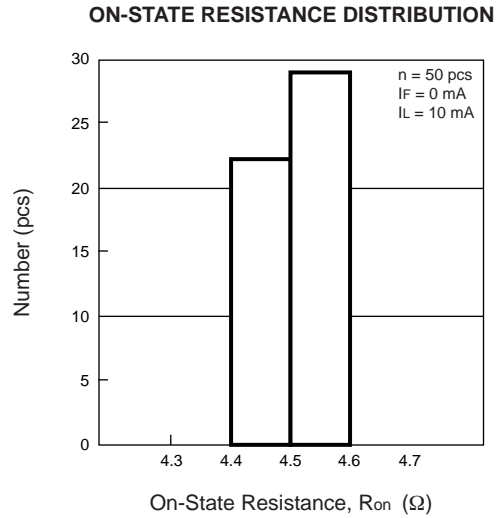
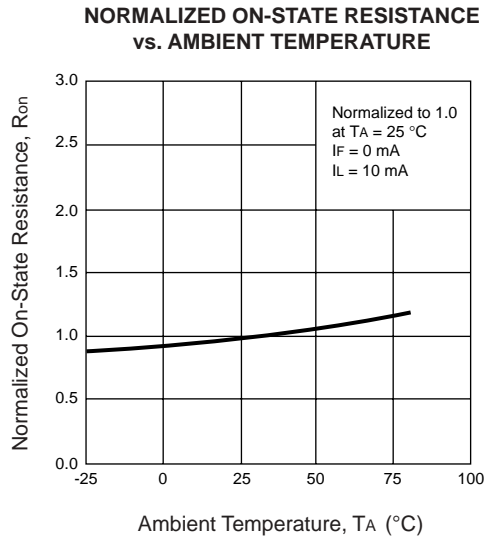
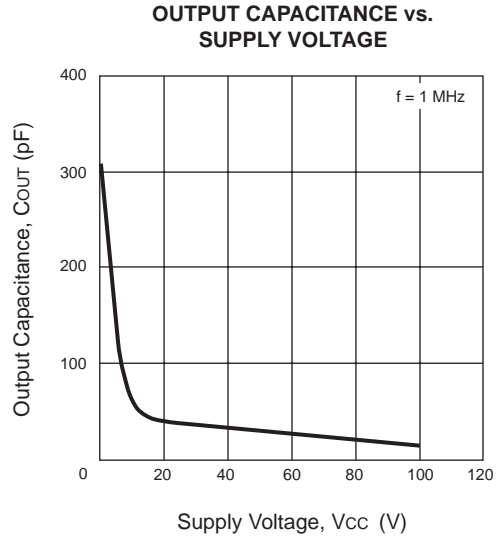
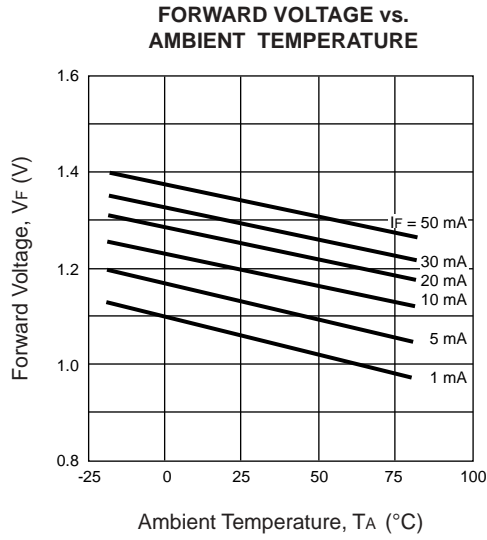

TYPICAL PERFORMANCE CURVES (TA = 25 °C)

TURN-ON TIME vs. FORWARD CURRENT

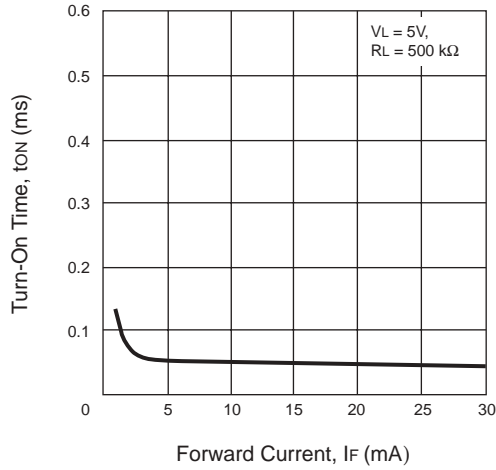

TURN-ON TIME DISTRIBUTION

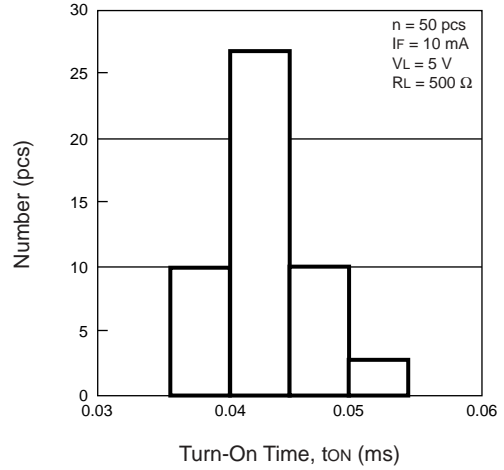

TURN-OFF TIME DISTRIBUTION

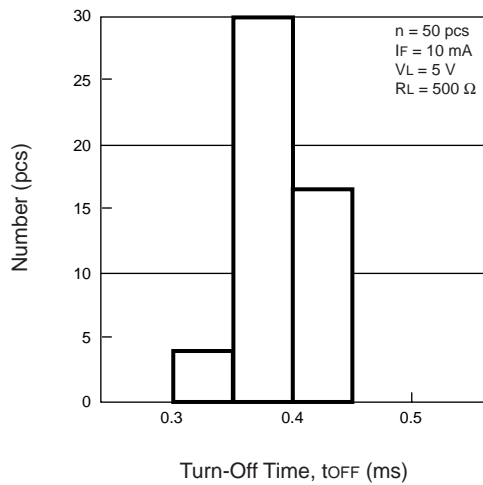

OFF-STATE LEAKAGE CURRENT vs. SUPPLY VOLTAGE

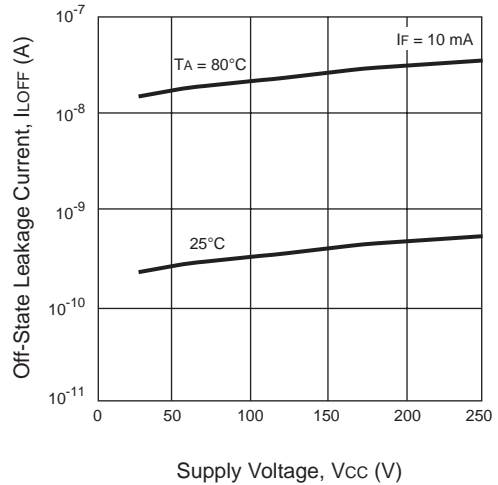

LOAD CURRENT vs. LOAD VOLTAGE

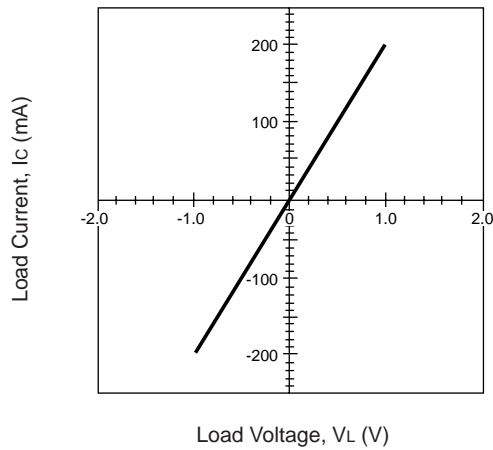

TURN-OFF TIME vs. FORWARD CURRENT

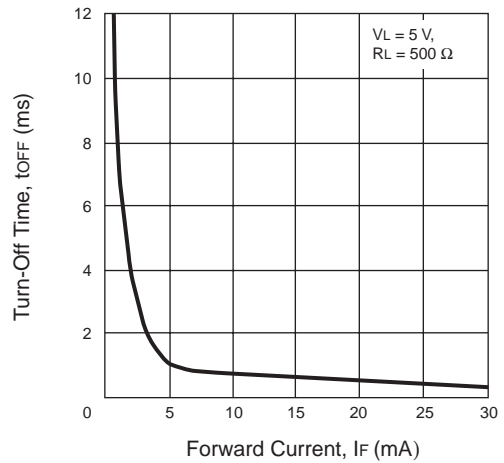

TYPICAL PERFORMANCE CURVES (TA = 25 °C)

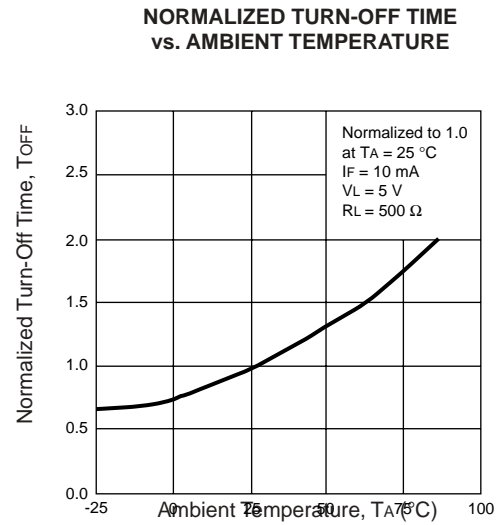
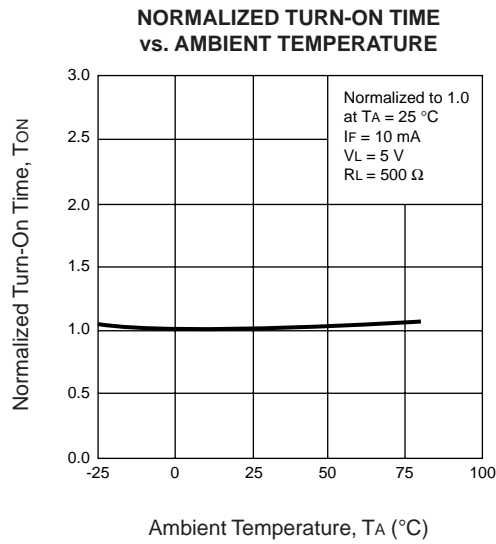

TAPING SPECIFICATIONS (Units in mm)

OUTLINE AND DIMENSIONS (TAPE)

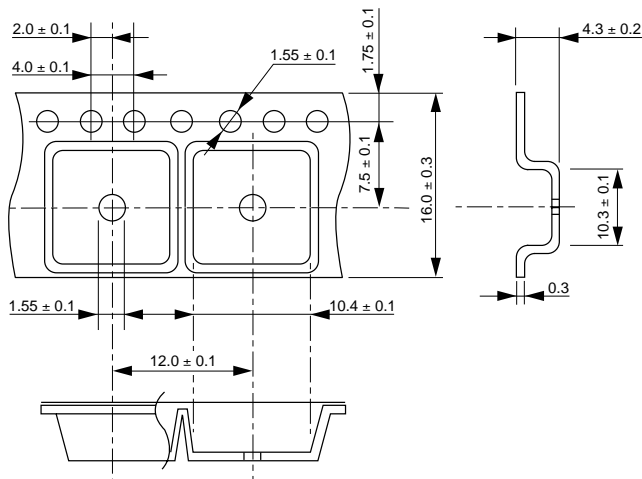

OUTLINE AND DIMENSIONS (REEL)

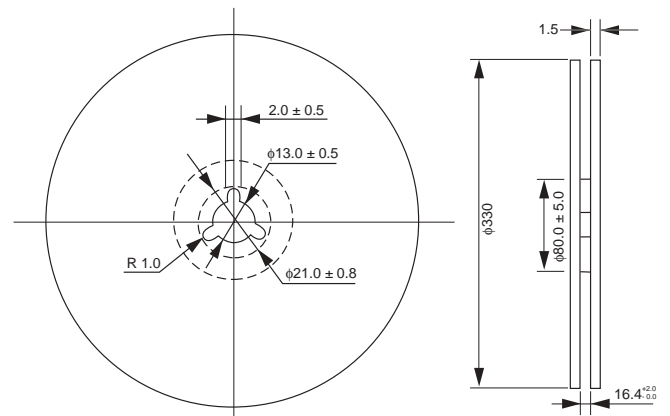

Notes:  
 1. Packing : 1000 pcs/reel

TAPING DIRECTION

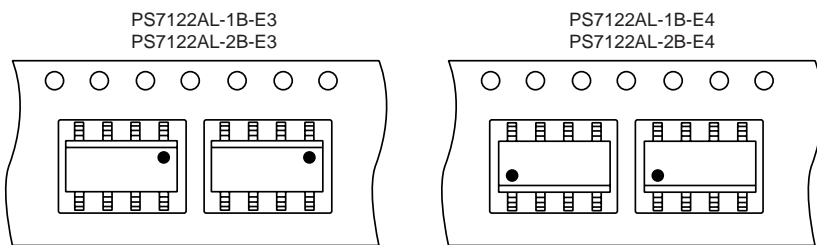

## RECOMMENDED SOLDERING CONDITIONS

### (1) Infrared reflow soldering

- Peak reflow temperature 235 °C or below (package surface temperature)
- Time of temperature higher than 210 °C 30 seconds or less
- Number of reflows Two
- Flux Rosin flux containing small amount of chlorine  
(The flux with a maximum chlorine content of 0.2 Wt % is recommended.)

Recommended Temperature Profile of Infrared Reflow

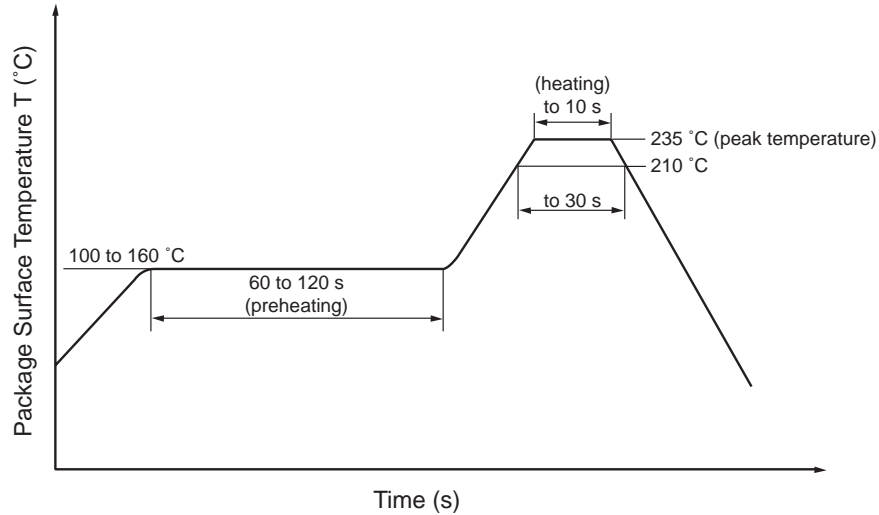

### (2) Dip soldering

- Temperature 260 °C or below (molten solder temperature)
- Time 10 seconds or less
- Number of times One
- Flux Rosin flux containing small amount of chlorine  
(The flux with a maximum chlorine content of 0.2 Wt % is recommended.)

### (3) Cautions

- Fluxes  
Avoid removing the residual flux with freon-based cleaning solvent.

EXCLUSIVE NORTH AMERICAN AGENT FOR **NEC** RF, MICROWAVE & OPTOELECTRONIC SEMICONDUCTORS

**CEL CALIFORNIA EASTERN LABORATORIES** • Headquarters • 4590 Patrick Henry Drive • Santa Clara, CA 95054-1817 • (408) 988-3500 • Telex 34-6393 • FAX (408) 988-0279  
24-Hour Fax-On-Demand: 800-390-3232 (U.S. and Canada only) • Internet: <http://WWW.CEL.COM>

DATA SUBJECT TO CHANGE WITHOUT NOTICE

07/17/2001