



The Future of Analog IC Technology™

EV7722DF-00C

20W Stereo Class D Single Ended Audio Amplifier

EVALUATION BOARD

DESCRIPTION

The EV7722DF-00C is the evaluation board for the MP7722. The MP7722 is a stereo 20W Class D Audio Amplifier. It is one of MPS' second generation of fully integrated audio amplifiers which dramatically reduces solution size by integrating the following:

- 180mΩ power MOSFETs
- Startup / Shutdown pop elimination
- Short circuit protection circuits
- Mute / Standby

The MP7722 utilizes a single ended output structure capable of delivering 2x20W into 4Ω speakers. MPS Class D Audio Amplifiers exhibit the high fidelity of a Class A/B amplifier at efficiencies greater than 90%. The circuit is based on the MPS' AAM™ proprietary variable frequency topology that delivers excellent linearity, fast response time and operates on a single power supply.

ELECTRICAL SPECIFICATIONS

Parameter	Symbol	Value	Units
Supply Voltage	V _{DD}	24	V

FEATURES

- 20W Output at V_{DD} = 24V into a 4Ω load
- THD+N = 0.06% at 1W, 8Ω
- 93% Efficiency at 20W
- Low Noise (190μV Typical)
- Switching Frequency Up to 1MHz
- 9.5V to 24V Operation from a Single Supply
- Mute/Standby Modes (Sleep)

APPLICATIONS

- Flat Panel and Projection Televisions
- DVD and Surround Sound Systems
- Flat Panel Monitors
- Multimedia Computers
- Home Stereo Systems

"MPS" and "The Future of Analog IC Technology" are Trademarks of Monolithic Power Systems, Inc.

AAM (Analog Adaptive Modulation) is a Trademark of Monolithic Power Systems, Inc.

EV7722DF-00C EVALUATION BOARD



(L x W x H) 3.5" x 2.4" x 1.2"
8.9cm x 6.1cm x 3.0cm

Board Number	MPS IC Number
EV7722DF-00C	MP7722DF

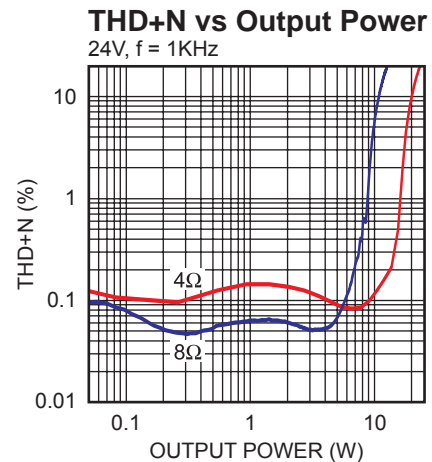

MP7722_TPC01

EVALUATION BOARD SCHEMATIC

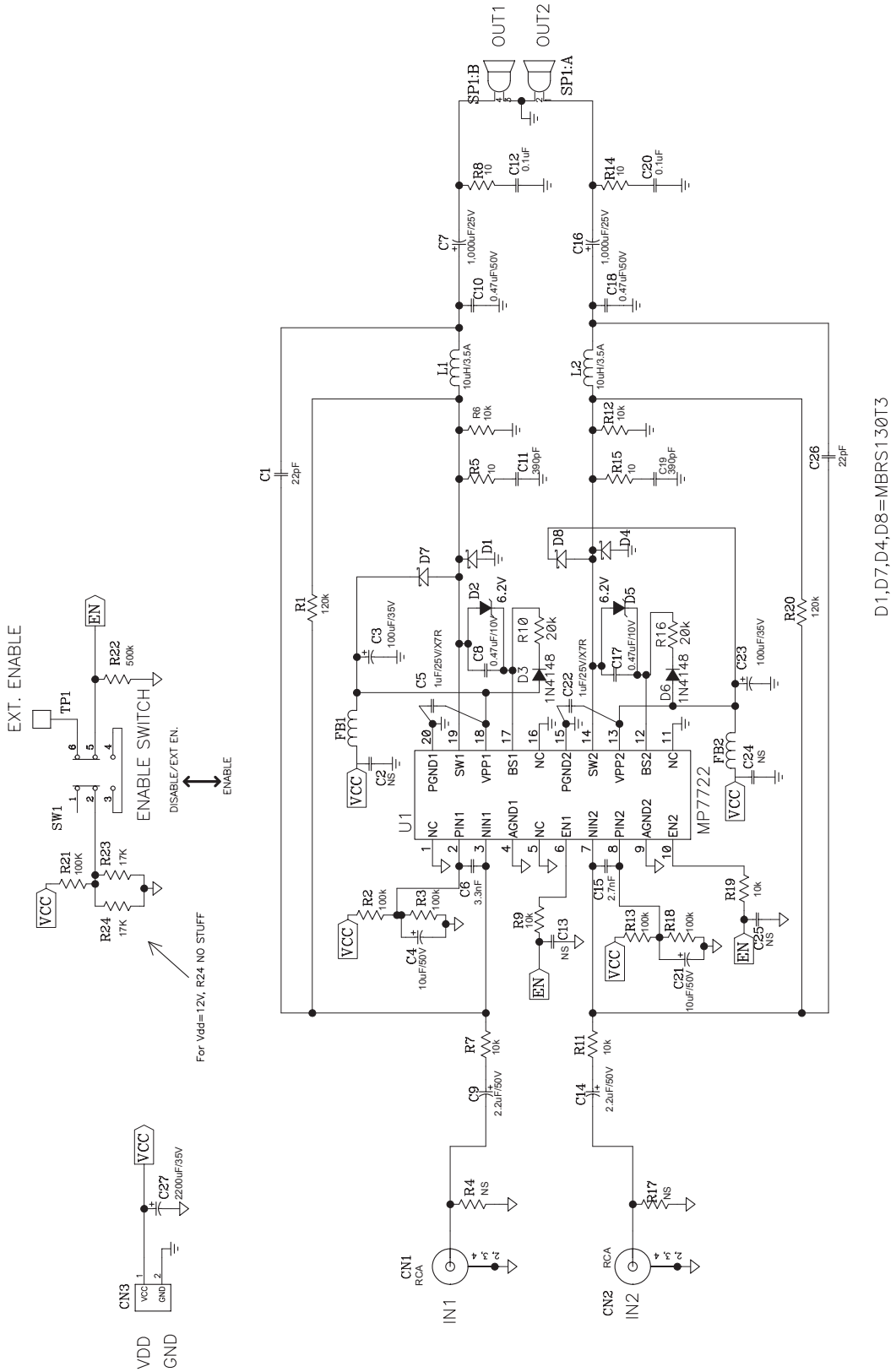

EV7722DF-00C BILL OF MATERIALS

Qty	Ref	Value	Description	Package	Manufacturer P/N	Digikey Part No.
2	C1, C26	22pF	Capacitor, 50V	0805	Panasonic: ECJ-2VC1H220J	PCC220CNCT-ND
4	C2, C13, C24, C25	NS				
2	C3, C23	100µF	Capacitor, 35V, ELECT FC RADIAL	Radial	Panasonic: EEU-FC1V101	P10294-ND
2	C4, C21	10µF	Capacitor, 50V, ELECT NHG	Radial	Panasonic: ECA-1HHG100	P5567-ND
2	C5, C22	1µF	Ceramic Capacitor, 25V, X7R	1206	Panasonic: ECJ-3YB1E105K	PCC1893CT-ND
1	C6	3.3nF	Ceramic Capacitor, 50V	0805	Panasonic ECJ-2VB1H332K	PCC332BNCT-ND
2	C7, C16	1000µF	Capacitor, 25V, ELECT NHG RADIAL	Radial	Panasonic: ECA-1EHG102	P5544-ND
2	C8, C17	0.47µF	Ceramic Capacitor, 16V, X7R	0805	Panasonic: ECJ-2YB1C474K	PCC1818CT-ND
2	C9, C14	2.2µF	Capacitor, 50V, ELECT NHG	Radial	Panasonic: ECA-1HHG2R2	P5564-ND
2	C10, C18	0.47µF	Capacitor, 50V, Stack Metal Film	Radial	Panasonic: ECQ-V1H474JL	P4671-ND
2	C11, C19	390pF	Capacitor, 50V	0805	Panasonic: ECU-V1H391KBN	PCC391BNCT-ND
2	C12, C20	0.1µF	Capacitor, 50V, X7R	1206	Panasonic: ECJ-3VB1H104K	PCC104BCT-ND
1	C15	2.7nF	Ceramic Capacitor, 50V	0805	Panasonic ECJ-2VB1H272K	PCC272BNCT-ND
1	C27	2200µF	Capacitor, 35V, ELECT NHG RADIAL	Radial	Panasonic ECA-1VHG222	P5556-ND
2	CN1, CN2		Phono Jack, Female	RCA Jack	Keystone: 901	901K-ND
1	CN3		Banana Jack Connector			
4	D1, D4, D7, D8		Diode Schottky, 30V, 1A	SMB	OnSemi: MBRS130T3	MBRS130T3OSCT-ND
2	D2, D5		Diode Zener, 6.2V 500mW	SOD-123	Diodes Inc: BZT52C6V2-7	BZT52C6V2-7DICT-ND
2	D3, D6		Diode Switch, 75V, 200MW	SOD-323	Diodes Inc: 1N4148WS-7	1N4148WSDICT-ND

EV7722DF-00C BILL OF MATERIALS (continued)

Qty	Ref	Value	Description	Package	Manufacturer P/N	Digikey Part No.
2	FB1, FB2		Ferrite, 6A, 50Ω	1206	Steward: HI1206T500R-00	240-1009-1-ND
2	L1, L2	10μH	Inductor, 3.5A, 13RHBP/IND	Radial	Toko: A7502HY-100M	
2	R1, R20	120kΩ	Resistor, 1/8W, 1%	SM0805	Yageo America: 9C08052A1203FKHFT	311-120KCCT-ND
4	R2, R3, R13, R18	100kΩ	Resistor, 1/8W, 1%	SM0805	Yageo America: 9C08052A1003FKHFT	311-100KCCT-ND
2	R4, R17	NS				
2	R5, R15	10Ω	Resistor, 1/8W, 1%	SM0805	Yageo America: 9C08052A10R0FKHFT	311-10.0CCT-ND
7	R6, R7, R9, R11, R12, R19, R22	10kΩ	Resistor, 1/8W, 1%	SM0805	Yageo America: 9C08052A1002FKHFT	311-10.0KCCT-ND
2	R8, R14	10Ω	Resistor, 1/4W, 1%	SM1206	Yageo America: 9C12063A10R0FKHFT	311-10.0FCT-ND
2	R10, R16	20kΩ	Resistor, 1/10W, 1%	SM0603	Yageo America: 9C06031A2002FKHFT	311-20.0KHCT-ND
1	R21	3kΩ	Resistor, 1/8W, 1%	SM0805	Yageo America 9C08052A3001FKHFT	311-3.00KCCT-ND
2	R23, R24	17kΩ	Resistor, 1/8W, 1%	SM0805	Yageo America: 9C08052A1004FKHFT	311-1.00MCCT-ND
1	SP1		Speaker Connector			
1	SW1		Switch Slide, DPDT, 12V, 0.1A, L=4		E-Switch: EG2209A	EG1908-ND
1	TP1		Test Point PC Mini, .040"D RED		Keystone: 5000	5000K-ND
1	U1		Amplifier	TSSOP20	MPS: MP7722	

TYPICAL PERFORMANCE CHARACTERISTICS

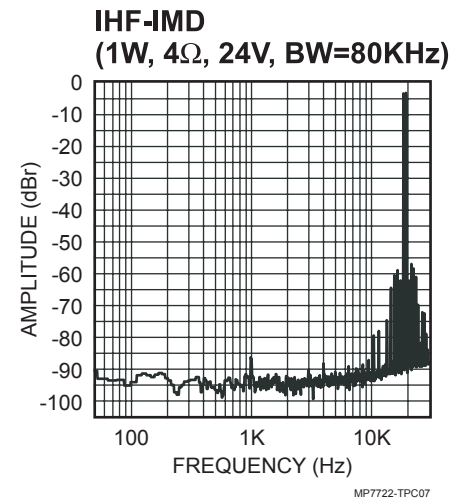
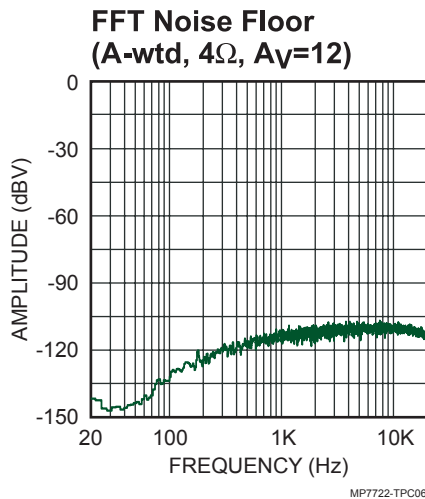
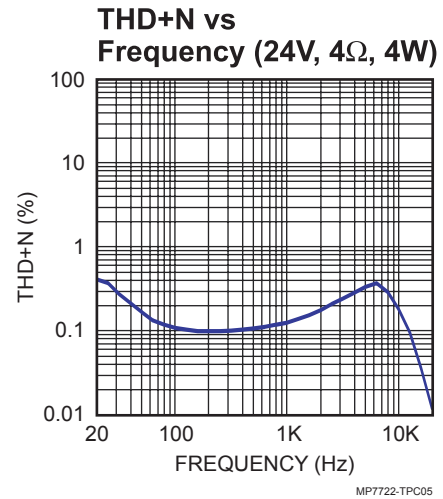
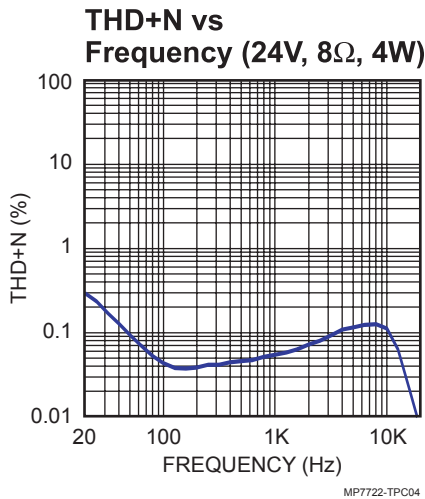
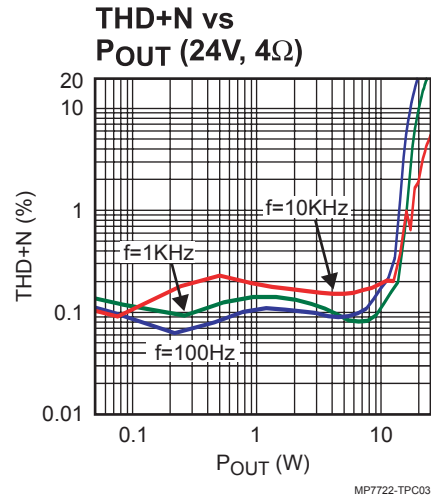
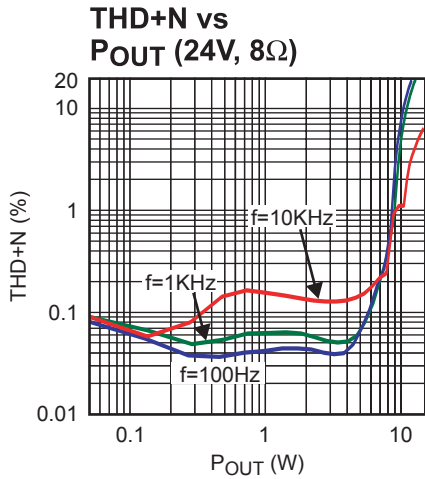

TYPICAL PERFORMANCE CHARACTERISTICS (continued)

Crosstalk/Separation vs. Frequency (24V, 5W, 4Ω)

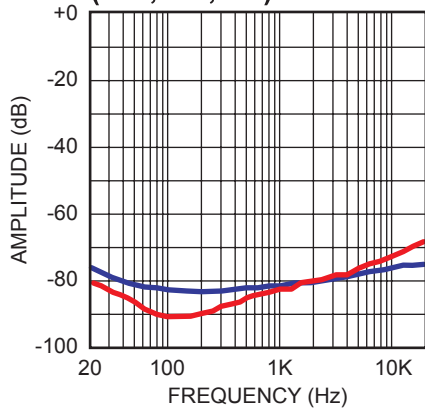

MP7722-TPC08

Frequency Response

0dBref = 4W, C_{IN} = 2.2μF,
R_{IN} = 10kΩ, C_{OUT} = 1000μF

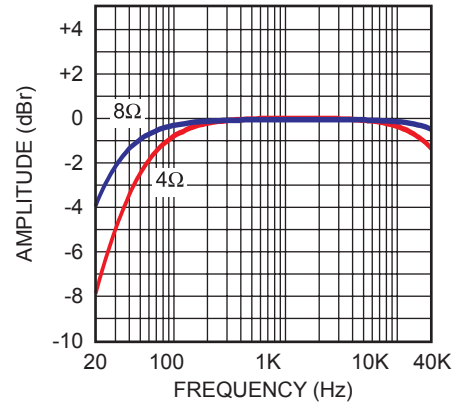

MP7722-TPC09

Efficiency vs P_{OUT}

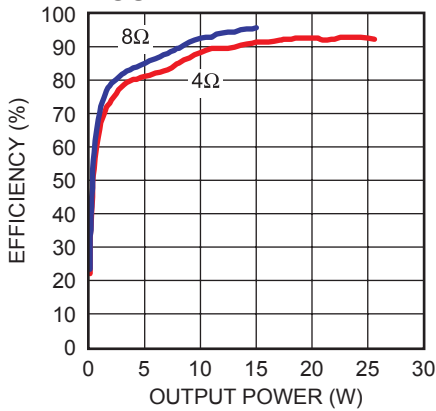

MP7722-TPC10

P_{OUT} vs V_{DD}

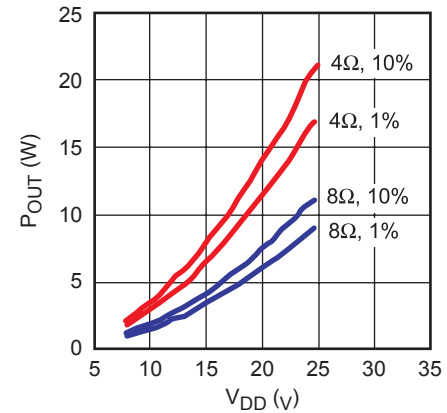

MP7722-TPC11

PRINTED CIRCUIT BOARD LAYOUT

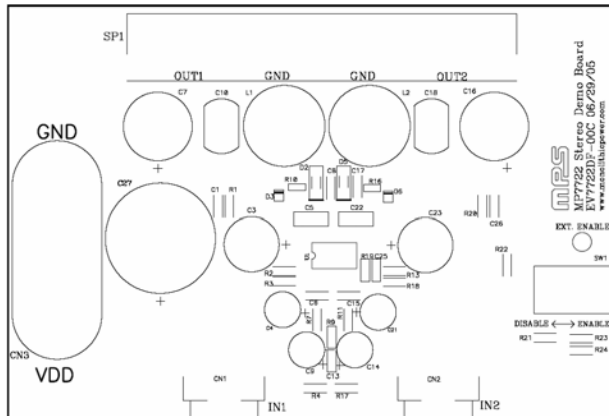

Figure 1—Top Silk Layer

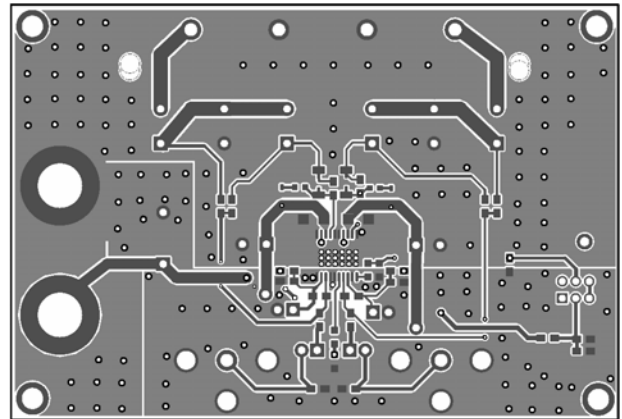

Figure 2—Top Layer

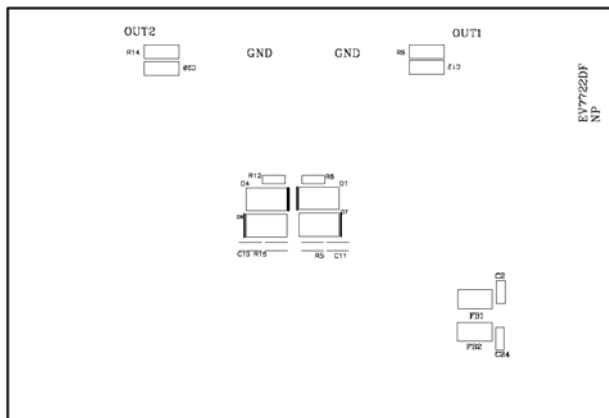

Figure 3—Bottom Silk Layer

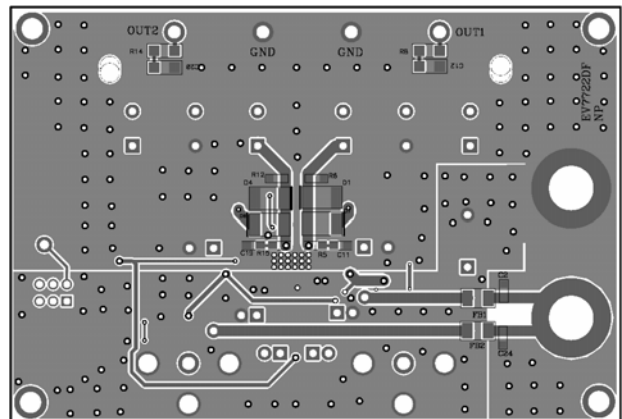

Figure 4—Bottom and Bottom Silk Layer

QUICK START GUIDE

Follow the instructions below for proper setup and operation. The EV board comes from the factory preconfigured for 24V operation. For 12V operation, R24 must first be removed, see Figure 5.

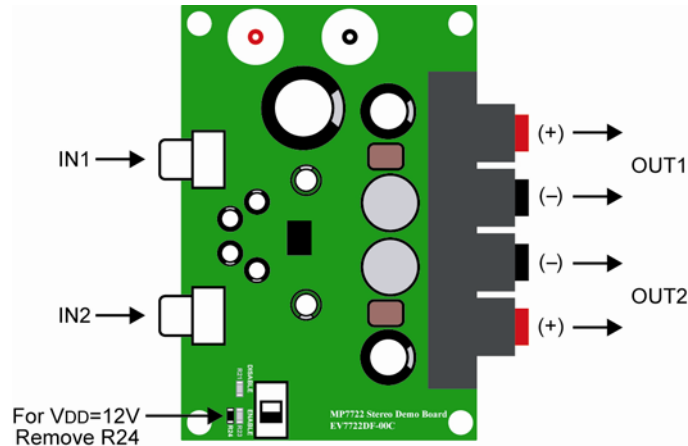

Figure 5—12V Operation

1. Power Requirements
 - a. Power supply: 15V to 24V, 3A maximum.
 - b. 0V to 1V_{RMS} (max) audio signal source, $\leq 600\Omega$.
 - c. Speaker: 4 Ω to 8 Ω .
2. Setup Condition for 24V Operation
 - a. Set the Enable switch to the DISABLE position.
 - b. Connect the audio input signal source to the amplifier inputs (IN1, IN2).
 - c. Connect the external speakers to the EVB Outputs.
 - d. **Before connecting power supply**, adjust the power supply to 24V DC (do not turn on).
 - e. Connect the power supply to the V_{DD} terminals.
 - f. Turn on the power supply to apply power to the board.
3. 12V Operation Modifications
 - a. Remove R24 from the demo board.
4. Music Turn-On Sequence
 - a. Set the enable switch to the ENABLE position.
 - b. Audio should be heard from the speaker(s).
5. Music Turn-Off Sequence
 - a. Set the enable switch to the DISABLE position.
 - b. Turn off power supply.

NOTICE: The information in this document is subject to change without notice. Please contact MPS for current specifications. Users should warrant and guarantee that third party Intellectual Property rights are not infringed upon when integrating MPS products into any application. MPS will not assume any legal responsibility for any said applications.