

ELECTRICAL SPECIFICATIONS:

- 1.0 TURNS RATIO: (P6-P5-P4) : (J6-J3) : 1CT : 1CT ± 3%
 (P3-P2-P1) : (J2-J1) : 1CT : 1CT ± 3%
- 2.0 INDUCTANCE: (P6-P4) : 350uH MIN. @ 0.1V, 100KHz, 8mA DC Bias
 (P3-P1) : 350uH MIN. @ 0.1V, 100KHz, 8mA DC Bias
- 3.0 LEAKAGE INDUCTANCE: P6-P4 (WITH J6 AND J3 SHORT) : 0.3 MAX. @ 1MHz
 P3-P1 (WITH J2 AND J1 SHORT) : 0.3 MAX. @ 1MHz
- 4.0 INTERWINDING CAPACITANCE: (P6,P5,P4) TO (J6,J3) : 30pf MAX @ 1MHz
 (P3,P2,P1) TO (J2,J1) : 30pf MAX. @ 1MHz
- 5.0 DC RESISTANCE: (J6-J3)=(J2-J1) : 1.2 ohms Max.

NOTES

1.0 PINS WITHOUT ELECTRICAL CONNECTION ARE OMITTED.

Bel Stewart Connector
 11118 Susquehanna Trail, South
 Glen Rock, Pa 17327-9199
 717.234.7512

MagJack®

<http://www.stewartconnector.com>

THIS DRAWING AND THE SUBJECT MATTER SHOWN THEREON ARE CONFIDENTIAL AND PROPERTY OF BEL STEWART CONNECTOR AND SHALL NOT BE REPRODUCED, COPIED, OR USED IN ANY MANNER WITHOUT PRIOR WRITTEN CONTENT OF BEL STEWART CONNECTOR. THE SUBJECT MATTER MAY BE PATENTED OR A PATENT MAY BE PENDING.

SHEET
1 OF 3

DRAWING NO. SI-46006

REV. A0

6.0 RETURN LOSS: $\langle P6-P4 \rangle = 100 \text{ OHMS}$ AND $\langle P1-P3 \rangle = 100 \text{ OHM REF.}$
 1MHz TO 30MHz : 18dB MIN.
 60MHz TO 80MHz : 12dB MIN.
 NOTE: 100 OHMS CONNECTED TO $\langle J2-J1 \rangle$ OR $\langle J6-J3 \rangle$.

7.0 VOLTAGE WITHSTAND:
 $\langle J1, J2 \rangle$ TO $\langle P1, P3 \rangle$: 1500 VAC
 $\langle J3, J6 \rangle$ TO $\langle P4, P6 \rangle$: 1500 VAC

8.0 INSERTION LOSS: $RS=RL=100 \text{ ohms}$
 100KHz TO 100MHz : 1.1 dB TYP

9.0 RISE TIME: $RS=100 \text{ OHMS}$ AND $RL = 100 \text{ OHMS}$
 OUTPUT VOLTAGE = 1 V peak : 3.0 nS MAX
 PULSE WIDTH= 112nS : 3.0 nS MAX

10.0 CROSS TALK:
 1MHz TO 100MHz : 40 dB TYP

11.0 COMMON TO COMMON MODE ATTENUATION:
 30MHz TO 100MHz : 35dB TYP

Bel Stewart Connector 11118 Susquehanna Trail, South Glen Rock, Pa 17327-9199 717.234.7512		 http://www.stewartconnector.com	
SHEET 2 OF 3	DRAWING NO. SI-46006	REV. A0	

THIS DRAWING AND THE SUBJECT MATTER SHOWN THEREON ARE CONFIDENTIAL AND PROPERTY OF BEL STEWART CONNECTOR AND SHALL NOT BE REPRODUCED, COPIED, OR USED IN ANY MANNER WITHOUT PRIOR WRITTEN CONTENT OF BEL STEWART CONNECTOR. THE SUBJECT MATTER MAY BE PATENTED OR A PATENT MAY BE PENDING.

LED POLARITY
(ENLARGED VIEW)

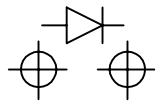

SINGLE COLOR LED

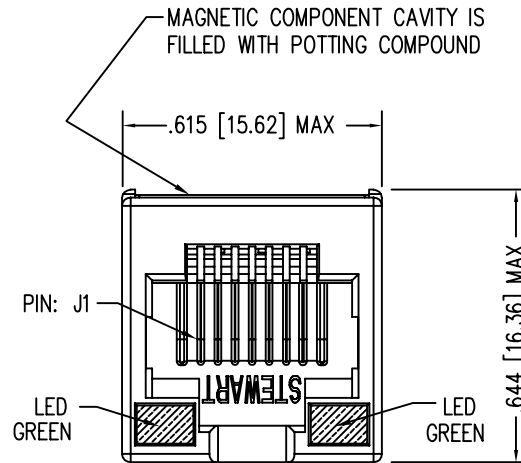
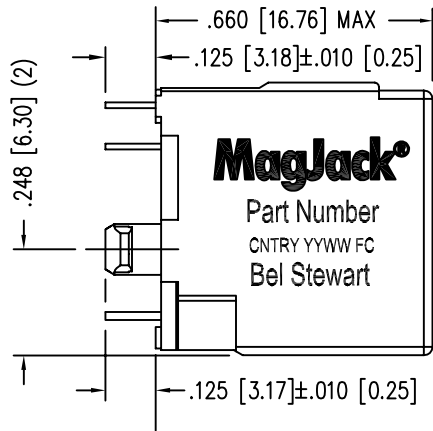

LED SPECIFICATIONS						
STANDARD LED	* FORWARD VOLTAGE (MAX)	* FORWARD VOLTAGE (TYP)	POWER DISSIPATION	WAVELENGTH	LUMINOUS INTENSITY @ 10mA	
					MIN	MAX
GREEN DIFFUSED	2.6 V	2.25 V	105 mW	555 nm	2 MCD	8 MCD

* WITH A FORWARD CURRENT OF 20 mA

(SIGNAL)
 $\phi .035 \pm .003 [0.89 \pm 0.08] (8)$
 $\phi \phi .006$

(POSTS) $\phi .128 [3.25]$
 $\phi .125 [3.18]$ (2)
 $\phi \phi .006$

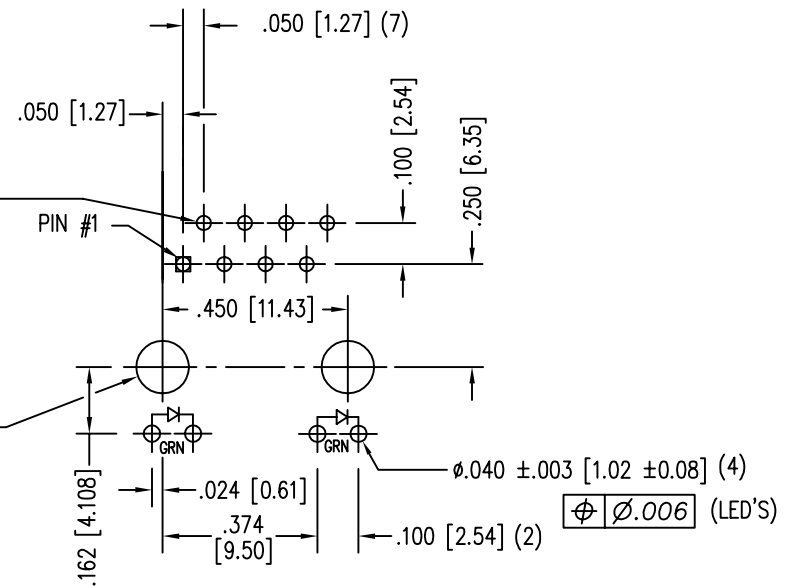

P.C.B. RECOMMENDED HOLE LAYOUT
SEEN FROM COMPONENT SIDE

ALL CENTERLINE DIMENSIONS ARE BASIC.

NOTES:

- CONNECTOR MATERIALS:
 HOUSING: THERMOPLASTIC UL94 V-0
 CONTACT: COPPER ALLOY
 CONTACT PLATING: SELECTIVE GOLD,
 50 MICRO-INCHES MIN. IN CONTACT AREA.
- PIN NOT ELECTRICALLY CONNECTED MAYBE OMITTED.
 SEE ELECTRICAL DRAWING FOR OMITTED PINS.
- TOLERANCES COMPLY WITH F.C.C. DIMENSION REQUIREMENTS.
- ALL TOLERANCES NOT OTHERWISE SPECIFIED TO BE $\pm .005 [0.13]$
- WAVE SOLDER COMPATIBLE - PREHEAT 125°C/90SECS.

Bel Stewart Connector
 11118 Susquehanna Trail, South
 Glen Rock, Pa 17327-9199
 717.234.7512

MagJack[®]

<http://www.stewartconnector.com>

THIS DRAWING AND THE SUBJECT MATTER SHOWN THEREON ARE CONFIDENTIAL AND PROPERTY OF BEL STEWART CONNECTOR AND SHALL NOT BE REPRODUCED, COPIED, OR USED IN ANY MANNER WITHOUT PRIOR WRITTEN CONTENT OF BEL STEWART CONNECTOR. THE SUBJECT MATTER MAY BE PATENTED OR A PATENT MAY BE PENDING.

SHEET
3 OF 3

DRAWING NO.
SI-46006

REV.
A0