

**7020X Series Surface Mount LEDs**

**DESCRIPTION AND FEATURES**

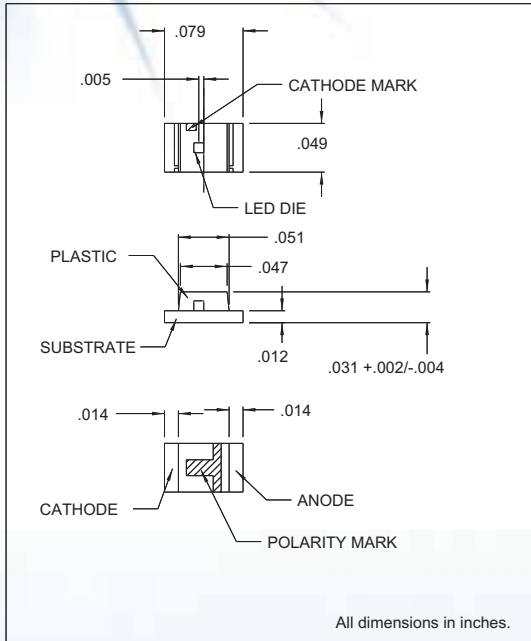

**Surface Mount Technology**

- Tape and reel packaged for high-speed autoinsertion.
- Convection and vapor-phase reflow compatible.
- Compact form enables high density placement.
- Packaged 4000 pieces per reel.

**Leading Edge LED Optoelectronic Performance**

- Consistent high brightness.

**Exceptional Reliability**

- Stringent process controls assure quality.
- Extensive qualification testing to meet strictest requirements.
- Designed to permit easy post-reflow solder joint inspection.

- Solder pad geometry on page 1-X1.

**ELECTRO-OPTICAL CHARACTERISTICS AND RATINGS**

PART NUMBER	7020X1	7020X3	7020X5	7020X7	7020X15	7020X21	7020X23	7020X33
Output Color	Red	Orange	Green	Yellow	Green	Red	Orange	Yellow
Diffusion	Diffused	Diffused	Diffused	Diffused	Diffused	Diffused	Diffused	Diffused
Package Color	Clear	Clear	Clear	Clear	Clear	Clear	Clear	Clear
Test Current (mA)	20	20	20	20	20	20	20	20
Forward Voltage Typ. (V)	1.7	2.2	2.1	2.2	2.1	1.9	1.9	1.9
Forward Voltage Max. (V)	2.3	2.8	2.8	2.8	2.8	2.4	2.4	2.4
Luminous Intensity Min. (mcd)	7.0	2.2	3.8	2.2	1.6	16.0	16.0	16.0
Luminous Intensity Typ. (mcd)	11.7	3.7	6.4	3.7	2.7	50.0	65.0	65.0
Luminous Intensity Max. (mcd)	-	-	-	-	-	-	-	-
Peak Wavelength (nm)	660	605	560	580	555	630	609	592
Viewing Angle 2θ 1/2 (degrees)	140	140	140	140	140	140	140	140
Power Dissipation (mW)	57.5	70	70	70	70	81	81	81
Operating Temperature (°C)	-30 to +85	-30 to +85	-30 to +85	-30 to +85	-30 to +85	-40 to +85	-40 to +85	-40 to +85
Storage Temperature (°C)	-40 to +100	-40 to +100	-40 to +100	-40 to +100	-40 to +100	-40 to +100	-40 to +100	-40 to +100
Peak Forward Current Max. (1µs @ 10% duty cycle) (mA)	60	60	60	60	60	100	100	100
Reverse Voltage (IR=100µA) (V)	4	4	4	4	4	5	5	5
Lead Solder Time @ 260°C	5	5	5	5	5	5	5	5