

Document Title

64Kx36-Bit Synchronous Burst SRAM

Revision History

<u>Rev. No.</u>	<u>History</u>	<u>Draft Date</u>	<u>Remark</u>
0.0	Initial draft	July. 03. 1998	Preliminary
0.1	Change DC Characteristics. Icc value from 320mA to 250mA at -7. Icc value from 300mA to 230mA at -8. Icc value from 280mA to 200mA at -9. Ise value from 90mA to 70mA at -7. Ise value from 80mA to 60mA at -8. Ise value from 70mA to 50mA at -9. Ise1 value from 30mA to 20mA Ise2 value from 30mA to 20mA	Sep. 14. 1998	Preliminary
1.0	Final spec release.	Nov. 16. 1998	Final
2.0	Add VDDQ Supply voltage(2.5V)	Dec. 02. 1998	Final
3.0	Min tOH Parameter Change : from 2.0ns to 3.0ns Min tLZC Parameter Change : from 0ns to 3ns	Dec. 17. 1998	Final

The attached data sheets are prepared and approved by SAMSUNG Electronics. SAMSUNG Electronics CO., LTD. reserve the right to change the specifications. SAMSUNG Electronics will evaluate and reply to your requests and questions on the parameters of this device. If you have any questions, please contact the SAMSUNG branch office near your office, call or contact Headquarters.

64Kx36-Bit Synchronous Burst SRAM

FEATURES

- Synchronous Operation.
- On-Chip Address Counter.
- Write Self-Timed Cycle.
- On-Chip Address and Control Registers.
- $V_{DD} = 3.3V \pm 0.3V / -0.165V$ Power Supply.
- V_{DDQ} Supply Voltage $3.3V \pm 0.3V / -0.165V$ for 3.3V I/O or $2.5V \pm 0.4V / -0.125V$ for 2.5V I/O.
- 5V Tolerant Inputs except I/O Pins.
- Byte Writable Function.
- Global Write Enable Controls a full bus-width write.
- Power Down State via ZZ Signal.
- Asynchronous Output Enable Control.
- \overline{ADSP} , \overline{ADSC} , \overline{ADV} Burst Control Pins.
- LBO Pin allows a choice of either a interleaved burst or a linear burst.
- Three Chip Enables for simple depth expansion with No Data Contention.
- TTL-Level Three-State Output.
- 100-TQFP-1420A

GENERAL DESCRIPTION

The KM736V687A is 2,359,296 bits Synchronous Static Random Access Memory designed to support zero wait state performance for advanced Pentium/Power PC based system. And with $\overline{CS1}$ high, \overline{ADSP} is blocked to control signals. It can be organized as 64K words of 36 bits. And it integrates address and control registers, a 2-bit burst address counter and high output drive circuitry onto a single integrated circuit for reduced components counts implementation of high performance cache RAM applications. Write cycles are internally self-timed and synchronous. The self-timed write feature eliminates complex off chip write pulse shaping logic, simplifying the cache design and further reducing the component count. Burst cycle can be initiated with either the address status processor (\overline{ADSP}) or address status cache controller (\overline{ADSC}) inputs. Subsequent burst addresses are generated internally in the system's burst sequence and are controlled by the burst address advance (\overline{ADV}) input. ZZ pin controls Power Down State and reduces Stand-by current regardless of CLK. The KM736V687A is implemented with SAMSUNG's high performance CMOS technology and is available in a 100pin TQFP package. Multiple power and ground pins are utilized to minimize ground bounce.

FAST ACCESS TIMES

PARAMETER	Symbol	-7	-8	-9	Unit
Cycle Time	t _{CYC}	8.5	10	12	ns
Clock Access Time	t _{CD}	7.5	8	9	ns
Output Enable Access Time	t _{OE}	3.5	3.5	3.5	ns

LOGIC BLOCK DIAGRAM

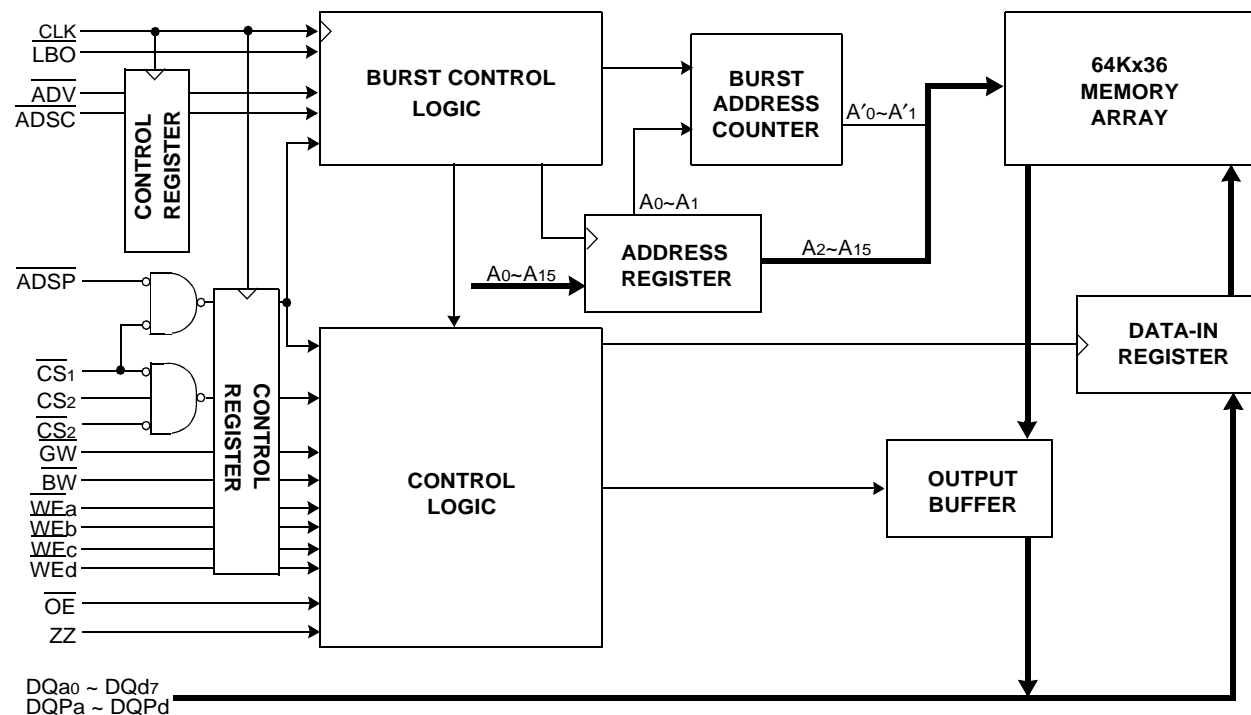

PIN CONFIGURATION(TOP VIEW)

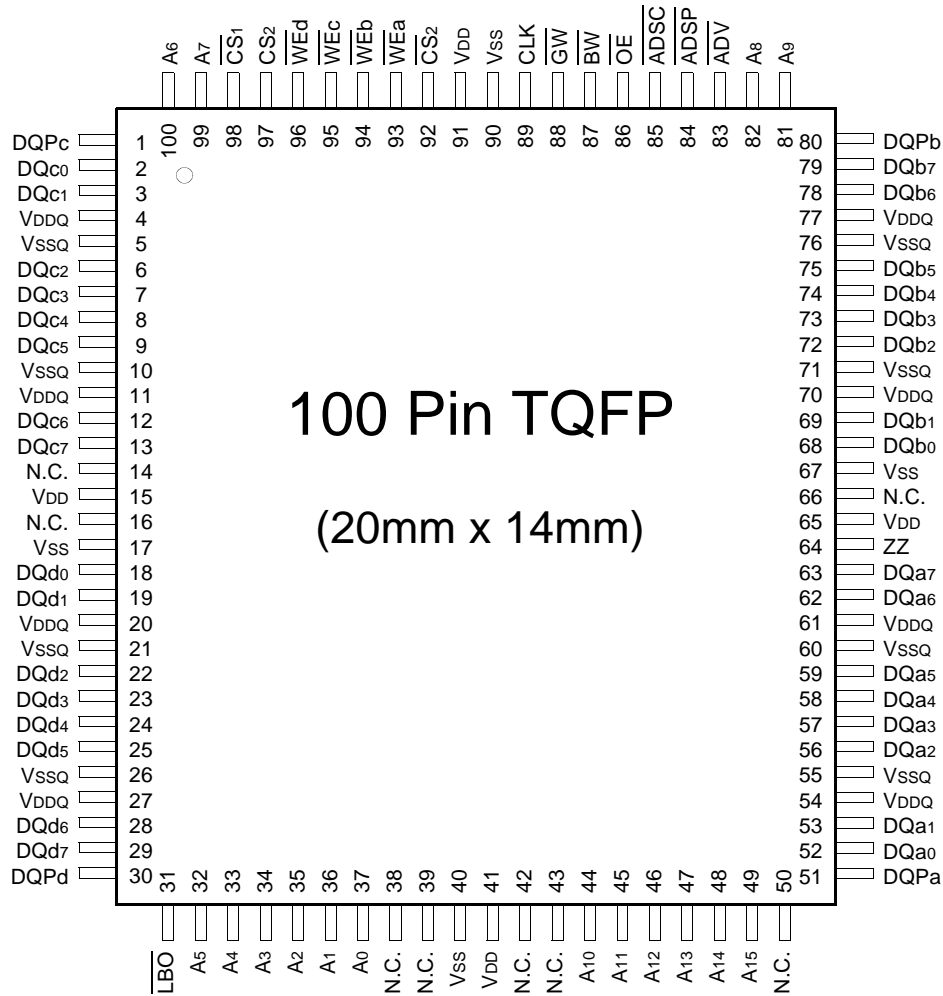

PIN NAME

SYMBOL	PIN NAME	TQFP PIN NO.	SYMBOL	PIN NAME	TQFP PIN NO.
A0 - A15	Address Inputs	32,33,34,35,36,37,44,45,46,47,48,49,81,82,99,100	VDD	Power Supply(+3.3V)	15,41,65,91
			VSS	Ground	17,40,67,90
			N.C.	No Connect	14,16,38,39,42,43,50,66
ADV	Burst Address Advance	83	DQa0~a7	Data Inputs/Outputs	52,53,56,57,58,59,62,63
ADSP	Address Status Processor	84	DQb0~b7		68,69,72,73,74,75,78,79
ADSC	Address Status Controller	85	DQc0~c7		2,3,6,7,8,9,12,13
CLK	Clock	89	DQd0~d7		18,19,22,23,24,25,28,29
CS1	Chip Select	98	DQPa~Pd		51,80,1,30
CS2	Chip Select	97			
CS2	Chip Select	92			
WE _x	Byte Write Inputs	93,94,95,96	VDDQ	Output Power Supply (2.5V or 3.3V)	4,11,20,27,54,61,70,77
OE	Output Enable	86	VSSQ	Output Ground	5,10,21,26,55,60,71,76
GW	Global Write Enable	88			
BW	Byte Write Enable	87			
ZZ	Power Down Input	64			
LBO	Burst Mode Control	31			

FUNCTION DESCRIPTION

The KM736V687A is a synchronous SRAM designed to support the burst address accessing sequence of the Pentium and Power PC based microprocessor. All inputs (with the exception of OE, LBO and ZZ) are sampled on rising clock edges. The start and duration of the burst access is controlled by ADSC, ADSP and ADV and chip select pins.

When ZZ is pulled high, the SRAM will enter a Power Down State. At this time, internal state of the SRAM is preserved. When ZZ returns to low, the SRAM normally operates after 2cycles of wake up time. ZZ pin is pulled down internally.

Read cycles are initiated with ADSP(or ADSC) using the new external address clocked into the on-chip address register when both GW and BW are high or when BW is low and WEa, WEb, WEc, and WEd are high. When ADSP is sampled low, the chip selects are sampled active, and the output buffer is enabled with OE. the data of cell array accessed by the current address are projected to the output pins.

Write cycles are also initiated with ADSP(or ADSC) and are differentiated into two kinds of operations; All byte write operation and individual byte write operation.

All byte write occurs by enabling GW(independent of BW and WEx.), and individual byte write is performed only when GW is high and BW is low. In KM736V687A, a 64Kx36 organization, WEa controls DQa0 ~ DQa7 and DQPa, WEb controls DQb0 ~ DQb7 and DQPb, WEc controls DQc0 ~ DQc7 and DQPc and WEd controls DQd0 ~ DQd7 and DQPd.

CS1 is used to enable the device and conditions internal use of ADSP and is sampled only when a new external address is loaded.

ADV is ignored at the clock edge when ADSP is asserted, but can be sampled on the subsequent clock edges. The address increases internally for the next access of the burst when ADV is sampled low.

Addresses are generated for the burst access as shown below, The starting point of the burst sequence is provided by the external address. The burst address counter wraps around to its initial state upon completion. The burst sequence is determined by the state of the LBO pin. When this pin is Low, linear burst sequence is selected. And this pin is High, Interleaved burst sequence is selected.

BURST SEQUENCE TABLE

(Interleaved Burst)

LBO PIN	HIGH	Case 1		Case 2		Case 3		Case 4	
		A1	A0	A1	A0	A1	A0	A1	A0
	First Address	0	0	0	1	1	0	1	1
	↓	0	1	0	0	1	1	1	0
	↓	1	0	1	1	0	0	0	1
	Fourth Address	1	1	1	0	0	1	0	0

(Linear Burst)

LBO PIN	LOW	Case 1		Case 2		Case 3		Case 4	
		A1	A0	A1	A0	A1	A0	A1	A0
	First Address	0	0	0	1	1	0	1	1
	↓	0	1	1	0	1	1	0	0
	↓	1	0	1	1	0	0	0	1
	Fourth Address	1	1	0	0	0	1	1	0

Note : 1. LBO pin must be tied to high or low, and floating state must not be allowed.

ASYNCHRONOUS TRUTH TABLE

(See Notes 1 and 2):

OPERATION	ZZ	OE	I/O STATUS
Sleep Mode	H	X	High-Z
Read	L	L	DQ
	L	H	High-Z
Write	L	X	Din, High-Z
Deselected	L	X	High-Z

Notes

1. X means "Don't Care".
2. ZZ pin is pulled down internally
3. For write cycles that following read cycles, the output buffers must be disabled with OE, otherwise data bus contention will occur.
4. Sleep Mode means power down state of which stand-by current does not depend on cycle time.
5. Deselected means power down state of which stand-by current depends on cycle time.

SYNCHRONOUS TRUTH TABLE

\overline{CS}_1	\overline{CS}_2	\overline{CS}_2	\overline{ADSP}	\overline{ADS}	\overline{ADV}	\overline{WRITE}	CLK	ADDRESS ACCESSED	Operation
H	X	X	X	L	X	X	↑	N/A	Not Selected
L	L	X	L	X	X	X	↑	N/A	Not Selected
L	X	H	L	X	X	X	↑	N/A	Not Selected
L	L	X	X	L	X	X	↑	N/A	Not Selected
L	X	H	X	L	X	X	↑	N/A	Not Selected
L	H	L	L	X	X	X	↑	External Address	Begin Burst Read Cycle
L	H	L	H	L	X	L	↑	External Address	Begin Burst Write Cycle
L	H	L	H	L	X	H	↑	External Address	Begin Burst Read Cycle
X	X	X	H	H	L	H	↑	Next Address	Continue Burst Read Cycle
H	X	X	X	H	L	H	↑	Next Address	Continue Burst Read Cycle
X	X	X	H	H	L	L	↑	Next Address	Continue Burst Write Cycle
H	X	X	X	H	L	L	↑	Next Address	Continue Burst Write Cycle
X	X	X	H	H	H	H	↑	Current Address	Suspend Burst Read Cycle
H	X	X	X	H	H	H	↑	Current Address	Suspend Burst Read Cycle
X	X	X	H	H	H	L	↑	Current Address	Suspend Burst Write Cycle
H	X	X	X	H	H	L	↑	Current Address	Suspend Burst Write Cycle

- Notes : 1. X means "Don't Care".
 2. The rising edge of clock is symbolized by ↑.
 3. $\overline{WRITE} = L$ means Write operation in WRITE TRUTH TABLE.
 $\overline{WRITE} = H$ means Read operation in WRITE TRUTH TABLE.
 4. Operation finally depends on status of asynchronous input pins(ZZ and \overline{OE}).

WRITE TRUTH TABLE

\overline{GW}	\overline{BW}	\overline{WEa}	\overline{WEb}	\overline{WEc}	\overline{WEd}	OPERATION
H	H	X	X	X	X	READ
H	L	H	H	H	H	READ
H	L	L	H	H	H	WRITE BYTE a
H	L	H	L	H	H	WRITE BYTE b
H	L	H	H	L	L	WRITE BYTE c and d
H	L	L	L	L	L	WRITE ALL BYTES
L	X	X	X	X	X	WRITE ALL BYTES

- Notes : 1. X means "Don't Care".
 2. All inputs in this table must meet setup and hold time around the rising edge of CLK(↑).

ABSOLUTE MAXIMUM RATINGS*

PARAMETER	SYMBOL	RATING	UNIT
Voltage on VDD Supply Relative to VSS	VDD	-0.3 to 4.6	V
Voltage on VDDQ Supply Relative to VSS	VDDQ	VDD	V
Voltage on Input Pin Relative to VSS	VIN	-0.3 to 6.0	V
Voltage on I/O Pin Relative to VSS	VIO	-0.3 to VDDQ + 0.5	V
Power Dissipation	Pd	1.2	W
Storage Temperature	TSTG	-65 to 150	°C
Operating Temperature	TOPR	0 to 70	°C
Storage Temperature Range Under Bias	TBIAS	-10 to 85	°C

*Notes : Stresses greater than those listed under "Absolute Maximum Ratings" may cause permanent damage to the device. This is a stress rating only and functional operation of the device at these or any other conditions above those indicated in the operating sections of this specification is not implied. Exposure to absolute maximum rating conditions for extended periods may affect reliability.

OPERATING CONDITIONS at 3.3V I/O (0°C ≤ TA ≤ 70°C)

PARAMETER	SYMBOL	MIN	Typ.	MAX	UNIT
Supply Voltage	VDD	3.135	3.3	3.6	V
	VDDQ	3.135	3.3	3.6	V
Ground	VSS	0	0	0	V

OPERATING CONDITIONS at 2.5V I/O (0°C ≤ TA ≤ 70°C)

PARAMETER	SYMBOL	MIN	Typ.	MAX	UNIT
Supply Voltage	VDD	3.135	3.3	3.6	V
	VDDQ	2.375	2.5	2.9	V
Ground	VSS	0	0	0	V

CAPACITANCE* (TA=25°C, f=1MHz)

PARAMETER	SYMBOL	TEST CONDITION	MIN	MAX	UNIT
Input Capacitance	CIN	VIN=0V	-	5	pF
Output Capacitance	COUT	VOUT=0V	-	7	pF

*Note : Sampled not 100% tested.

DC ELECTRICAL CHARACTERISTICS($T_A=0$ to 70°C , $V_{DD}=3.3\text{V}+0.3\text{V}/-0.165\text{V}$)

PARAMETER	SYMBOL	TEST CONDITIONS	MIN	MAX	UNIT	
Input Leakage Current(except ZZ)	IIL	$V_{DD}=\text{Max}$, $V_{IN}=V_{SS}$ to V_{DD}	-2	+2	μA	
Output Leakage Current	IOL	Output Disabled, $V_{OUT}=V_{SS}$ to V_{DDQ}	-2	+2	μA	
Operating Current	ICC	Device Selected, $I_{OUT}=0\text{mA}$, $ZZ \leq V_{IL}$, All Inputs= V_{IL} or V_{IH} Cycle Time $\geq t_{CYC}$ min	-7	-	250	mA
			-8	-	230	
			-9	-	200	
Standby Current	ISB	Device deselected, $I_{OUT}=0\text{mA}$, $ZZ \leq V_{IL}$, $f=\text{Max}$, All Inputs $\leq 0.2\text{V}$ or $\geq V_{DD}-0.2\text{V}$	-7	-	70	mA
			-8	-	60	
			-9	-	50	
	ISB1	Device deselected, $I_{OUT}=0\text{mA}$, $ZZ \leq 0.2\text{V}$, $f=0$, All Inputs=fixed ($V_{DD}-0.2\text{V}$ or 0.2V)	-	-	20	mA
ISB2	Device deselected, $I_{OUT}=0\text{mA}$, $ZZ \geq V_{DD}-0.2\text{V}$, $f=\text{Max}$, All Inputs $\leq V_{IL}$ or $\geq V_{IH}$	-	-	20	mA	
Output Low Voltage(3.3V I/O)	VOL	$I_{OL} = 8.0\text{mA}$	-	0.4	V	
Output High Voltage(3.3V I/O)	VOH	$I_{OH} = -4.0\text{mA}$	2.4	-	V	
Output Low Voltage(2.5V I/O)	VOL	$I_{OL} = 1.0\text{mA}$	-	0.4	V	
Output High Voltage(2.5V I/O)	VOH	$I_{OH} = -1.0\text{mA}$	2.0	-	V	
Input Low Voltage(3.3V I/O)	VIL		-0.5*	0.8	V	
Input High Voltage(3.3V I/O)	VIH		2.0	$V_{DD}+0.5^{**}$	V	
Input Low Voltage(2.5V I/O)	VIL		-0.3*	0.7	V	
Input High Voltage(2.5V I/O)	VIH		1.7	$V_{DD}+0.5^{**}$	V	

* $V_{IL}(\text{Min})=-2.0(\text{Pulse Width} \leq t_{CYC}/2)$

** $V_{IH}(\text{Max})=4.6(\text{Pulse Width} \leq t_{CYC}/2)$

** In Case of I/O Pins, the Max. $V_{IH}=V_{DDQ}+0.5\text{V}$

TEST CONDITIONS

($V_{DD}=3.3\text{V}+0.3\text{V}/-0.165\text{V}$, $V_{DDQ}=3.3\text{V}+0.3\text{V}/-0.165\text{V}$ or $V_{DD}=3.3\text{V}+0.3\text{V}/-0.165\text{V}$, $V_{DDQ}=2.5\text{V}+0.4\text{V}/-0.125\text{V}$, $T_A=0$ to 70°C)

PARAMETER	VALUE
Input Pulse Level(for 3.3V I/O)	0 to 3V
Input Pulse Level(for 2.5V I/O)	0 to 2.5V
Input Rise and Fall Time(Measured at 0.3V and 2.7V for 3.3V I/O)	1ns
Input Rise and Fall Time(Measured at 0.3V and 2.1V for 2.5V I/O)	1ns
Input and Output Timing Reference Levels for 3.3V I/O	1.5V
Input and Output Timing Reference Levels for 2.5V I/O	$V_{DDQ}/2$
Output Load	See Fig. 1

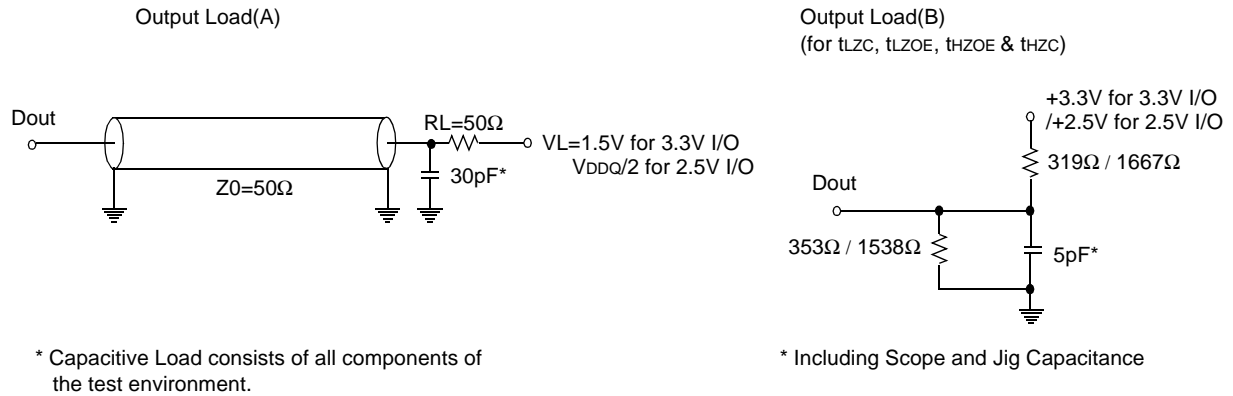

Fig. 1

AC TIMING CHARACTERISTICS (TA=0 to 70°C, VDD=3.3V+0.3V/-0.165V)

PARAMETER	SYMBOL	KM736V687A-7		KM736V687A-8		KM736V687A-9		UNIT
		MIN	MAX	MIN	MAX	MIN	MAX	
Cycle Time	tCYC	8.5	-	10	-	12	-	ns
Clock Access Time	tCD	-	7.5	-	8	-	9	ns
Output Enable to Data Valid	toE	-	3.5	-	3.5	-	3.5	ns
Clock High to Output Low-Z	tLZC	3	-	3	-	3	-	ns
Output Hold from Clock High	toH	3	-	3	-	3	-	ns
Output Enable Low to Output Low-Z	tLZOE	0	-	0	-	0	-	ns
Output Enable High to Output High-Z	tHZOE	-	3.5	-	3.5	-	3.5	ns
Clock High to Output High-Z	tHZC	2	3.5	2	3.5	2	3.5	ns
Clock High Pulse Width	tCH	3	-	4	-	4.5	-	ns
Clock Low Pulse Width	tCL	3	-	4	-	4.5	-	ns
Address Setup to Clock High	tAS	2.0	-	2.0	-	2.0	-	ns
Address Status Setup to Clock High	tSS	2.0	-	2.0	-	2.0	-	ns
Data Setup to Clock High	tDS	2.0	-	2.0	-	2.0	-	ns
Write Setup to Clock High(\overline{GW} , \overline{BW} , \overline{WEx})	tWS	2.0	-	2.0	-	2.0	-	ns
Address Advance Setup to Clock High	tADVS	2.0	-	2.0	-	2.0	-	ns
Chip Select Setup to Clock High	tCSS	2.0	-	2.0	-	2.0	-	ns
Address Hold from Clock High	tAH	0.5	-	0.5	-	0.5	-	ns
Address Status Hold from Clock High	tSH	0.5	-	0.5	-	0.5	-	ns
Data Hold from Clock High	tDH	0.5	-	0.5	-	0.5	-	ns
Write Hold from Clock High(\overline{GW} , \overline{BW} , \overline{WEx})	tWH	0.5	-	0.5	-	0.5	-	ns
Address Advance Hold from Clock High	tADVH	0.5	-	0.5	-	0.5	-	ns
Chip Select Hold from Clock High	tCSH	0.5	-	0.5	-	0.5	-	ns
ZZ High to Power Down	tPDS	2	-	2	-	2	-	cycle
ZZ Low to Power Up	tPUS	2	-	2	-	2	-	cycle

- Notes :
1. All address inputs must meet the specified setup and hold times for all rising clock edges whenever \overline{ADSC} and/or \overline{ADSP} is sampled low and \overline{CS} is sampled low. All other synchronous inputs must meet the specified setup and hold times whenever this device is chip selected.
 2. Both chip selects must be active whenever \overline{ADSC} or \overline{ADSP} is sampled low in order for the this device to remain enabled.
 3. \overline{ADSC} or \overline{ADSP} must not be asserted for at least 2 Clock after leaving ZZ state.
 4. At any given voltage and temperature, t_{hzc} is less than t_{lzc}.

TIMING WAVEFORM OF READ CYCLE

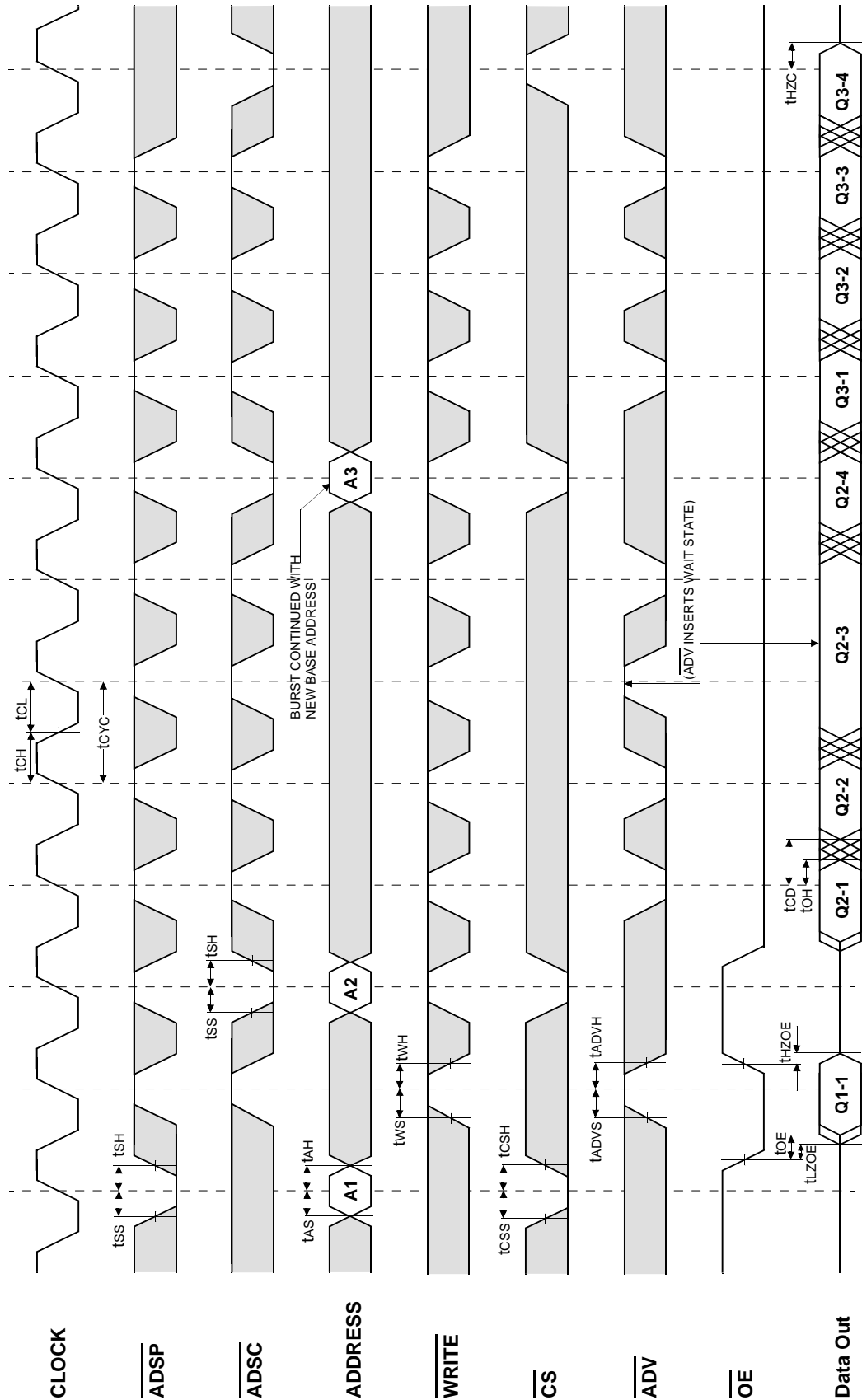

Don't Care
 Undefined

NOTES : $\overline{WRITE} = L$ means $\overline{GW} = L$, or $\overline{GW} = H$, $\overline{BW} = L$, $\overline{WE} = L$
 $\overline{CS} = L$ means $\overline{CS}_1 = L$, $\overline{CS}_2 = H$ and $\overline{CS}_2 = L$
 $\overline{CS} = H$ means $\overline{CS}_1 = H$, or $\overline{CS}_1 = L$ and $\overline{CS}_2 = H$, or $\overline{CS}_1 = L$, and $\overline{CS}_2 = L$

TIMING WAVEFORM OF WRTE CYCLE

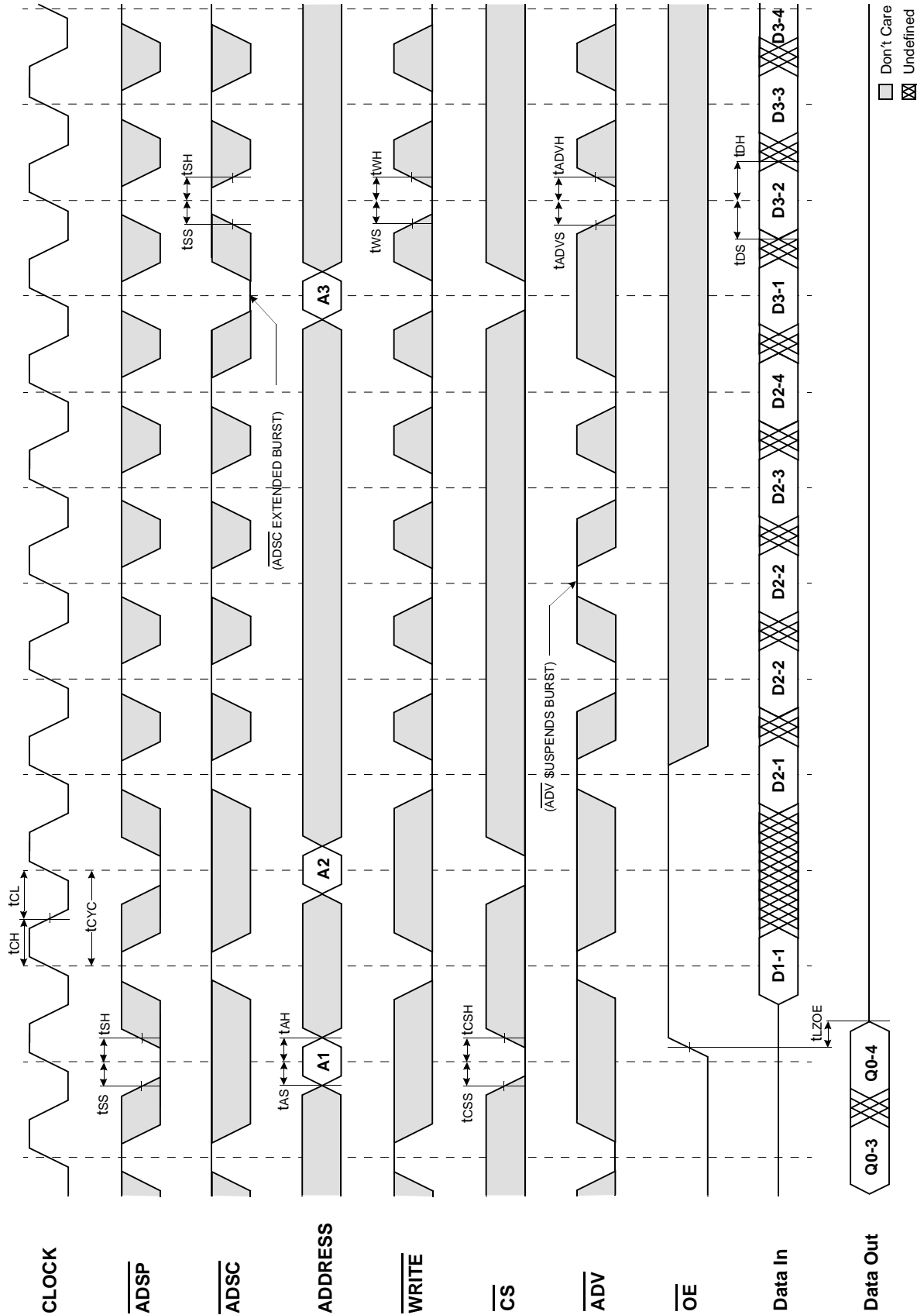

TIMING WAVEFORM OF COMBINATION READ/WRITE CYCLE(ADSP CONTROLLED, $\overline{\text{ADSC}}=\text{HIGH}$)

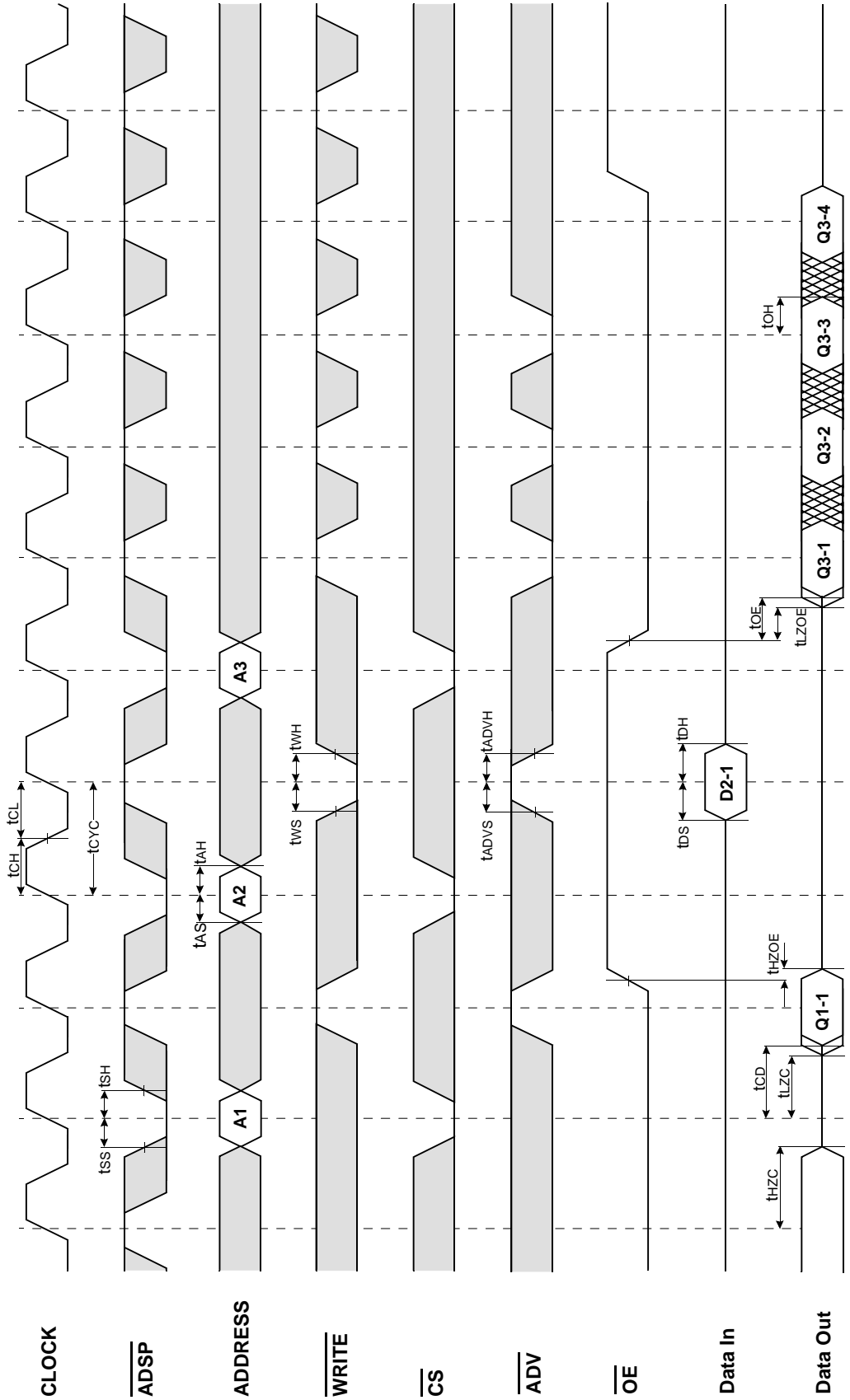

Don't Care
 Undefined

TIMING WAVEFORM OF SINGLE READ/WRITE CYCLE (ADSC CONTROLLED, ADSP=HIGH)

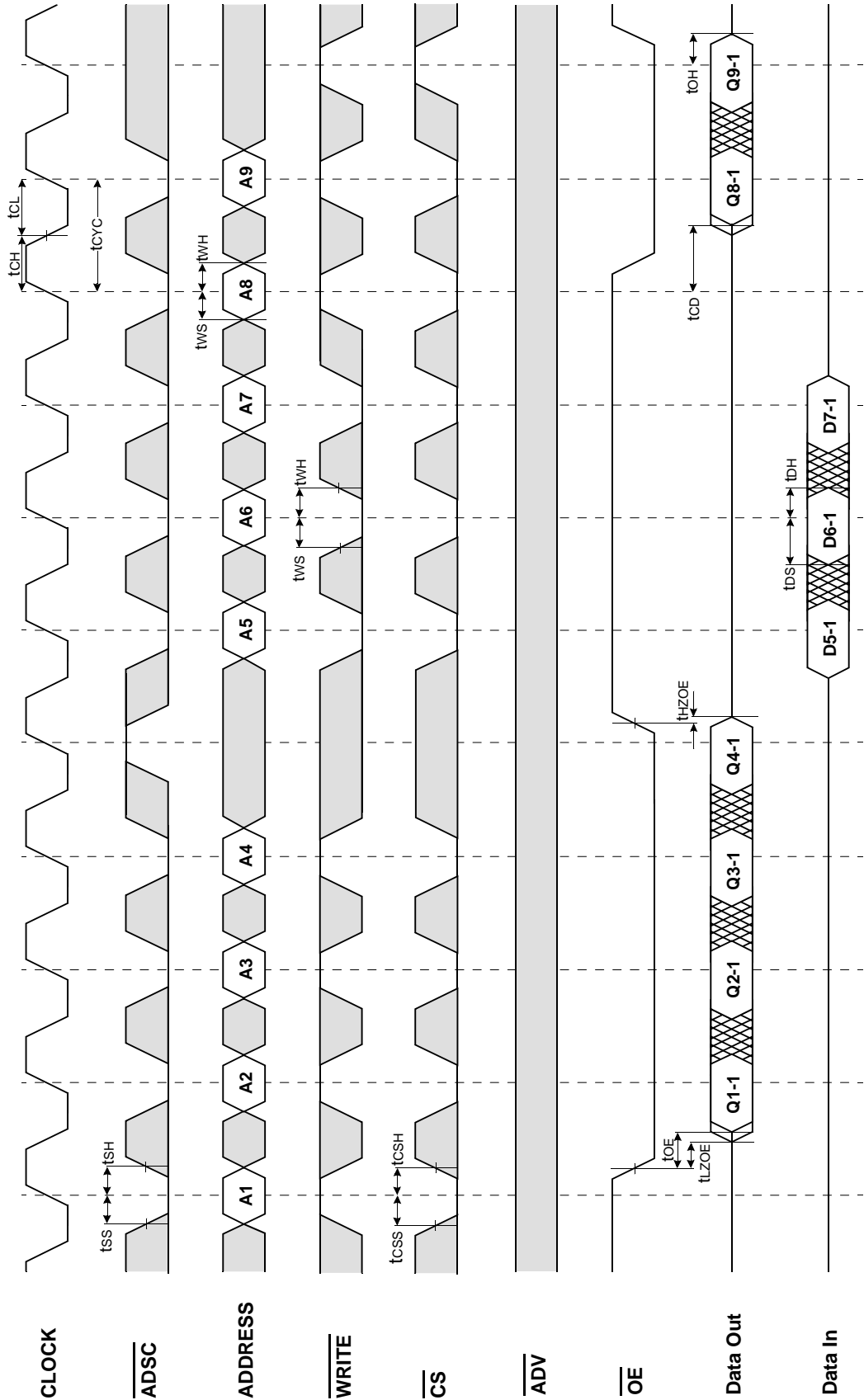

Don't Care
 Undefined

TIMING WAVEFORM OF SINGLE READ/WRITE CYCLE(ADSP CONTROLLED, ADSC=HIGH)

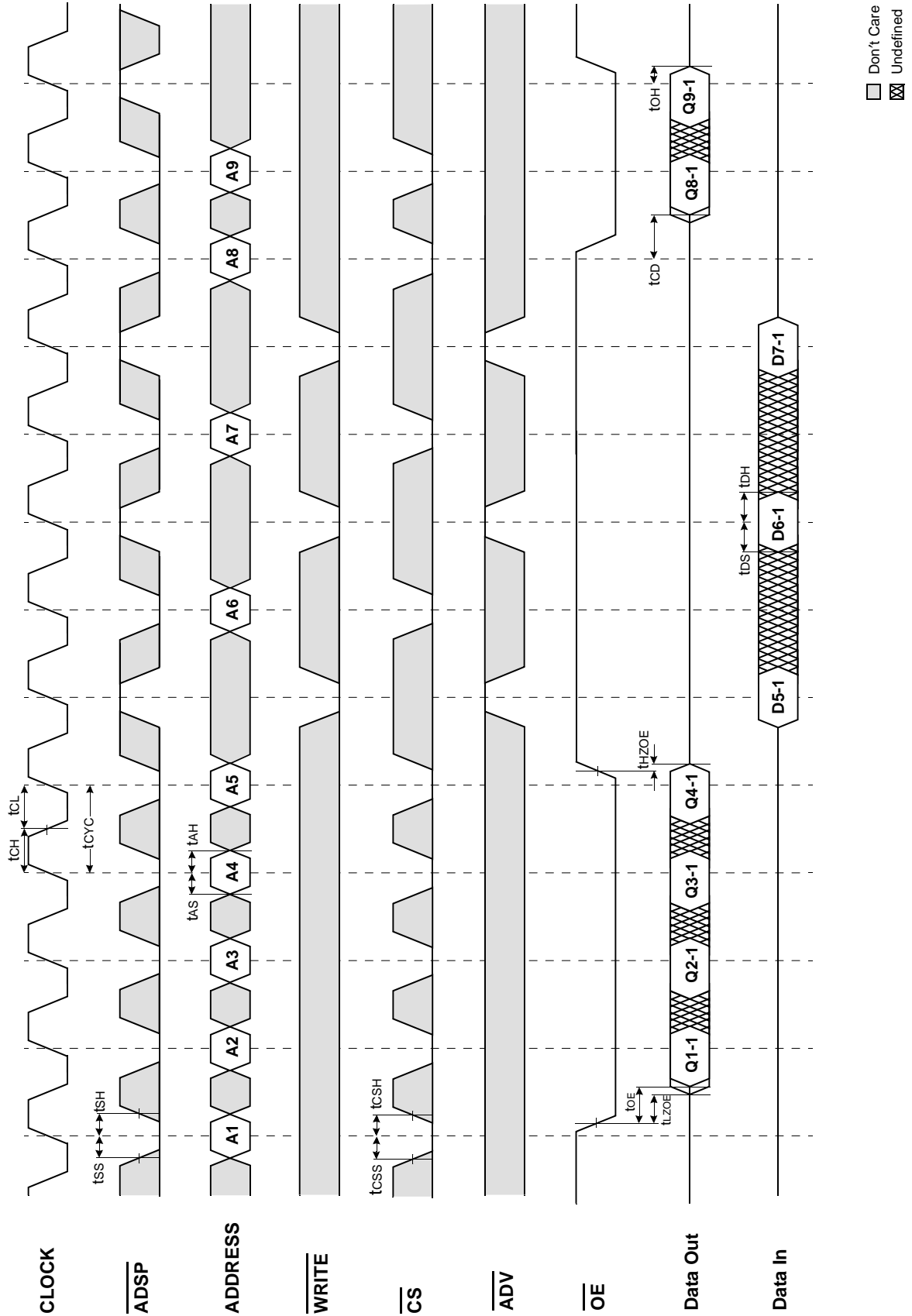

TIMING WAVEFORM OF POWER DOWN CYCLE

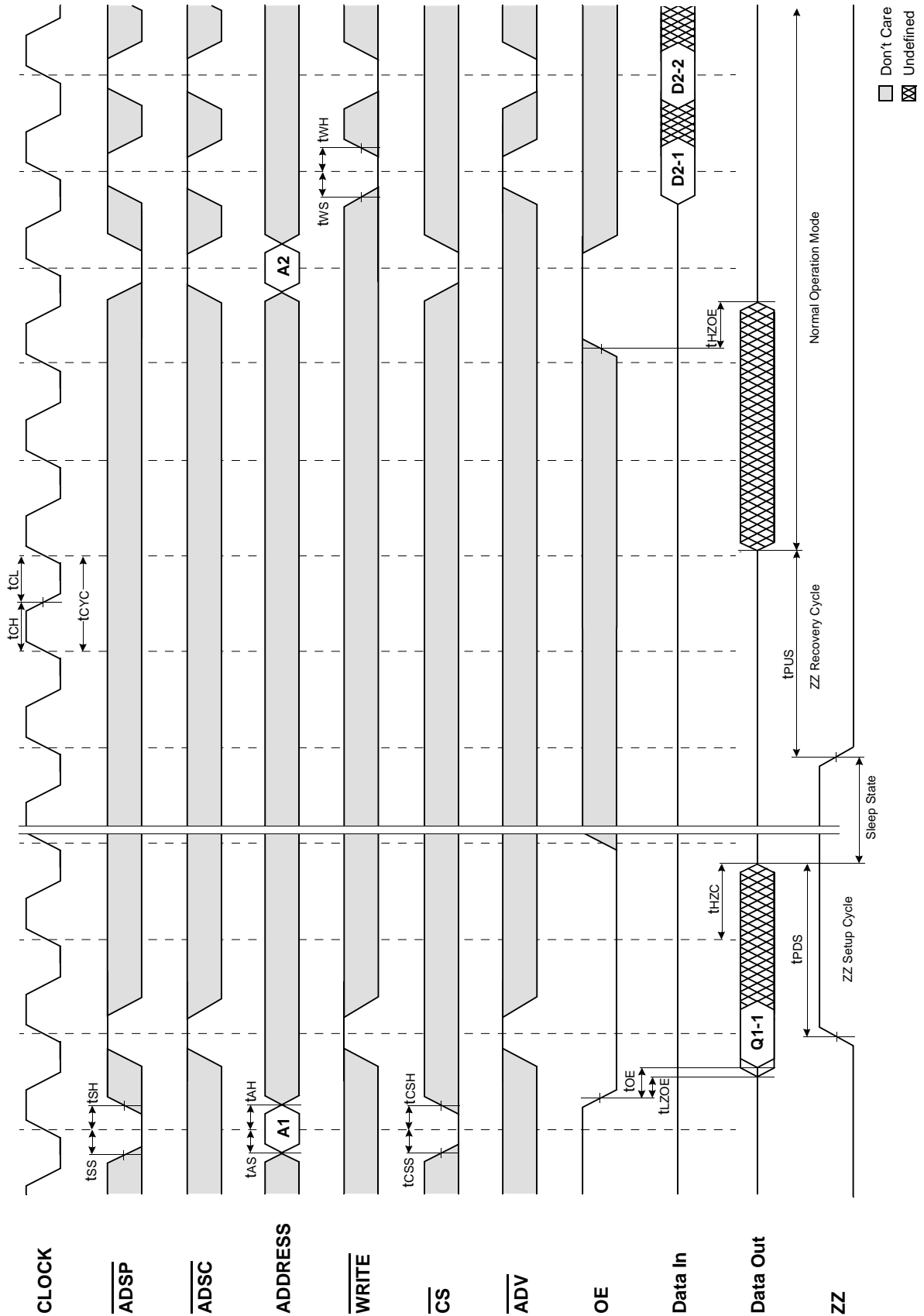

□ Don't Care
 ⊠ Undefined

APPLICATION INFORMATION

DEPTH EXPANSION

The Samsung 64Kx36 Synchronous Burst SRAM has two additional chip selects for simple depth expansion. This permits easy secondary cache upgrades from 64K depth to 128K depth without extra logic.

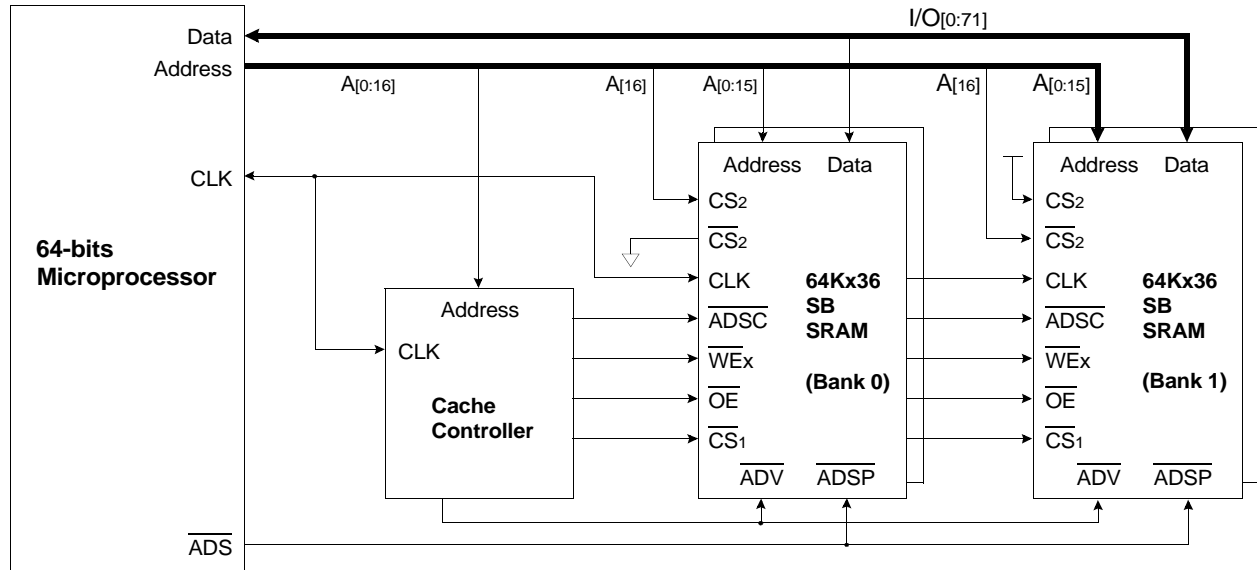

INTERLEAVE READ TIMING (Refer to non-interleave write timing for interleave write timing)

(\overline{ADSC} CONTROLLED, \overline{ADSC} =HIGH)

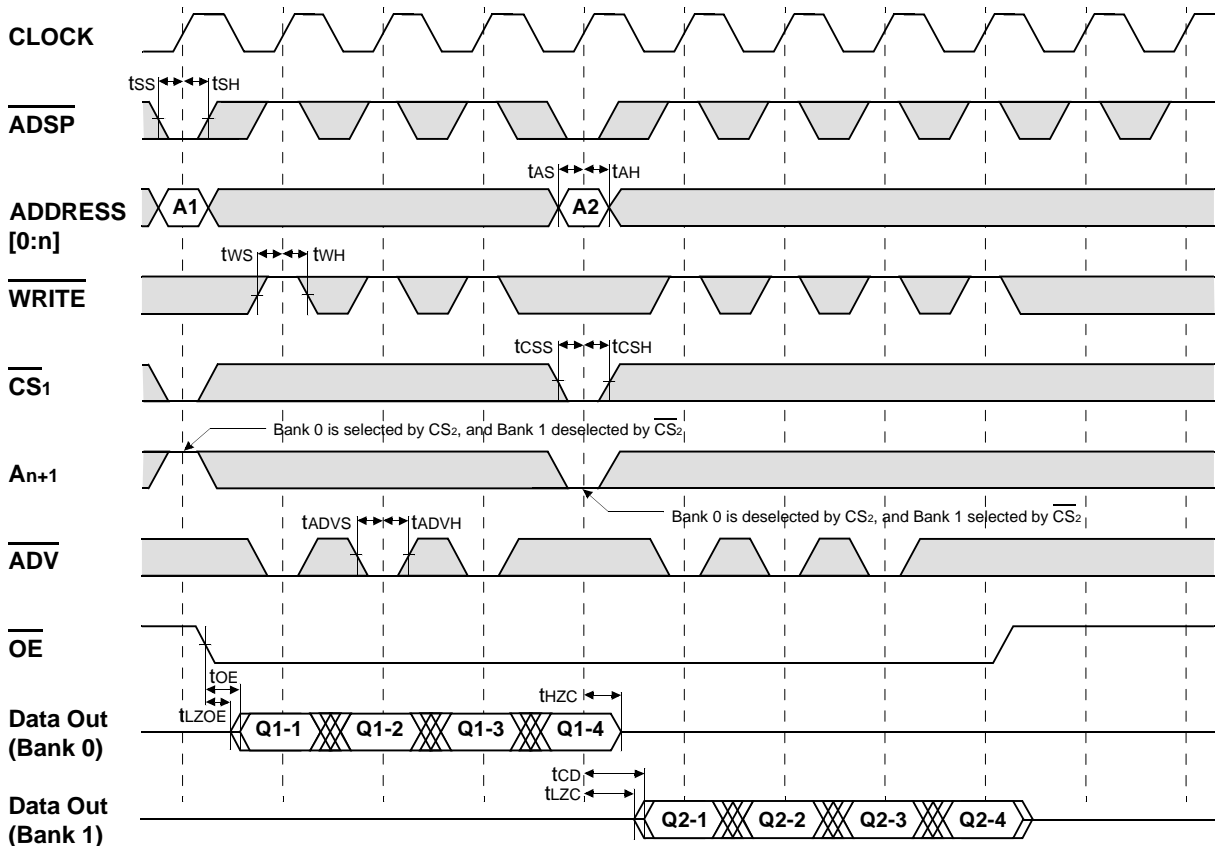

*NOTES n = 14 32K depth, 15 64K depth, 16 128K depth

□ Don't Care ⊗ Undefined

PACKAGE DIMENSIONS

100-TQFP-1420A

Units: millimeters/inches

