



10/100/1000BASE-T TCP OFFLOAD ENGINE, RDMA, ISCSI/ISER AND ETHERNET CONTROLLER

FEATURES

- **Single-chip solution for LAN on Motherboard (LOM) and Network Interface Card (NIC) applications**
 - Integrated 10BASE-T/100BASE-TX/1000BASE-T transceivers
 - Integrated SerDes (BCM5706S)
 - Host interfaces
 - PCI v2.3—32/64 bits, 33/66 MHz
 - PCI-X v1.0—64 bits, 66/100/133 MHz
- **TCP offload engine**
 - Full “fast Path” TCP offload
 - Designed for Microsoft’s TOE Chimney Architecture
- **iSCSI controller**
 - iSCSI initiator
 - iSER (iSCSI over RDMA)
- **RDMA controller (RNIC)**
 - RDMA over TCP (iWARP)—RDMAC 1.0 compliant
 - Hardware-based data placement in application buffers without CPU intervention (for User and Kernel modes)
- **Other performance features**
 - TCP, IP checksum
 - TCP segmentation
 - Adaptive interrupts
 - Message Signal Interrupt (MSI) support
- **Robust manageability**
 - PXE 2.0 remote boot
 - Alert Standard Format (ASF v1.0) support
 - Wake-On LAN
 - IPMI 'pass-through' mode
 - Statistic gathering (SNMP MIB II, Ethernet like MIB, Ethernet MIB (802.3x, clause 30))
 - Comprehensive diagnostic and configuration software suite
 - ACPI 1.1a compliant—power management
- **Advanced network features**
 - Virtual LANs—802.1q VLAN tagging
 - Jumbo frames (9 KB)
 - 802.3x flow control
- **Low-power CMOS design**
- **On-chip power circuit controller**
- **400-ball 21x21 mm FBGA package**
- **3.3V I/Os**
- **JTAG**

SUMMARY OF BENEFITS

- **Industry’s smallest 10/100/1000 TOE solution—power and space optimized for LOM and low-profile NIC applications.**
- **Extremely low CPU utilization for TCP/IP applications**
 - Host CPU is free to run application code
 - Easy integration with Microsoft’s TOE Chimney Architecture
- **Accelerated IP-based storage**
 - Lower CPU utilization for file-level storage protocols such as CIFS and NFS
 - iSCSI functionality with low CPU utilization
- **RDMA support for data placement in application buffers reduces CPU utilization and lowers data transit latencies. The result is improved application performance and faster user response time.**
- **Interoperable with:**
 - Broadcom’s Gigabit controller family – BCM570x
 - Existing Ethernet 10/100/1000 network infrastructure
- **Future-proof**
 - Flexible implementation for TCP, iWARP and iSCSI can accommodate specification changes and interoperability issues
- **Performance-focused – optimized for throughput and CPU utilization**
 - Adaptive interrupts
 - MSI allows interrupt distribution in a multi-CPU host system
 - Support for PCI-X—allows sufficient bandwidth for wire speed operation
- **Robust and highly manageable**
 - PXE 2.0, ACPI 1.1, Wake-On LAN, ASF 1.0
 - Integrated cable testing—link quality, length, pair skew, pair polarity, pair swap
 - IPMI 'pass-through' capability allows on-board management controllers access to the network in OS-present and OS-absent states
- **Server class reliability, availability and performance features**
 - Link aggregation and load balancing
 - Switch-dependent
 - 802.3ad (LACP), generic trunking (GEC/FEC)
 - Switch and NIC independent
 - PCI hot plug
- **Low power for zero airflow implementations**
 - Advanced power management
- **Minimal real estate—ideal for LOM**
 - On-chip power circuit controller

OVERVIEW

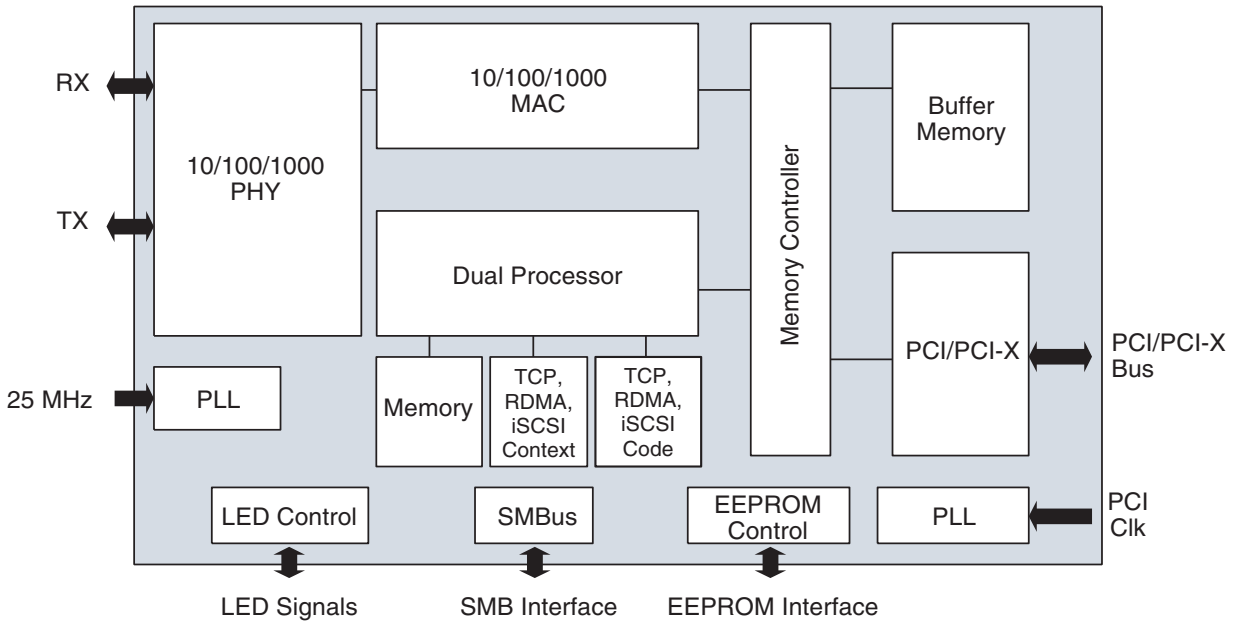

The **BCM5706** provides a fully integrated Layer 4 and Layer 5 solution - TCP/IP, RDMA and iSCSI 1.0/iSER along with a complete 10/100/1000BASE-T Gigabit Ethernet, IEEE 802.3 compliant Media Access Control (MAC) and Physical Layer Transceiver solution for high performance network applications. By itself the **BCM5706** provides a complete single-chip Gigabit Ethernet NIC with a TCP/IP Offload Engine, RDMA NIC (RNIC), iSCSI 1.0/iSER HBA or LOM solution.

The **BCM5706** is different from other network controllers because it can process the TCP/IP and relevant L5 protocols on data directly from the application buffers on the host, therefore relieving the host CPU from these time-consuming operations. On the receive path, the **BCM5706** processes the frame up to the highest layer supported present in it, e.g., the **BCM5706** processes the frame for RDMA when the frame is an RDMA frame.

With the appropriate configuration, the **BCM5706** can simultaneously support any two of the following three functions:

- RDMA Network Interface Controller (RNIC)
- iSCSI or iSER Host Bus Adapter
- TOE Chimney enabled network accelerator

Target Applications of the BCM5706

- Gigabit Ethernet NICs and LAN-on Motherboard (LOM)
- iSCSI 1.0 / iSER Host Bus Adapters (HBA)
- RDMA Network Interface Card (RNIC)

Network Interface Cards (NIC) designs		LAN on Motherboard (LOM) designs	
10/100/1000 BASE-T	PCI 2.3 Adapters PCI-X v1.0 Adapters	10/100/1000 BASE-T	PCI 2.3 LOM PCI-X v1.0 LOM
1000 BASE-SX	PCI 2.3 Adapters PCI-X v1.0 Adapters	1000 BASE-SX	PCI 2.3 LOM PCI-X v1.0 LOM
1000 BASE-LX	PCI 2.3 Adapters PCI-X v1.0 Adapters	1000 BASE-LX	PCI 2.3 LOM PCI-X v1.0 LOM

Broadcom[®], the pulse logo, and **Connecting everything**[®] are trademarks of Broadcom Corporation and/or its subsidiaries in the United States and certain other countries. All other trademarks mentioned are the property of their respective owners.

Connecting
everything[®]



BROADCOM CORPORATION
16215 Alton Parkway, P.O. Box 57013
Irvine, California 92619-7013

© 2004 by BROADCOM CORPORATION. All rights reserved.

5706-PB04-R 03/31/04

Phone: 949-450-8700
Fax: 949-450-8710
E-mail: info@broadcom.com
Web: www.broadcom.com