

## Dual sensing precision triac control thermostat

INTEGRATED ELECTRONIC SOLUTIONS  
1 BUTLER DRIVE  
HENDON SA 5014  
AUSTRALIA



# Dual sensing precision triac control thermostat

## OM1894

<b>CONTENTS</b>		
1	FEATURES	
2	GENERAL DESCRIPTION	
3	ORDERING INFORMATION	
4	PINNING INFORMATION	
4.1	Pinning layout	
4.2	Pin description	
5	BLOCK DIAGRAM	
6	FUNCTIONAL DESCRIPTION	
6.1	$V_{CC}$ – Common, positive DC supply	
6.2	$V_{EE}$ – Negative DC supply, substrate	
6.3	PWR – Power supply and synchronisation from the mains supply line	
6.4	ext_Reset – Reset status and control	
6.5	CI – triac drive control input	
6.6	MODE – external triac ON/OFF control sense, or internal logic	
6.7	TRG – Triac gate drive	
6.8	PX – triac gate pulse width external setting	
6.9	SA and SB – Sensor inputs	
6.10	CAP – Timing capacitor	
6.11	OP – output of thermostat latches	
7	LIMITING VALUES	
8	CHARACTERISTICS	
9	APPLICATION INFORMATION	
9.1	Design considerations	
9.2	Sensor function	
9.3	Triac drive control input, and mode	
9.4	Gate drive	
9.5	Pulse width extension	
9.6	Power supply requirements	
9.7	Startup reset	
9.8	Operating mode at switch on	
9.9	Zero-crossing detection	
9.10	Inductive loads	
9.11	Sensor circuits	
9.12	Common connection to load, triac, and sensor	
9.13	Important: Electrical safety warning	
10	APPLICATION CIRCUITS	
10.1	Dual sensor thermostat	
10.2	Dual sensor thermostat with different logic	
10.3	Fixed temperature cut-in thermostat	
10.4	Variable cut-in and cutout thermostat	
10.5	Freezer thermostat with over-temperature alarm	
10.6	Freezer thermostat with over-temperature alarm	
10.7	Food warming plate with two sensors and single heater	
11	PACKAGE OUTLINES	
12	SOLDERING	
12.1	Introduction	
12.2	DIP	
12.2.1	Soldering by dipping or by wave	
12.2.2	Repairing soldered joints	
12.3	SO	
12.3.1	Reflow soldering	
12.3.2	Wave soldering	
12.3.3	Repairing soldered joints	
13	DEFINITIONS	
14	IES INFORMATION	
15	DISCLAIMER <sup>(1)</sup>	

(1) The contents of this document are subject to the disclaimer on page 28

# Dual sensing precision triac control thermostat

OM1894

## 1 FEATURES

- rfi elimination triac drive circuit
- Low external component count
- Low supply current required
- Variable ON and OFF cycle times
- Sense circuit outputs available
- External ON/OFF triac control available
- No DC component in the AC mains supply
- The ON period always has an odd number of half cycles, and the OFF period an even number
- The sensors are AC powered, minimising DC supply and filtering needs
- Hysteresis can be set with user selected components.
- Independently variable (or fixed) cut-in and cut-out setting possible with dual sense input circuits
- Dual or single sensor operation possible
- Gate pulse width may be externally set
- Negative triac gate drive (avoids insensitive quadrant operation)

## 2 GENERAL DESCRIPTION

The OM1894 is a monolithic bipolar circuit for triggering a triac in applications where accurate control is required from one or two sensors such as NTC (Negative Temperature Coefficient) or PTC thermistors. It is suitable for a broad range of applications, extending from the zero-crossing control of a compressor cooling motor, a heating element, or to the control of fan motors and other complex loads.

It is designed to accept a wide variety of resistive and other sensors, using two independent balanced current comparator input circuits in which the signal current derived from the sensor(s) is compared with currents derived from a fixed or variable resistor network.

Because the operation of the OM1894 uses characteristics of triacs which are common to typical triacs, but may show some variation in triacs designed to emphasise specific uncommon features, it is preferable to use triacs which have been characterized and specified as suitable for use in this application.

The triac firing circuit uses a unique circuit arrangement by which load current zero crossing is detected, and a widened gate pulse applied during the critical current zero crossing period. Triac conduction is therefore maintained throughout the zero crossing time, ensuring that rfi transients are not generated during this time. With inductive loads only the final half cycle that ends an ON period (made up of an odd number of mains half cycles), will finish with a voltage transient. This may still need a snubber network to limit dv/dt, although it will not be required for the consecutive conducting half cycles during the ON time.

The OM1894 provides a triac controller which offers circuits using a minimum number of components, yet giving great flexibility and accuracy in triac controlled applications.

## 3 ORDERING INFORMATION

TYPE NUMBER	PACKAGE		
	NAME	DESCRIPTION	VERSION
OM1894P	DIP16	plastic dual in-line package; 16 leads (300 mil)	SOT38-1
OM1894T	SO16	plastic small outline package; 16 leads; body width 3.9 mm	SOT109-1

# Dual sensing precision triac control thermostat

OM1894

## 4 PINNING INFORMATION

### 4.1 Pinning layout

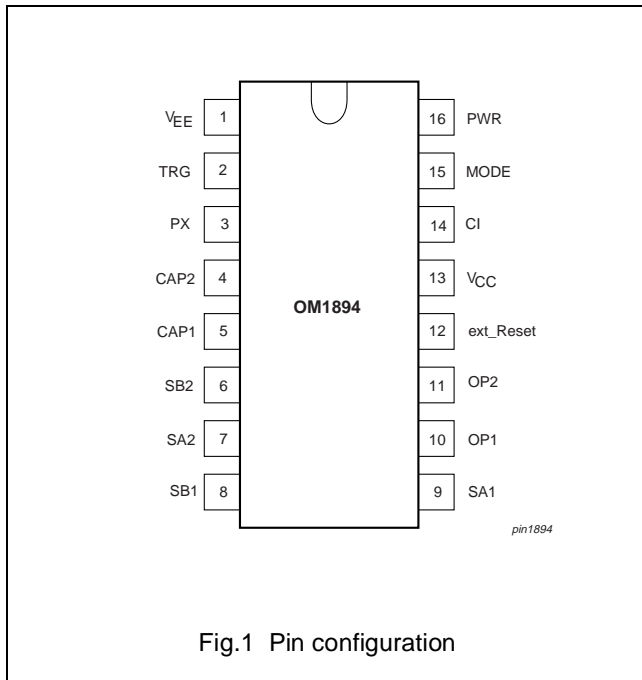

Fig.1 Pin configuration

### 4.2 Pin description

SYMBOL	PIN	DESCRIPTION
$V_{EE}$	1	Negative supply
TRG	2	Triac gate drive
PX	3	Gate pulse extender
CAP2	4	Sense capacitor 2
CAP1	5	Sense capacitor 1
SB2	6	Sense Input B2
SA2	7	Sense Input A2
SB1	8	Sense Input B1
SA1	9	Sense Input A1
OP1	10	Sense output 1
OP2	11	Sense output 2
ext_Reset	12	Reset input/output
$V_{CC}$	13	Positive Common
CI	14	Control input, triac ON/OFF
MODE	15	Invert control sense & function
PWR	16	AC line sense and power input

## 5 BLOCK DIAGRAM

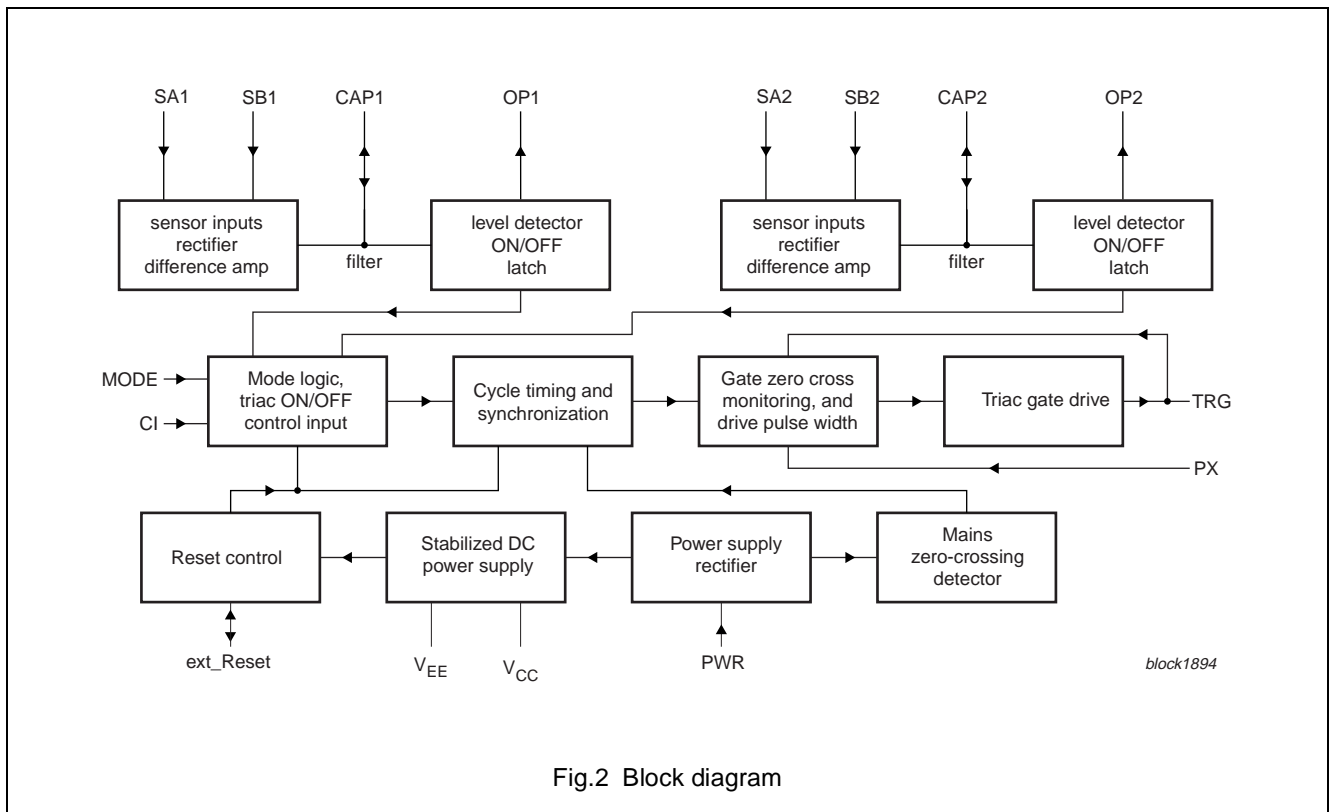

Fig.2 Block diagram

# Dual sensing precision triac control thermostat

OM1894

## 6 FUNCTIONAL DESCRIPTION

### 6.1 $V_{CC}$ – Common, positive DC supply

The positive DC supply rail for the control IC type OM1894 is used as the common reference. This is always connected to the T1 terminal of the triac, and being the positive supply rail allows negative gate drive to the triac in both positive and negative supply half cycles on T2. By driving the triac in this way the insensitive quadrant (negative T2 voltage, and positive gate triggering signal) of triacs is avoided.

### 6.2 $V_{EE}$ – Negative DC supply, substrate

This pin connects to the substrate and the internally generated and regulated negative DC supply, and should be bypassed to  $V_{CC}$  (common) by a capacitor of typically 100  $\mu$ F. The capacitor needs to be sufficiently large to maintain the operating voltage during the half cycle when it is not being charged, as well as to provide the energy to drive the triac gate during the gate pulse.

Internal supply sensing prevents the commencement of an ON cycle while the voltage is too low for reliable circuit operation. If during an ON cycle the supply voltage falls below this level the ON cycle will terminate at the first opportunity consistent with the logic cycle algorithm.

### 6.3 PWR – Power supply and synchronisation from the mains supply line

The PWR input provides both a synchronisation signal for the logic functions of the OM1894, as well as the DC current used to provide the power supply from which the OM1894 is powered. Signals are derived which indicate the phase and magnitude of the signal on the AC supply. Three states, positive, zero and negative, of this signal is recognised for synchronisation of the triggering times to the mains.

See Figure 3, OM1894 Power Supply Circuit.

The PWR pin is driven by a current limiting resistor from the mains supply. During the positive half cycle

current flows through the upper diode D1 to the positive common rail, while on a negative half cycle the current flows through the lower diode D2, and charges the  $V_{EE}$  power supply capacitor.

The zero crossing is signalled by the two comparators, the output signals of which indicate whether the mains voltage is above the common rail voltage, or below the negative  $V_{EE}$ . There may be additional resistors in a simple network from the AC supply and  $V_{EE}$  to adjust these zero-crossing signals to provide a symmetrical response in the positive as well as the negative going direction.

As the AC signal passes through zero, comparators provide control signals  $T_p$  (when  $V_{PWR} > V_{CC}$ ) and  $T_n$  (when  $V_{PWR} < V_{EE}$ ) indicating whether the voltage on PWR pin is greater or less than  $V_{CC}$  or  $V_{EE}$  respectively. A resistor network ensures that these switching points correspond to equal positive or negative thresholds about the AC zero thus giving symmetrical zero-crossing information to the synchronisation and logic circuit.

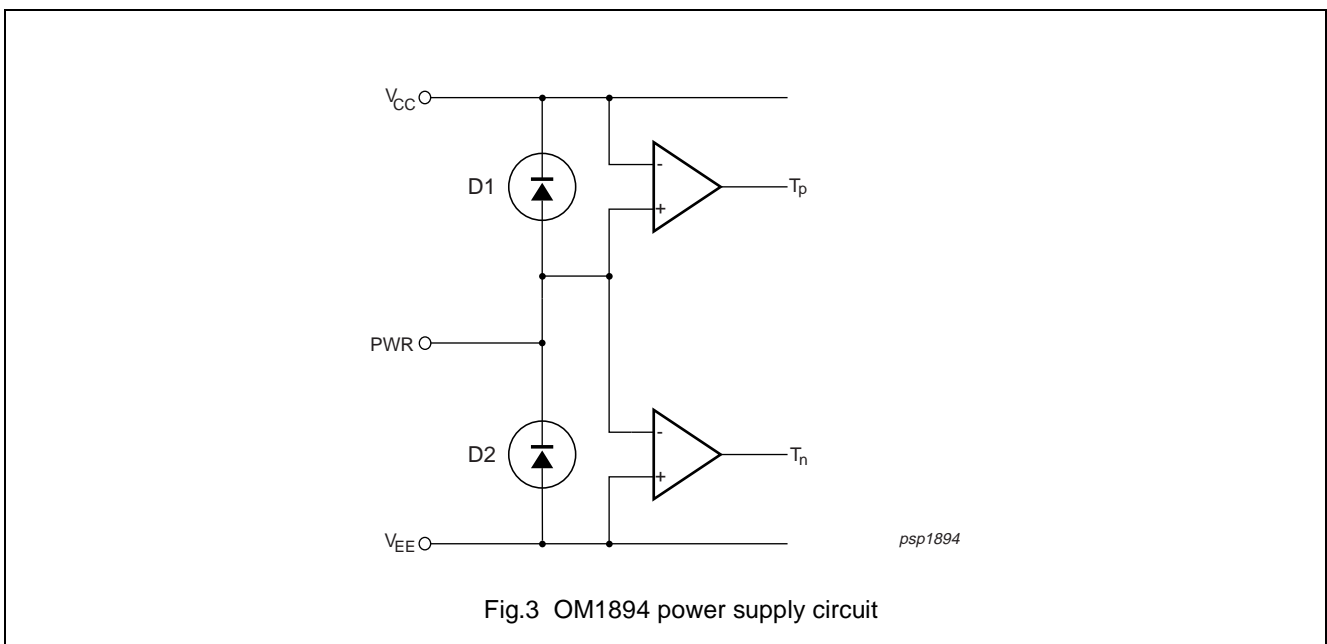

## Dual sensing precision triac control thermostat

OM1894

Synchronisation is obtained from the threshold comparators at the levels of  $V_{CC}$  and  $V_{EE}$  on the chip. Adjustment of the initial switching point, and hence the time of initiation of the first firing pulse, and its symmetry about the zero crossing point, is possible by varying the values of the resistors connected between PWR and the active supply, a resistor to  $V_{EE}$ , and a resistor to  $V_{CC}$ .

When the triac has switched on, the zero-crossing synchronisation information is derived from the voltage on the triac gate while it is conducting, although the polarity information provided by the PWR input signal continues to provide phase information to enable the ON and OFF transitions at the start and finish of an ON burst of conducting half cycles, to be synchronised to prevent repeated firing in the same polarity half cycle, and a resultant net DC load current.

### 6.4 ext\_Reset – Reset status and control

As the power supply rises towards its operating voltage, a reset signal is generated which holds the logic in an initial state until the voltage has risen to a sufficient value to sustain full operation.

The reset signal is active high to preserve a predictable voltage relationship with the Common supply rail ( $V_{CC}$ ) rather than  $V_{EE}$ . The ext\_Reset pin is pulled high by  $50\mu\text{A}$  when the internal reset signal is active. When the power supply voltage reaches the threshold, the ext\_Reset pin is pulled low ( $6\mu\text{A}$ ), and the controller then begins normal operation.

This ext\_Reset signal can be used to reset counters and other electronic logic circuits which need to begin operation in a known state.

Furthermore, when OM1894s are used in parallel, or with other control circuits, and external reset signal can be applied which will override these internally generated signals.

### 6.5 CI – triac drive control input

If MODE is connected to  $V_{CC}$  or  $V_{EE}$ , the Control Input (CI) is the input signal which allows external ON/OFF control of the triac with the exception of when the MODE pin is floating.

The voltage signal on CI will switch the triac ON or OFF in a manner which is synchronised to the mains zero crossings. This signal may change at any time, but the triac will only be switched ON or permitted to turn OFF, at a time that is consistent with controlling it at the earliest available opportunity consistent with the cycling algorithm which triggers the triac for an odd number of half cycles in each ON period, and lets it remain OFF for an even number of half cycles. In this way there is no DC current present in the mains supply when it is averaged over a large number of ON cycles, and at the same time for inductive loads, a new ON period begins on a half wave of the opposite polarity to the start and finish half wave of the previous run cycle.

The MODE pin provides the facility to invert the sense of the signal applied to the CI pin, so that a signal of the most appropriate polarity can be used without the need for an external gate to invert the signal.

### 6.6 MODE – external triac ON/OFF control sense, or internal logic

The mode pin is intended to be permanently wired for each application, and has three active states.

When MODE is connected to  $V_{CC}$  and held high, then CI is high for the triac to be ON, and low for OFF.

If MODE is connected to  $V_{EE}$ , then the ON/OFF sense is inverted, and for CI high the triac is OFF, and low for ON.

There is a special function available when the MODE pin is not connected which performs a function from the combined outputs of the two sensing stages. The signals from OP1 and OP2 are combined so that the triac is not permitted to run until both of the inputs are agreed that heat is needed.

In a similar manner the triac run cycle is not terminated until both inputs have changed state, and both OP1 and OP2 have reached the condition in which the run cycle can be terminated.

This is particularly applicable to the application of controlling a refrigerator with two sensors, with one sensor in the food compartment, and another mounted on the condenser. A cooling cycle is only permitted to begin if the food has reached its upper limit, at which cooling is needed. However this alone is not sufficient. The condenser should also have warmed to a temperature where any ice from condensed water vapour has been able to melt, and defrost the condenser. When both of these conditions have been satisfied, then a cooling cycle is permitted to start.

Similarly, when the food has cooled to the lower cut out temperature for the cabinet, the evaporator sensor must also have reached its cold operating temperature for the cooling cycle to end.

### 6.7 TRG – Triac gate drive

The triac gate output drives the gate through an external current setting resistor. It has in-built protection to withstand transient voltage signals which may be induced on the gate of

## Dual sensing precision triac control thermostat

OM1894

the triac by mains transients during firing. The gate drive current should be set to a value suited to the gate sensitivity of the triac used. The firing pulse width will need to be of such a width that the specified latching current of the triac when used with the design load has been reached before the gate pulse ends.

In the OM1894 the gate drive is first applied at the start of an ON period at the zero crossing of the mains supply. The leading edge of this obtained from the signal derived from the PWR resistor network before the falling mains voltage reaches zero. The gate pulse is applied for a time determined by either an internal time delay circuit, or if it is required to be for an extended time, by the addition of an RC network to the gate pulse extension pin PX.

On this first half cycle current is flowing in the triac, and subsequent zero crossings of the triac can be determined in another way. While a resistive load may have the zero crossing determined from the mains supply, this is not possible when the load is inductive (for example, when it is a motor). The current is no longer in phase with the supply voltage, and can reach zero at a time significantly lagging the supply voltage phase.

In the OM1894, the voltage of the triac gate has been found to provide an indicator of imminent zero crossing, and with an appropriate threshold circuit, the gate drive can be re-applied before the triac turns fully off. Again the gate pulse is determined by the length of the internal delay circuit, plus any additional delay from the application of external resistor and capacitors applied in parallel from the pin PX to  $V_{EE}$

### 6.8 PX – triac gate pulse width external setting

The gate pulse must be wide enough to be applied from the time the triac is

about to turn off until the increasing current in the triac in the opposite direction has reached the latching current of the triac being used.

While there is a time delay circuit within the OM1894 to provide a minimum gate pulse width, for lower powered loads, where it takes longer for the load current to reach the triac latching current, then it may be necessary to extend that gate pulse.

A parallel resistor and capacitor are connected from pin PX (pulse extender) to  $V_{EE}$  giving a pulse extension time of:

$$t_{pw} \approx 1.4 \cdot R \cdot C \quad (\text{s})$$

Thus for a capacitor value of 470pF, and a resistor of 1 M $\Omega$ , the pulse width would be typically 658 $\mu$ s.

### 6.9 SA and SB – Sensor inputs

The OM1894 has two separate and independent sensor circuits. This enables a single sensor to be used with the voltages dropped across the sensing elements and the setting circuit to be able to be independently applied to each sensing circuit.

Or there may be two sensors, permitting the temperature to be measured in different places, and the outputs of the sensor circuits to be logically combined from their independent outputs to give more useful functions.

While each sensor input circuit has a single input threshold, a feedback signal can be derived from the triac to change these thresholds to another value depending on whether the triac is ON or OFF.

Both of the sensor circuits within the OM1894 are identical.

The sensor inputs are symmetrical current inputs designed to accept AC signals referenced to common. See

figure 4, Sensor current comparator circuit.

By not using the DC supply rail to drive the sensing inputs, problems associated with providing sufficient DC current to drive the sensor and associated networks over the full operating range are avoided. In addition by providing balanced differential inputs operating at close to the  $V_{CC}$  rail potential, control signals which either increase or decrease with the parameter to be regulated (temperature, pressure, humidity etc.) can be handled.

A sensitive sensor can be used together with a level setting variable resistor in a bridge arrangement. A resistor can apply a current proportional to the voltage across the AC sensor to one of the two sensing inputs, and another equal resistor will give a current derived from the voltage on the setting resistor to the other. The circuit will be balanced when the two input currents are equal, and any change in the sensor resistance will generate a difference signal between the input currents to SA and SB. This difference is integrated in a capacitor connected to pin CAP.

When the current into pin SA is greater than the current into pin SB, the voltage on pin CAP will be driven negative towards the OFF threshold comparator. When the current difference is reversed, and the current into SB is the greater, then the current difference will charge CAP positively towards the upper ON threshold.

A typical circuit will power the sensing circuits via high value resistors taken from the AC supply. While the circuit is in balance the timing capacitor voltage remains steady, but once the sensed parameter changes and causes an imbalance, and the capacitor will charge or discharge depending on which input current is the greater.

# Dual sensing precision triac control thermostat

OM1894

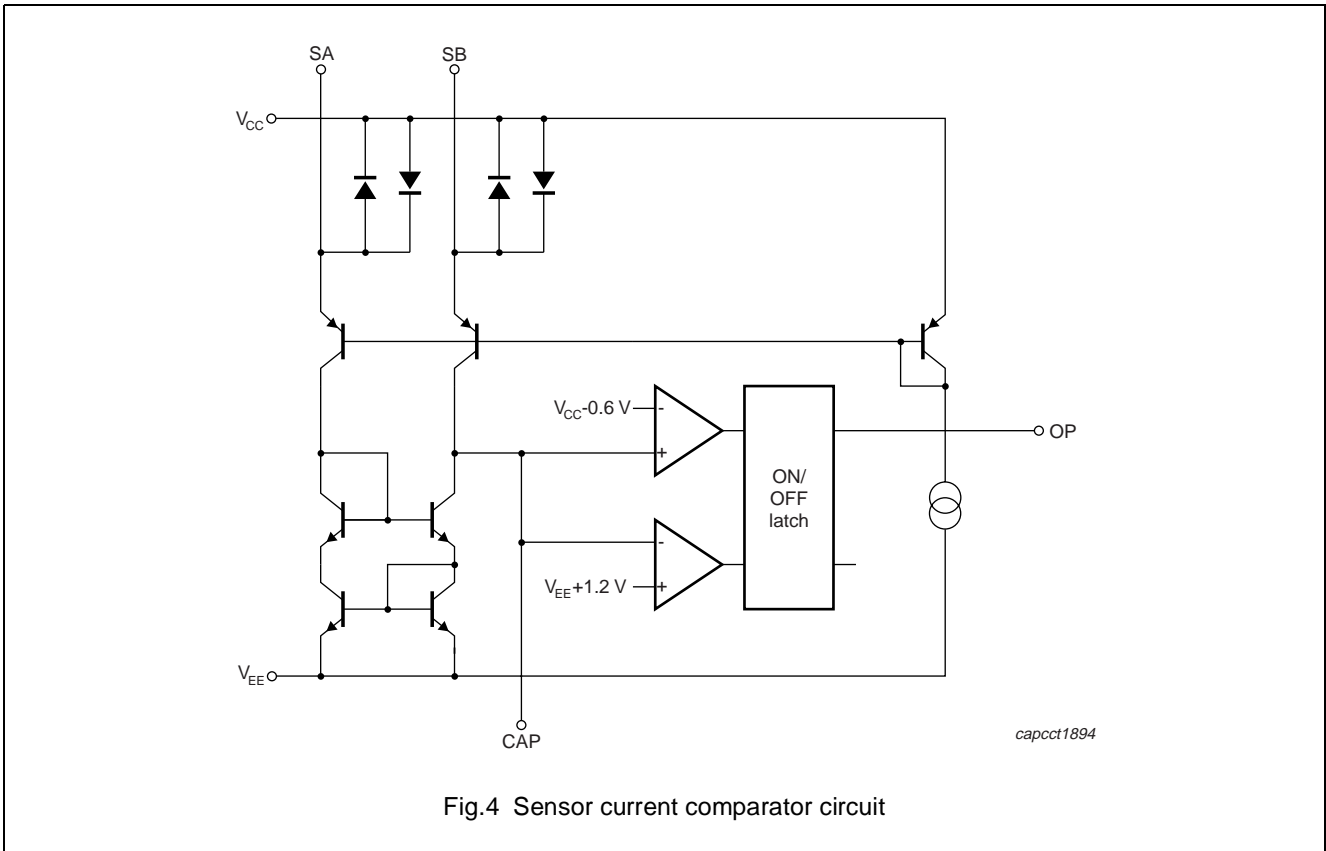

Fig.4 Sensor current comparator circuit

As a result of the imbalance, and after the delay needed for the voltage on CAP to reach the threshold voltage it will switch from ON to OFF or vice-versa. The charging or discharging current is the difference between the two current input signals applied to SA and SB.

An imbalance (apart from that resulting from the action of the sensor) between the currents applied to SA and SB can be created by an additional resistive path that introduces an AC signal from the AC signal across the triac when it is off to add to the signal already present in SA or SB. This imbalance can be used to increase the hysteresis around the control point, or to decrease it and to force more frequent cycling between the ON and OFF cycles. In the application circuit where the sensor is powered from

across the triac (OFF period) or from across the load (ON) then suitable selection of fixed resistor values give this electronically induced imbalance.

The timing capacitor connected to the CAP terminal provides inherent filtering of the sensing signal, and as the SA and SB inputs are driven by AC signals, filtering of transient interference signals is inherent in this circuit. However they may also be driven from a positive DC source—possibly from a remote sensor with its own power supply, and still have the advantage of the inherent interference rejecting characteristics of the timing capacitor.

Only the positive half of the input cycle is used to generate the difference between SA and SB: on the negative half cycle the voltage is clamped to one  $V_{BE}$  below the  $V_{CC}$  rail.

### 6.10 CAP – Timing capacitor

The timing capacitor is connected from CAP to either  $V_{EE}$  (substrate, -ve) or  $V_{CC}$  (common, +ve). The charging and discharge times of this capacitor set the ON and OFF cycle times.

The charging and discharging periods, that is the ON or OFF times, vary with the magnitude of the difference in input currents applied to SA and SB from the sensor bridge circuit. When the capacitor charges towards the  $V_{CC}$  rail, and reaches an upper threshold of one  $V_{BE}$  below the  $V_{CC}$  rail, then the request for firing latch is set in the ON condition; the control circuit is ready to start an ON cycle at the next appropriate zero-crossing of the mains supply. See figure 4, Sensor Current Comparator Circuit.



## Dual sensing precision triac control thermostat

OM1894

The first half cycle for which the triac is conducting at the start of an ON period is synchronised with the mains zero crossing signal. Subsequent triac triggering during the conduction period is derived from the signals obtained from the triac gate. In this way resistive or inductive loads are controlled by the same circuit. The OM1894 uses an odd number of half cycles during the ON period, with an even number in the following OFF period. This ensures that every ON period starts by conducting in the opposite direction to the first half cycle of the previous ON period. Important for an inductive load where premagnetization and inrush currents need to be considered.

During the ON cycle, the imbalance in the input signal currents that caused the capacitor to charge to the upper threshold voltage, will change, and the new difference between the signals into SA and SB discharges the capacitor, with the voltage on the CAP pin approaching the  $V_{EE}$  rail. The lower threshold is two  $V_{BE}$  above  $V_{EE}$ , and when this threshold is

reached the latch which was set by the request for an ON cycle is reset. When the ON latch is reset, the timing circuit stops driving the gate only after the programmed odd or even number of conducting half cycles.

### 6.11 OP – output of thermostat latches

The ON/OFF latch output from each to the two sensing circuits are brought to external pins so that possible logic and timing functions can be achieved in external circuits before a final ON/OFF signal is applied to control the triac.

These outputs in the OFF, or low state are held low by a constant current source to  $V_{EE}$  of  $6\mu\text{A}$ . In the ON state they are pulled high to Common with an open collector transistor with greater than  $50\mu\text{A}$  pull-up capability.

In the simplest configuration one or both of the OP pins (OP1 & OP2) may be connected together and used to drive the Control Input pin (CI).

The control input has a high impedance input with a voltage threshold 3  $V_{BE}$  below the common rail. If either OP1 or OP2 are high, then the input to CI will be high.

Considerable flexibility is available as to how this facility will be used, and the approach will differ for heating and cooling applications, as well as for the logical consequence of either or both OP1 and OP2 being able to pull CI high.

As the SA and SB inputs are similar, one pulling CAP low, and the other high, then the signal on the corresponding OP pin is inverted by exchanging the SA and SB inputs.

Likewise the MODE pin inverts the sense of the CI pin, so that when CI is pulled high the triac can be either ON or OFF as determined by the MODE pin connection.

When MODE is left open circuit, none of OP1, OP2 or CI are used, and these should be also left open circuit. The internal logic that is applied in this case is discussed above.

## 7 LIMITING VALUES

In accordance with the Absolute Maximum Rating System (IEC 134).

All voltage measured with respect to  $V_{CC}$ , Common.

SYMBOL	PARAMETER	CONDITIONS	MIN.	MAX.	UNIT
I	DC current (any pin except 1 & 2)		–	20	mA
I	DC current (pins 1 & 2)		–	70	mA
$V_{CAP}$	Voltage range CAP1, CAP2, pins 5 & 4	$V_{5-13}, V_{4-13}$	$V_1-0.8$	+0.8	V
$V_{SA}$	Voltage range SA1, SA2, pins 7 & 9	$V_{7-13}, V_{9-13}$	-0.8	+0.8	V
$V_{SB}$	Voltage range SB1, SB2, pins 6 & 8	$V_{6-13}, V_{8-13}$	-0.8	+0.8	V
$V_{TRG}$	Voltage range TRG, pin, transient	$V_{2-13}$	$V_1-30$	+50	V
$V_{PWR}$	Voltage range PWR, pin 16	$V_{16-13}$	$V_1-0.8$	+0.8	V
$V_{PX}, V_{OP}, V_{ext\_reset}, V_{CI}, V_{MODE}$	Voltage range PX, OP1, OP2, ext_Reset, CI, MODE, pins 3, 10, 11, 12, 14, & 15	$V_{10-13}, V_{11-13}, V_{12-13}, V_{3-13}, V_{14-13}, V_{15-13}$	$V_1-0.8$	+0.8	V
$P_{tot}$	total power dissipation		–	300	mW
$T_{stg}$	storage temperature		-40	+150	°C
$T_{amb}$	operating ambient temperature		0	+125	°C

# Dual sensing precision triac control thermostat

OM1894

## 8 CHARACTERISTICS

At  $T_{amb} = 25^{\circ}\text{C}$ ; Voltages are specified with respect to  $V_{CC}$ .

SYMBOL	PARAMETER	CONDITIONS	MIN	TYP	MAX	UNIT
<b>Power supply</b>						
$-V_{EE}$	supply voltage (operating)	$I_{CC} = 1 \text{ mA}$	7.4	8.0	8.6	V
$-I_{EE}$	quiescent current	with pins SA, SB and TRG open circuit	–	230	300	$\mu\text{A}$
<b>Power and sensing input, pin PWR</b>						
$V_{ut}$	upper threshold		–	0	–	V
$V_{lt}$	lower threshold		–	$V_{EE}$	–	V
<b>Reset output/input, pin ext_Reset</b>						
$V_{reset}$	internal power reset		–	0	–	V
$I_{high}$	reset active pull-up current	$V_{ext\_Reset} = -2 \text{ V}$	–	50	–	$\mu\text{A}$
$I_{low}$	reset off pull-down current	$V_{ext\_Reset} = V_{EE}$	–	6	–	$\mu\text{A}$
$V_{reset}$	external reset threshold		–	-2	–	V
<b>Gate drive, pin TRG</b>						
$I_G$	gate current (triac T1 to $V_{CC}$ )	set by $R_G$ connected from TRG to gate	–	–	50	mA
$V_{Gth-}, V_{Gth+}$	gate sensing thresholds (triac G to $V_{CC}$ , positive and negative)	gate voltage sensing of current zero crossing	-80 +80	-100 +100	-120 +120	mV mV
<b>Pulse stretching, pin PX</b>						
$t_{pulse}$	gate pulse width	PX not connected	–	100	–	$\mu\text{s}$
$t_{pulse}$	stretched gate pulse width	$1\text{M}\Omega$ & $470\text{pF}$ in parallel from PX to $V_{EE}$	–	658	–	$\mu\text{s}$
<b>Measuring inputs, pins SA1, SB1, and SA2, SB2</b>						
$V_S$	voltage	$I_{SA} = I_{SB} = +50 \mu\text{A}$	–	0	–	V
$V_{OS}$	offset voltage, $V_{SA} - V_{SB}$	$I_{SA} = I_{SB} = +100 \mu\text{A}$	-5	–	+5	mV
$I_{S(peak)}$	peak sense input current	$I_S = I_{SA} + I_{SB}$	–	–	500	$\mu\text{A}$
$I_{CAPoffset}$	offset current (as a % of $I_{SA}$ or $I_{SB}$ , where $I_{CAPoffset} = (I_{CAP}/I_{SA}) \times 100\%$ , measured at $I_{SA} = I_{SB} = +100 \mu\text{A}$ dc)		-2.2	0	+2.2	%
<b>Timing capacitor, pins CAP1, and CAP2</b>						
$I_{CAP/(I_{SA}-I_{SB})}$	charge current ratio	$I_{SA} = I_{SB} = +100 \mu\text{A}$	–	0.9	–	
$V_{CAP/(UT)}$	cap voltage upper trip (ON) threshold	Driven towards this threshold when $I_{SA} < I_{SB}$	–	-0.6	–	V
$V_{CAP/(LT)}$	cap voltage lower trip threshold	Driven towards this threshold when $I_{SA} > I_{SB}$	–	$V_{EE}-1.2$	–	V
<b>Sensing circuit outputs, pins OP1, and OP2</b>						
$I_{op(Low)}$	sense circuit output LOW, pull-down current	$V_{OP} = V_{EE}$	–	6	–	$\mu\text{A}$
$V_{CAP/(LT)}$	sense circuit output HIGH, pull-up current	$V_{OP} = -2 \text{ V}$	–	50	–	$\mu\text{A}$

# Dual sensing precision triac control thermostat

OM1894

SYMBOL	PARAMETER	CONDITIONS	MIN	TYP	MAX	UNIT
<b>Triac drive control input, pin CI</b>						
$V_{\text{threshold}}$	control input threshold		–	–2	–	V
$I_{\text{in}}$	input current	$V_{\text{CI}} = V_{\text{CC}}$	–	–	1	$\mu\text{A}$
<b>Triac drive mode, pin MODE</b>						
$V_{\text{ut}}$	upper mode threshold		–	–0.6	–	V
$V_{\text{lt}}$	lower mode threshold		–	$V_{\text{EE}}+1.2$	–	V
$I_{\text{in}}$	mode control input current	$V_{\text{mode}} = V_{\text{CC}}$ or $V_{\text{EE}}$	–	–	10	$\mu\text{A}$

## 9 APPLICATION INFORMATION

### 9.1 Design considerations

Resistors connected directly to the AC supply rail should be specified to withstand the voltage. It is recommended that (Philips BC Components) VR37 (or VR25) high-ohmic / high-voltage resistors be used. These resistors meet the safety requirements of a number of international standards on high voltage applications.

### 9.2 Sensor function

For the two sensor sections of the OM1894, the function is as follows.

When the current in SA is greater than the current in SB, then CAP is pulled low toward its lower (OFF) threshold.

When it reaches this threshold and trips the latch, then the output pin pulls OP low towards  $V_{\text{EE}}$ .

When SB is greater than SA, and the voltage on CAP reaches the upper threshold, then the output is switched HIGH pulling OP high towards  $V_{\text{CC}}$  with a significantly larger current than when pulled low.

If OP1 and OP2 are connected together, then if either OP1 or OP2 is pulled into the HIGH state, then the combined output is pulled HIGH. To give a low output both OP1 AND OP2 must be LOW.

OP1 and OP2 will directly drive standard 4000 series CMOS logic gates (for example Philips HEF4xxx). Pull-down resistors are not needed. They may also be used to drive inputs on a microcontroller.

### 9.3 Triac drive control input, and mode

The control input (CI) is a high impedance voltage sensing input and may be driven by either one (or both connected together) of the OP1 and OP2 sensing circuit outputs.

It can also be driven by a standard CMOS gate output, or microcontroller output. If used with a microcontroller the input threshold voltage has been chosen to be suitable for use with a micro running off its own power supply with  $V_{\text{CC}}$  connected to  $V_{\text{DD}}$  on the micro.

This input is active HIGH if the MODE pin is connected to  $V_{\text{CC}}$ . If MODE is connected to  $V_{\text{EE}}$ , the input sense of CI is inverted, and it is active LOW: that is gate pulse are applied to turn the triac ON, when the signal on CI is LOW.

When MODE is not connected, then internal logic takes the signals of OP1 and OP2 and combines them so that starting from an initial OFF state, the triac will only be turned ON when both of the input sensing circuits have their ON latch set (that is when both OP1 and OP2 are high).

The run cycle is latched, and even when OP1 and OP2 might go LOW individually, the run cycle is not stopped until both OP1 and OP2 are low, and both input sensor circuit latches have been set to the OFF state.

### 9.4 Gate drive

The 300  $\Omega$  gate resistor shown in the application circuits gives a little over 10 mA gate drive. Thus for the circuit shown a triac would need to be specified that is suitable for 10 mA triggering with negative triggering signal for both positive and negative voltage on T2. From the threshold levels determined from the resistive network on PWR, and the AC supply, the timing of the first gate pulse in a conduction cycle can be calculated (assuming a sine wave supply). The specification of the triac will indicate the latching current for switch-on, and knowing the minimum load with which the circuit is to operate, then proper design will ensure that the gate pulse will be long enough, and will not be removed before the triac current reaches this figure.

### 9.5 Pulse width extension

When the gate pulse is extended by adding a parallel resistor and capacitor from the pulse width extension pin PX to  $V_{\text{EE}}$ , the power supply current used in driving the gate is a major portion of the available DC

## Dual sensing precision triac control thermostat

OM1894

power supply needed in the circuit. This has therefore to be included in the calculation of the total power supply requirements.

In particular allowance must be made for the changes in triac characteristics below normal room temperature.

The choice of resistor value is a compromise between the current flow in that resistor (further power supply requirements if the resistor is low in value), and the loss of accuracy for high value resistors with the OM1894 input current, and leakage current possibilities on the board surface for values over 1 M $\Omega$ .

### 9.6 Power supply requirements

The DC power supply current available for the operation of the circuit is derived from the resistor connected to the PWR terminal. On the negative half cycle of the AC signal applied to this resistor, the current into the OM1894 charges the power supply capacitor (typically 100  $\mu$ F) connected between  $V_{CC}$  and  $V_{EE}$ .

Apart from the current required by the chip, the triac gate drive presents the major DC current requirement of the circuit. As the gate pulse must be wide enough for the load current to reach the triac's specified holding current, this may be a significant load on the DC supply (especially with small resistive and inductive triac loads).

### 9.7 Startup reset

While the reset pin provides an output of the reset condition within the OM1894, and provides a suitable reset signal to reset timers, and external logic circuits which might be used it can also be driven from an external reset source, or connected to another OM1894 reset pin.

It is active HIGH with 50  $\mu$ A pull up current, and once the power supply

voltage is above the reset voltage threshold, falls to a 6  $\mu$ A pull down condition.

An externally applied reset signal will override these currents, and reset the internal circuitry of the OM1894 in accordance with the state of the externally applied signal.

When two or more OM1894 have reset interconnected, the reset will only be freed when the first of the OM1894 devices reaches the shunt level. The hysteresis on reset pin is to ensure that full operating voltage is reached before reset to internal logic is release during start up.

### 9.8 Operating mode at switch on

The return connection of the capacitors connected to the CAP terminals may determine whether the OM1894 is in an ON or an OFF cycle once the power supply reaches the voltage at which the reset signal is released following application of the the supply voltage. However, it is more likely that the supply voltage will rise more slowly than the input current differences will charge the capacitor on the CAP terminal, and therefore the voltages on CAP1 and CAP2 will have already charged or discharged to their operating level; and these voltages will have already reached a level sufficient to change the state of the ON/OFF latch.

The application circuits show the capacitor connected to  $V_{EE}$ , which ensures that it will initially be in the OFF mode.

### 9.9 Zero-crossing detection

The two thresholds at which the zero-crossing of the input voltage on PWR is sensed are the two supply rails,  $V_{CC}$  and  $V_{EE}$ . This means that a simple network of resistors is usually required to ensure switching at the same threshold above the  $V_{CC}$

common positive rail as below it. In the application circuits, in addition to the resistor from the mains active to PWR, an additional equal resistor is connected between PWR and  $V_{EE}$  to make the positive and negative thresholds the same. The positive threshold will therefore be an equal voltage above  $V_{CC}$  due to the divider action of the resistors, while the negative threshold is still equal to  $V_{EE}$ , at which point no current is flowing in the second resistor.

If a third resistor is added from PWR to  $V_{CC}$ , suitable values can be calculated to give equal positive and negative thresholds larger than the DC supply voltage of  $V_{CC} - V_{EE}$ . For example, if  $V_{CC} - V_{EE} = 7$  V, and the resistor to the supply is 220 k $\Omega$  from PWR, then if the resistor from PWR to  $V_{EE}$  is the same (220 k $\Omega$ ), the upper threshold is +7 volts, and the lower one -7 volts. However if the resistor between PWR and  $V_{EE}$  is only 110 k $\Omega$ , and a further resistor of 220 k $\Omega$  is connected between PWR and  $V_{CC}$ , then the thresholds are  $\pm 14$  volts.

Note that the current flowing in the second resistor causes a negligible loss to the DC supply, as the voltage across it is limited to approximately  $V_{CC} - V_{EE}$ .

### 9.10 Inductive loads

Because of the triac control method used in the OM1894, both resistive and inductive loads can be controlled without changing the controller circuit.

In the application circuits shown in this data sheet, snubber networks are not shown connected across the triac, nor is an rfi filtering capacitor shown between active and neutral.

The OM1894 provides zero crossing firing of both inductive and resistive loads, and rfi suppression may only be needed to filter residual transient behaviour of the triac which would be

## Dual sensing precision triac control thermostat

OM1894

present even if the gate was DC fired. For example with high current resistive loads.

However with inductive loads, while the OM1894 provides zero crossing firing during the run cycle at every current zero crossing through this period, when the last half cycle finishes at zero current (not in phase with the mains voltage supply) a single voltage transient will occur which may exceed the  $dv/dt$  rating of the triac, and need a snubbing circuit to bring it within the triac ratings. Also that last transient may generate rfi which exceeds the limits published in the standards. However it will no longer be at 100Hz and higher harmonics, as is the case with interference generated in phase with the supply frequency; it will only be a single transient coming at the end of the ON cycle, and therefore occurring a lot less frequently, and falling under other clauses of the standard.

### 9.13 Important: Electrical safety warning

OM1894 circuit is connected to the mains electrical supply and operates at voltages which need to be protected by proper enclosure and protective covering. Application circuits for OM1894 should be designed to conform to relevant standards (such as IEC 65, or Australian Standards AS3100, AS3250 and AS3300), it should only be used in a manner that ensures the appliance in which they are used complies with all relevant national safety and other Standards.

It is recommended that a printed circuit board using this integrated circuit be mounted with non-conductive clips, and positioned such that the minimum creepage distances from the assembly to accessible metal parts, and between high voltage points cannot be transgressed.

### 9.11 Sensor circuits

In all of the circuits shown the sensor is common to the  $V_{CC}$  and triac TI terminals. Other circuits may use the sensor in series with one of the input pins SA and SB. In the same way, because the input circuit is symmetrical, sensors which generate signals varying in the opposite direction (for example positive temperature coefficient resistors vis a vis negative temperature coefficient resistors) can be accommodated by exchanging the inputs. Lower impedance sensors may also be used with suitable modifications to the input circuit.

Because the sensing circuit operates on an ac voltage, the signal across the triac can be used as a feedback signal which can be applied to the sensing circuit, either to the junction of the sensing resistor, or the variable resistor (for example via a 10 M $\Omega$  resistor), and in this way enhance, or reduce the hysteresis of the sensing

circuit, and change the switching thresholds depending on whether the triac is ON or OFF.

### 9.12 Common connection to load, triac, and sensor

There may be a need to have the sensor common to both the load and the triac. This permits remote mounting of the sensor and a heater or other load with only three connections. However, that common connection is then live, being connected to active or neutral depending on whether the triac is switched On or OFF.

In such a circuit the AC sensor drive is taken from the AC signal across the triac while the triac is OFF, and from across the load while it is ON, this permits adding an out of balance AC signal into the sensing circuit to increase or decrease the effective hysteresis while the control circuit is cycling.

It should be noted that as there are Mains Voltages on the circuit board adequate labelling should be attached to warn service personnel, and others, that this danger exists.

A control board assembly should be mounted, preferably vertically, with sufficient free air flow across its surface to prevent the heat dissipated in various components from causing an unacceptable rise in the ambient temperature. The triac also needs to have an adequate heatsink, as exceeding its rated maximum junction temperature can result in loss of control, unpredictable behaviour, and possible dangerous conditions.

The board should be mounted in a place that is clean and dry at all times, not subject to condensation or the accumulation of dust and other contaminants.

# Dual sensing precision triac control thermostat

OM1894

## 10 APPLICATION CIRCUITS

A number of circuits are described which explain some of the flexible ways in which the OM1894 can be used.

These provide calculated figures for the input circuit components because these are not determined by the load current, and the width of the gate pulse needed, and therefore the size of the power supply resistor(s) required.

These values in the input bridge circuits have been calculated with the aid of spread sheets which can be used to offer other trip temperatures. These spread sheet files are available from IES. Also any questions which may assist in design of circuits for

other functions can be addressed to IES (telephone, mail, email or fax?). See the IES contact details on the last page of this specification.

### 10.1 Dual sensor thermostat

The circuit of the dual sensor refrigerator thermostat is shown in Figure 5.

This circuit uses a manually adjustable cabinet temperature which can be set to a maximum cut-in temperature of 8 degrees Celsius. The minimum set temperature is 0 degrees, with the cut-out temperatures 2 degrees less. a further temperature sensor is mounted on the evaporator. This has fixed temperatures with a cut-in of 4 degrees, and cut-out of -12.

The internal logic in the OM1894 control IC is such that a compression cycle is only allowed to begin when both the cabinet and the evaporator satisfy their respective cut-in threshold. Likewise, cut-out only happens when both sensors have reached their cutout value.

The reset latch ensures that on power-up, the controller is in an off state, so that before the next compression cycle ice has melted from the condensor, and sufficient time will have passed to allow back pressure on the compressor to have dissipated.

An Excel spread sheet analysis of the trip points of this circuit is available from IES (app18941.xls).

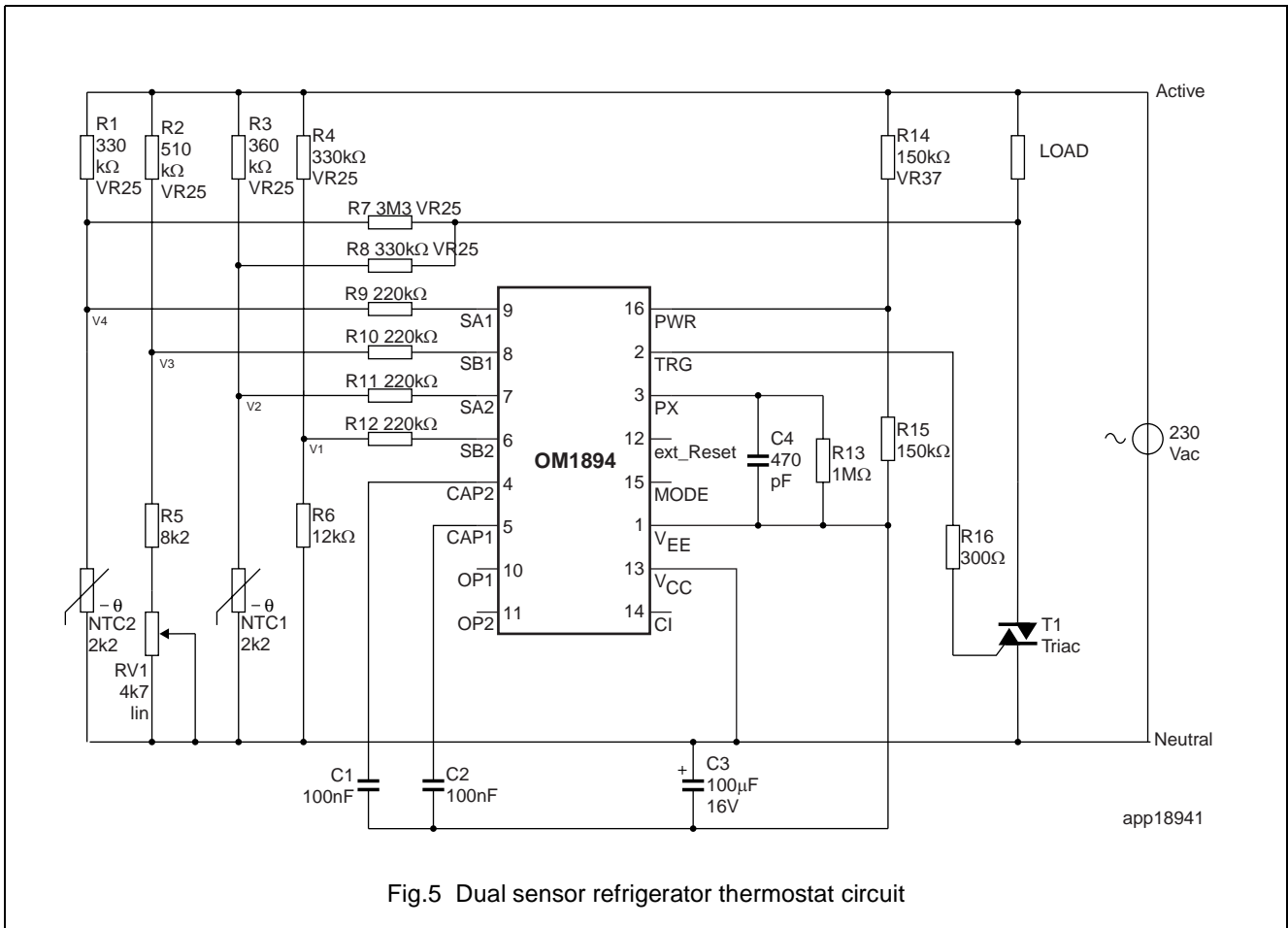

Fig.5 Dual sensor refrigerator thermostat circuit

---

## Dual sensing precision triac control thermostat

---

OM1894

In the dual sensor thermostat where both sensors must be above the cut-in temperature to start a compressor run cycle; and both sensors must be below the cut-out temperature to end the run cycle, the logic is incorporated internally in the OM1894.

Therefore no connection is needed to the two sensing section outputs (OP1 and OP2), no connection to CI, and MODE is left not connected to activate the internal logic circuit.

### 10.2 Dual sensor thermostat with different logic

This circuit is easily connected to demonstrate a different logic function without requiring any additional components.

The following changes are required:

1. Connect MODE to VEE. This means a low on CI is the RUN condition for the triac drive.
2. Connect OP1 and OP2 to CI.
3. Exchange SA1 and SB1 connections. This will invert the operation of the input section, and output low at OP1 will be an ON signal for the triac.
4. Exchange SA2 and SB2 connections.

Exchanging the input connections means that a low signal on OP1 or OP2 indicate that their corresponding thermistors are above their cut-in temperatures.

However these output drive circuits are designed so that when they are connected together, if either circuit has a thermistor colder than its set temperature, then its corresponding OP pin will be pulled high with sufficient current to overwhelm the pull-down signal on the other output, and pull both high.

Therefore this revised configuration of the control shown in Figure 1 will

require both sensors to above their cut-in temperature for a cooling cycle to start, and either sensor to cool below its cut-out temperature to conclude the cooling cycle.

The calculated resistor values remain the same for the trip points, the only change being the revised connections described above.

# Dual sensing precision triac control thermostat

## OM1894

### 10.3 Fixed temperature cut-in thermostat

The circuit of the fixed temperature cut-in refrigerator thermostat is shown in Figure 6.

This circuit uses a single sensor and uses the voltage signal across it to drive each of the two input circuits of the OM1894. The cut-in comparator circuit uses fixed resistors, and therefore operates at a fixed temperature of 3.5 degrees Celsius.

The cut-out temperature employs a variable arm of the sensing bridge to vary the cut-out temperature between -15.5 and -26 degrees.

In this refrigerator the sensor is mounted in close proximity to the

evaporator, hence the low cut-out temperatures.

A spread sheet has been written to show the target temperatures against calculated typical values using the preferred value resistors shown in the circuit below.

The curvature of the control characteristic temperature against potentiometer setting can be adjusted by using resistors in parallel with the potentiometer. This facility has not been included in the spread sheet model for this circuit for reasons of simplicity. However it is easy to incorporate parallel resistors in the model, and to see in the graph given in the sheet how the curvature is IES for assistance if this approach is required.

As in the previous circuit example the triac is turned ON (cut-in) when both input circuits generate an ON output: and only turns OFF when both have reached their OFF trip points.

Note that no feedback is needed from the triac T2.

If the resistor values are changed so that the constant temperature line falls completely below the sloping line, this circuit becomes a constant cut-out thermostat. This is because the symmetry of the input circuits and the ON/OFF logic. The switch ON reset is applied to start the control in the OFF state.

An Excel spread sheet analysis of the trip points of this circuit is available from IES (app18942.xls).

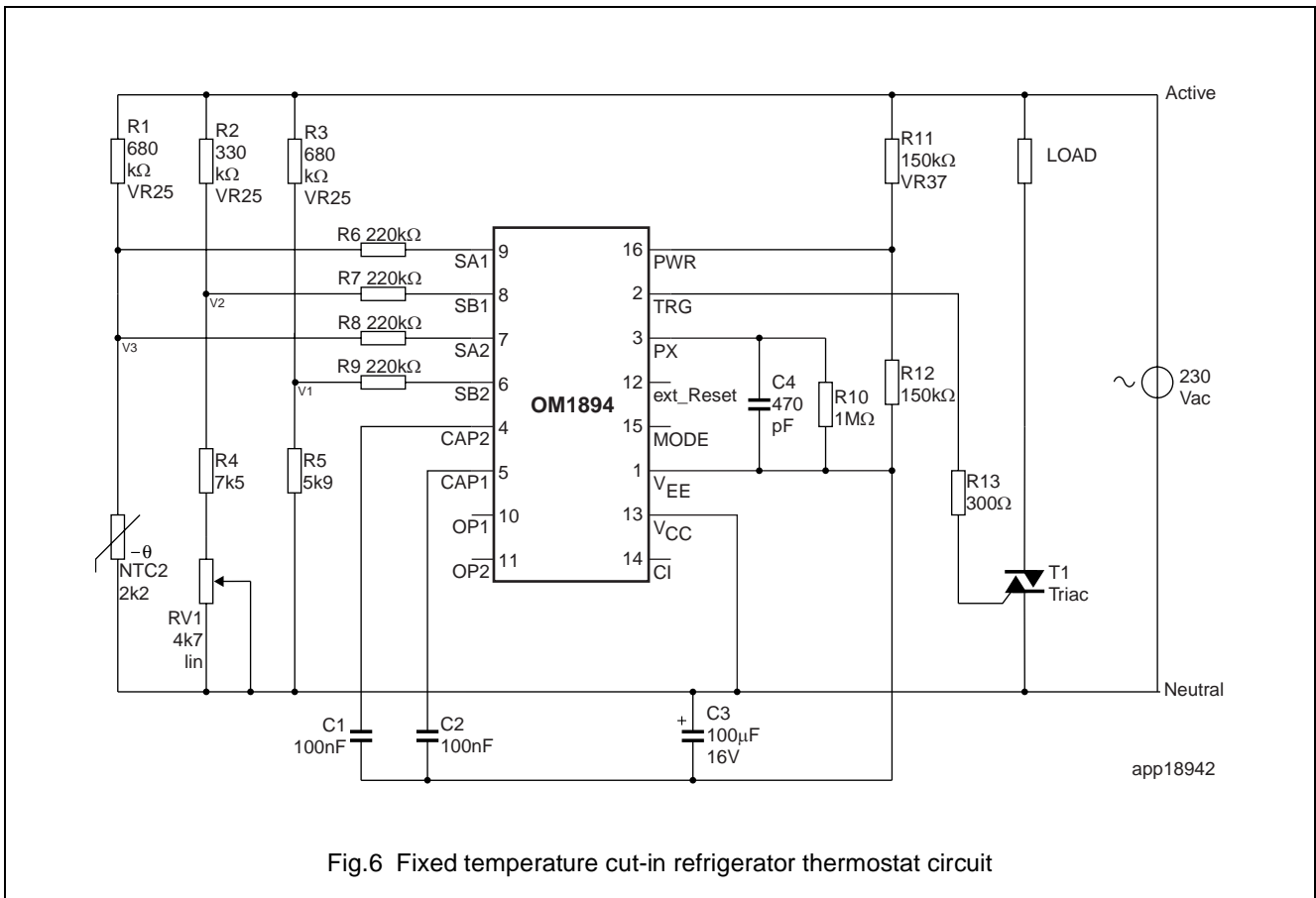

Fig.6 Fixed temperature cut-in refrigerator thermostat circuit



# Dual sensing precision triac control thermostat

OM1894

## 10.4 Variable cut-in and cutout thermostat

The circuit of a refrigerator thermostat in which a single control varies both the cut-in and the cut-out temperatures together is shown in Figure 7.

As in the previous application circuits, the two input circuits are used to control the cut-in and the cut-out points, using the internal logic of the OM1894 when MODE is not connected, to provide the control signal for the triac. That is, a compression cycle is started (cut-in) when the outputs of both input circuit 1 and input circuit 2 are in the ON

state; and the cycle is ended (cut-out) when both circuits have switched to an OFF state.

In this circuit the target temperatures were as follows: cut-in with potentiometer on its coldest setting was 3 degrees Celsius, with cut-out at -23 degrees. On the warmest setting cut-in was 8 degrees with -13 degrees cut-out.

There is considerable interaction between the values used for the resistors and the resulting trip points because the potentiometer is used for both the cut-in and the cut-out curve. It may therefore be difficult to get exact targeted temperatures using

the preferred range of resistor values. However, with some understanding of how these signals interact it is possible to get close to a target set of temperatures. Series or parallel combinations may be used to make finding the required value a little easier.

An Excel spread sheet analysis of the trip points of this circuit is available from IES (app18943.xls).

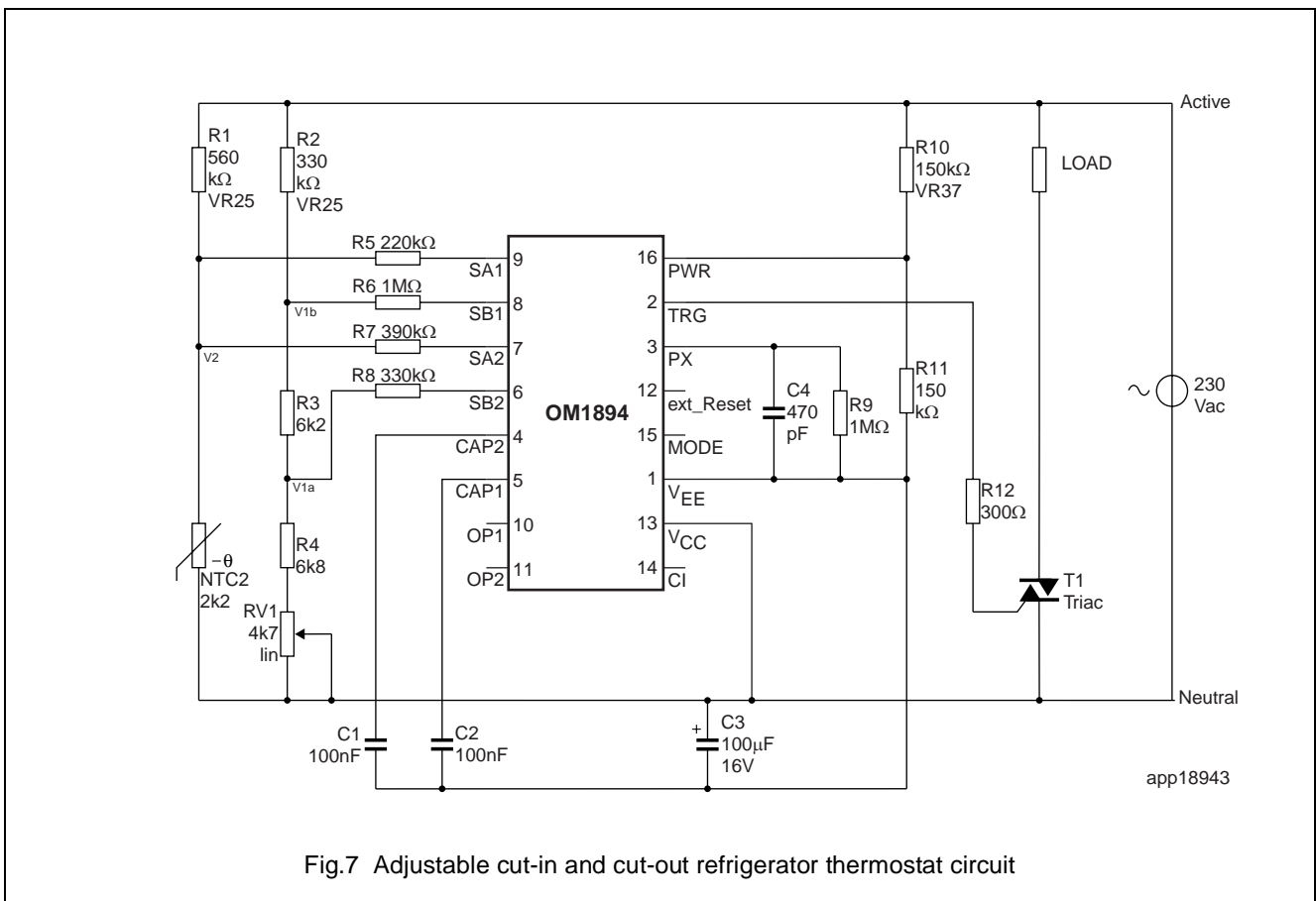

Fig.7 Adjustable cut-in and cut-out refrigerator thermostat circuit

# Dual sensing precision triac control thermostat

OM1894

## 10.5 Freezer thermostat with over-temperature alarm

This circuit shows a freezer thermostat in which a single control varies both the cut-in and the cut-out temperatures together. The potentiometer can vary the cut-in temperature from  $-4$  to  $-10$  degrees, and cut-out from  $-14$  to  $-26$  degrees Celsius. It also includes an over temperature alarm which lights a neon indicator if the cabinet temperature is greater than the set trip point of  $-2$  degrees. It is shown in Figure 8.

Because the voltage across the thermistor is used for the fixed

temperature over temperature indicator, feedback from triac T2 cannot be used across the thermistor; otherwise the voltage across the thermistor would vary in a way that depends on whether the triac is ON or OFF.

Therefore feedback from the triac is converted to an input current and applied to SA1 in addition to the current from across the thermistor.

The output signal from the alarm input circuit is used to normally hold the gate of an SCR low. When the SCR is ON a neon indicator is driven with half wave DC. This will mean the cathode glow of the neon will only occur on

one electrode, and not both as is normal when driven by a full wave AC signal.

The thermistor voltage is applied via R6 to SA1, so OP1 is OFF low when the cabinet temperature is less than the set temperature. Therefore MODE is connected to  $V_{CC}$  to be active high.

For the alarm, a low voltage on OP2 turns the SCR OFF (T1 and T2 are turned ON holding the gate of the SCR low). Therefore SA2 should be connected to the NTC input.

An Excel spread sheet analysis of the trip points of this circuit is available from IES (app18944.xls).

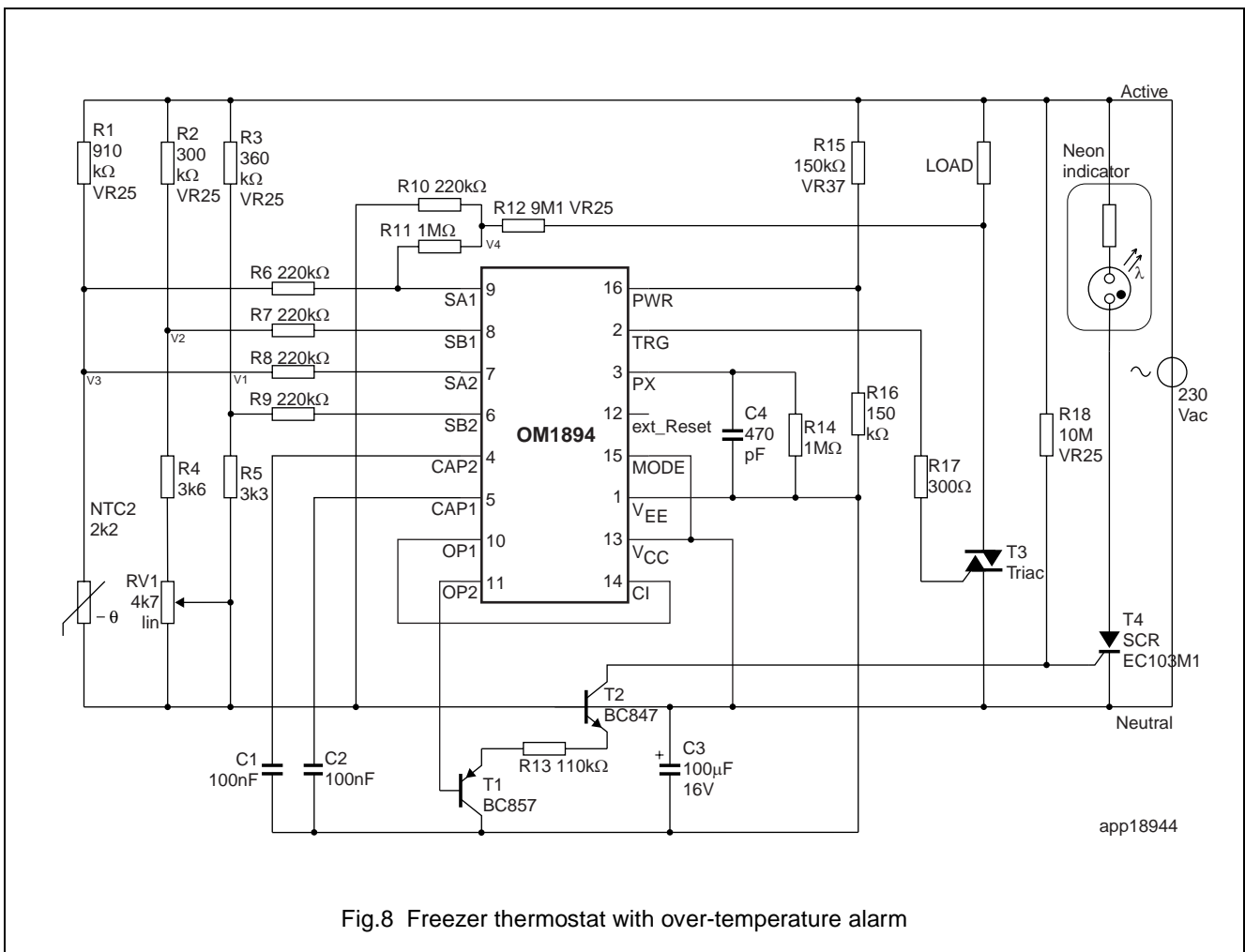

Fig.8 Freezer thermostat with over-temperature alarm



# Dual sensing precision triac control thermostat

## OM1894

### 10.7 Food warming plate with two sensors and single heater

This circuit shows a fixed temperature thermostat which senses the temperature at two positions under the hot plate. One is the warm position (set to 50 Celsius), and the other is for the hot region set to 70 degrees. If either sensing position is below its set temperature the heater is turned on. When both have reached temperature the heater turns off. The circuit is shown in Figure 10.

The two input circuit output pins (OP1 and OP2) are connected together so that if either is pulled high into the ON state this common connection is high. This is connected to the control input CI, and MODE is connected to V<sub>CC</sub> so

that when CI is high, the triac will be on.

A temperature setting potentiometer has not been included simply to show how a fixed temperature input is arranged (also greatly simplifying the spread sheet calculation). All the other examples have temperature adjustment.

This example is for a heating control, so unlike the examples for refrigerative control, the NTC resistance will fall when power is applied to the load. Thus when calling for heat the voltage across the thermistors will be higher, and the NTC signals must be applied to the SB inputs. When compared with the examples for refrigeration the SA and

SB inputs have been exchanged in this example.

The Excel spread sheet analysis of the trip points for this circuit is available. (See spread sheet app18946.xls available from IES).

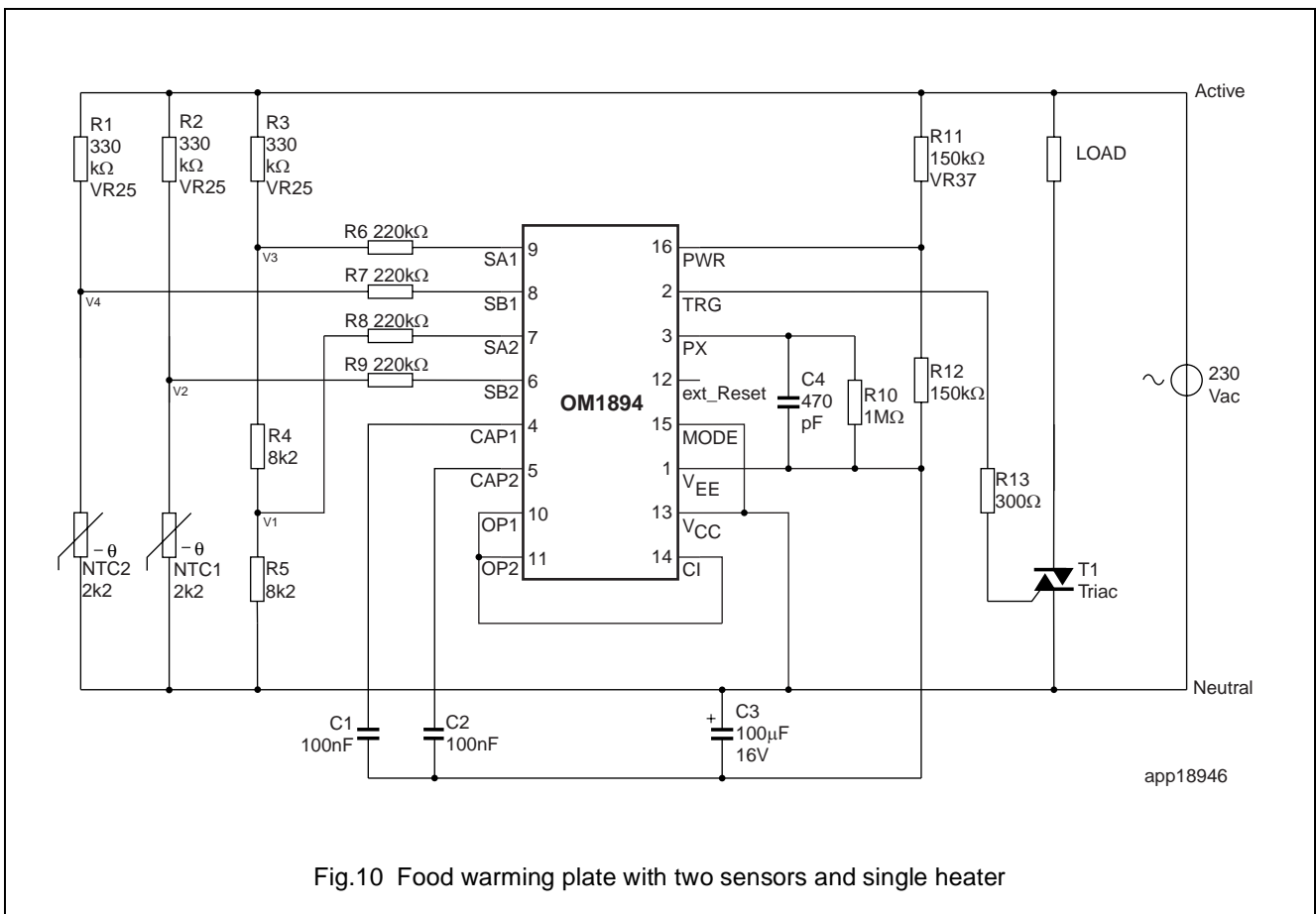

Fig.10 Food warming plate with two sensors and single heater

# Dual sensing precision triac control thermostat

OM1894

## 11 PACKAGE OUTLINES

SO16: plastic small outline package; 16 leads; body width 3.9 mm

SOT109-1

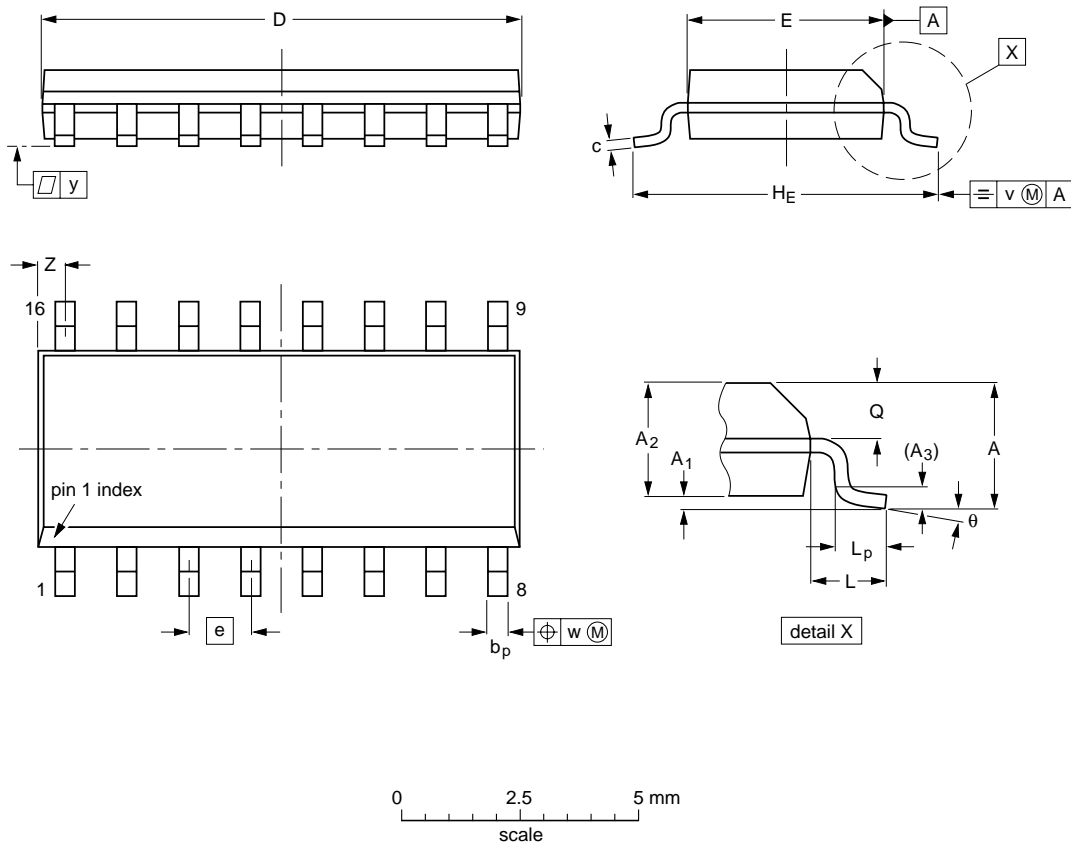

DIMENSIONS (inch dimensions are derived from the original mm dimensions)

UNIT	A max.	A <sub>1</sub>	A <sub>2</sub>	A <sub>3</sub>	b <sub>p</sub>	c	D <sup>(1)</sup>	E <sup>(1)</sup>	e	H <sub>E</sub>	L	L <sub>p</sub>	Q	v	w	y	Z <sup>(1)</sup>	θ
mm	1.75	0.25 0.10	1.45 1.25	0.25	0.49 0.36	0.25 0.19	10.0 9.8	4.0 3.8	1.27	6.2 5.8	1.05	1.0 0.4	0.7 0.6	0.25	0.25	0.1	0.7 0.3	8° 0°
inches	0.069	0.010 0.004	0.057 0.049	0.01	0.019 0.014	0.0100 0.0075	0.39 0.38	0.16 0.15	0.050	0.244 0.228	0.041	0.039 0.016	0.028 0.020	0.01	0.01	0.004	0.028 0.012	

**Note**

1. Plastic or metal protrusions of 0.15 mm maximum per side are not included.

OUTLINE VERSION	REFERENCES			EUROPEAN PROJECTION	ISSUE DATE
	IEC	JEDEC	EIAJ		
SOT109-1	076E07S	MS-012AC			95-01-23- 97-05-22

# Dual sensing precision triac control thermostat

OM1894

DIP16: plastic dual in-line package; 16 leads (300 mil); long body

SOT38-1

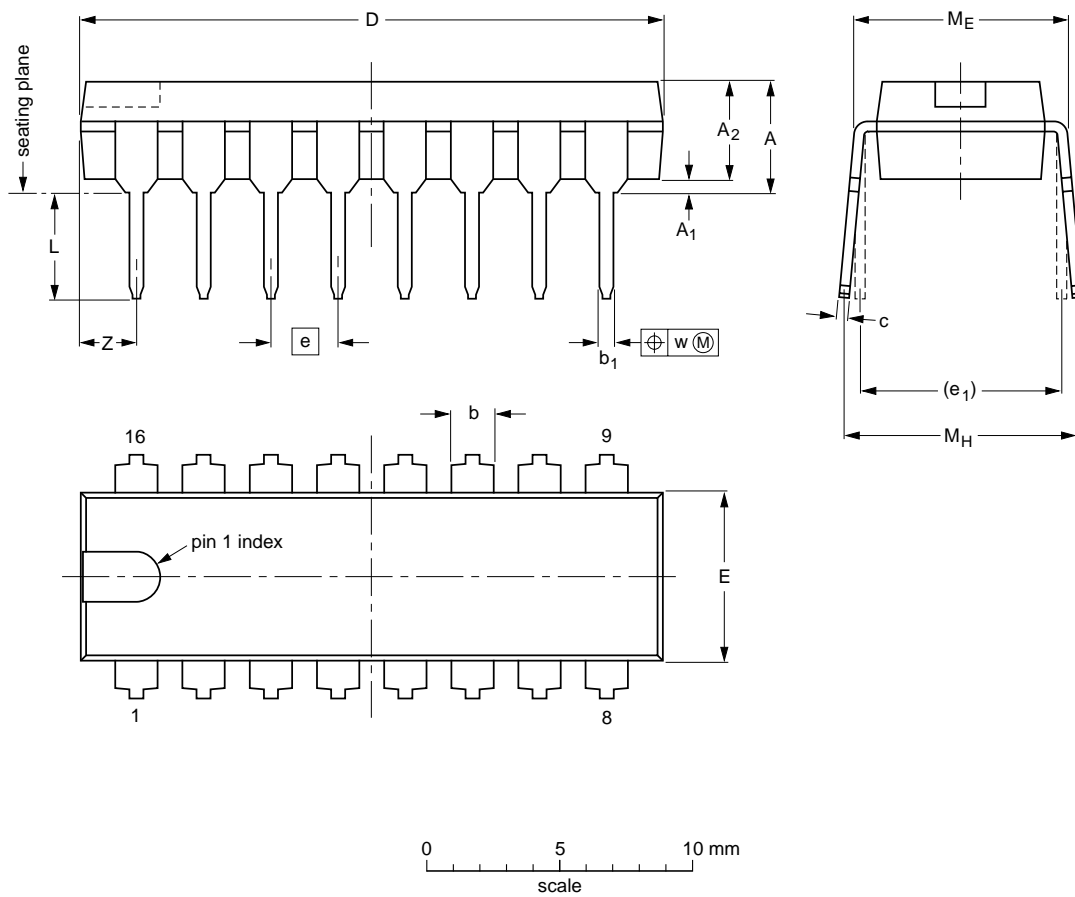

**DIMENSIONS (inch dimensions are derived from the original mm dimensions)**

UNIT	A max.	A <sub>1</sub> min.	A <sub>2</sub> max.	b	b <sub>1</sub>	c	D <sup>(1)</sup>	E <sup>(1)</sup>	e	e <sub>1</sub>	L	M <sub>E</sub>	M <sub>H</sub>	w	Z <sup>(1)</sup> max.
mm	4.7	0.51	3.7	1.40 1.14	0.53 0.38	0.32 0.23	21.8 21.4	6.48 6.20	2.54	7.62	3.9 3.4	8.25 7.80	9.5 8.3	0.254	2.2
inches	0.19	0.020	0.15	0.055 0.045	0.021 0.015	0.013 0.009	0.86 0.84	0.26 0.24	0.10	0.30	0.15 0.13	0.32 0.31	0.37 0.33	0.01	0.087

**Note**

1. Plastic or metal protrusions of 0.25 mm maximum per side are not included.

OUTLINE VERSION	REFERENCES				EUROPEAN PROJECTION	ISSUE DATE
	IEC	JEDEC	EIAJ			
SOT38-1	050G09	MO-001AE				92-10-02 95-01-19

## Dual sensing precision triac control thermostat

OM1894

### 12 SOLDERING

#### 12.1 Introduction

There is no soldering method that is ideal for all IC packages. Wave soldering is often preferred when through-hole and surface mounted components are mixed on one printed-circuit board. However, wave soldering is not always suitable for surface mounted ICs, or for printed-circuits with high population densities. In these situations reflow soldering is often used.

This text gives a very brief insight to a complex technology. A more in-depth account of soldering ICs can be found in our *"IC Package Data book"* (order code 9398 652 90011).

#### 12.2 DIP

##### 12.2.1 SOLDERING BY DIPPING OR BY WAVE

The maximum permissible temperature of the solder is 260 °C; solder at this temperature must not be in contact with the joint for more than 5 seconds. The total contact time of successive solder waves must not exceed 5 seconds.

The device may be mounted up to the seating plane, but the temperature of the plastic body must not exceed the specified maximum storage temperature ( $T_{stg\ max}$ ). If the printed-circuit board has been pre-heated, forced cooling may be necessary immediately after soldering to keep the temperature within the permissible limit.

##### 12.2.2 REPAIRING SOLDERED JOINTS

Apply a low voltage soldering iron (less than 24 V) to the lead(s) of the package, below the seating plane or not more than 2 mm above it. If the temperature of the soldering iron bit is less than 300 °C it may remain in contact for up to 10 seconds. If the bit temperature is between

300 and 400 °C, contact may be up to 5 seconds.

#### 12.3 SO

##### 12.3.1 REFLOW SOLDERING

Reflow soldering techniques are suitable for all SO packages.

Reflow soldering requires solder paste (a suspension of fine solder particles, flux and binding agent) to be applied to the printed-circuit board by screen printing, stencilling or pressure-syringe dispensing before package placement.

Several techniques exist for reflowing; for example, thermal conduction by heated belt. Dwell times vary between 50 and 300 seconds depending on heating method. Typical reflow temperatures range from 215 to 250 °C.

Preheating is necessary to dry the paste and evaporate the binding agent. Preheating duration: 45 minutes at 45 °C.

##### 12.3.2 WAVE SOLDERING

Wave soldering techniques can be used for all SO packages if the following conditions are observed:

- A double-wave (a turbulent wave with high upward pressure followed by a smooth laminar wave) soldering technique should be used.
- The longitudinal axis of the package footprint must be parallel to the solder flow.
- The package footprint must incorporate solder thieves at the downstream end.

During placement and before soldering, the package must be fixed with a droplet of adhesive. The adhesive can be applied by screen printing, pin transfer or syringe

dispensing. The package can be soldered after the adhesive is cured.

Maximum permissible solder temperature is 260 °C, and maximum duration of package immersion in solder is 10 seconds, if cooled to less than 150 °C within 6 seconds. Typical dwell time is 4 seconds at 250 °C.

A mildly-activated flux will eliminate the need for removal of corrosive residues in most applications.

##### 12.3.3 REPAIRING SOLDERED JOINTS

Fix the component by first soldering two diagonally- opposite end leads. Use only a low voltage soldering iron (less than 24 V) applied to the flat part of the lead. Contact time must be limited to 10 seconds at up to 300 °C. When using a dedicated tool, all other leads can be soldered in one operation within 2 to 5 seconds between 270 and 320 °C.

---

Dual sensing precision triac control  
thermostat

---

OM1894

Notes:



---

Dual sensing precision triac control  
thermostat

---

OM1894

Notes:

---

Dual sensing precision triac control  
thermostat

---

OM1894

Notes:

Dual sensing precision triac control thermostat

OM1894

13 DEFINITIONS

<b>Data sheet status</b>	
Engineering sample information	This contains draft information describing an engineering sample provided to demonstrate possible function and feasibility. Engineering samples have no guarantee that they will perform as described in all details.
Objective specification	This data sheet contains target or goal specifications for product development. Engineering samples have no guarantee that they will function as described in all details.
Preliminary specification	This data sheet contains preliminary data; supplementary data may be published later. Products to this data may not yet have been fully tested, and their performance fully documented.
Product specification	This data sheet contains final product specifications.
<b>Limiting values</b>	
Limiting values given are in accordance with the Absolute Maximum Rating System (IEC 134). Stress above one or more of the limiting values may cause permanent damage to the device. These are stress ratings only and operation of the device at these or at any other conditions above those given in the Characteristics sections of the specification is not implied. Exposure to limiting values for extended periods may affect device reliability.	
<b>Application information</b>	
Where application information is given, it is advisory and does not form part of the specification.	

14 IES INFORMATION

INTEGRATED ELECTRONIC SOLUTIONS PTY. LTD.  
 ABN 17 080 879 616

Postal address:

Integrated Electronic Solutions  
 PO Box 2226  
 Port Adelaide SA 5015  
 AUSTRALIA

Street Address:

Integrated Electronic Solutions  
 1 Butler Drive  
 Hendon SA 5014  
 AUSTRALIA

Telephone: +61 8 8348 5200  
 Facsimile: +61 8 8243 1048

World Wide Web: [www.ies-sa.com](http://www.ies-sa.com)

Email: [IES@ies.sa.com.au](mailto:IES@ies.sa.com.au)

---

## Dual sensing precision triac control thermostat

---

OM1894

### 15 DISCLAIMER

Integrated Electronic Solutions Pty. Ltd. ABN 17 080 879 616 ("IES") reserves the right to make changes to both its products and product data without notice.

IES makes no warranty, representation or guarantee regarding the suitability of its products for any particular purpose, nor does IES assume any liability arising out of the use or application of any IES product. IES specifically disclaims any and all liability, including without limitation incidental or consequential damages.

Typical performance figures, where quoted may depend on the application and therefore must be validated by the customer in each particular application. It is the responsibility of customers to ensure that any designs using IES products comply with good practice, applicable standards and approvals. IES accepts no responsibility for incorrect or non-compliant use of its products, failure to meet appropriate standards and approvals in the application of IES products, or for the correct engineering choice of other connected components, layout and operation of IES products.

Any customer purchasing or using IES product(s) for an unintended or unauthorised application shall indemnify and hold IES and its officers, employees, related companies, affiliates and distributors harmless against all claims, costs, damages, expenses, and reasonable legal fees arising out of, directly or indirectly, any claim of loss, personal injury or death associated with such unintended or unauthorised use, even if such claim alleges that IES was negligent regarding the design or manufacture of the relevant product(s).

#### Life Support Applications

Products of Integrated Electronic Solutions Pty Ltd (IES) are not designed for use in life support appliances, devices or systems, where malfunction can result in personal injury. Customers using or selling IES products for use in such applications do so at their own risk and agree to fully indemnify IES for any damages resulting from such improper use or sale.