

32-Channel 128-Level Amplitude Gray-Shade Display Column Driver

Ordering Information

Device	Package Option
	64-Lead 3-sided Plastic Gullwing
HV633	HV633PG

Features

- 5V CMOS inputs
- Up to 80V modulation voltage
- Capable of 128 levels of gray shading
- 24MHz data throughput rate
- 32 outputs per device (can be cascaded)
- Pin-programmable shift direction (DIR)
- D/A conversion cycle time is 20 μ s
- Diodes in output structure allow usage in energy recovery systems
- Integrated HVCMOS[®] technology
- Available in 3-sided 64-lead gullwing package

Absolute Maximum Ratings

Supply voltage, V_{DD} ¹	-0.5V to +7.5V
Supply voltage, V_{PP} ¹	-0.5V to +90V
Logic input levels ¹	-0.5 to V_{DD} + 0.5V
Ground current ²	1.5A
Continuous total power dissipation ³	1W
Operating temperature range	-40°C to +70°C
Storage temperature range	-65°C to +150°C
Lead temperature 1.6mm (1/16 inch) from case for 10 seconds	260°C

Notes:

1. All voltages are referenced to GND.
2. Duty cycle is limited by the total power dissipated in the package.
3. For operation above 25°C ambient derate linearly to 70°C at 22.2mW/°C.

General Description

The HV633 is a 32-channel driver IC for gray shade display use. It is designed to produce varying output voltages between 3 and 80 volts. This amplitude modulation at the output is facilitated by an external ramp voltage V_R . See Theory of Operation for detailed explanation.

This device consists of a dual 16-bit shift registers, 32 data latches and comparators, and control logic to preform 128 levels of gray shading. There are 7 bits of data inputs. Data is shifted through the shift registers at both edges of the clock, resulting a data transfer rate of twice of the shift clock frequency. When the DIR pin is high, CSI/CSO is the input/output for the chip select pulse. When DIR is low, CSI/CSO is the output/input for the chip select pulse. The DIR = HIGH also allows the HV633 to shift data in the counter-clockwise direction when viewed from the top of the package. When the DIR pin is low, data is shifted in the clockwise direction.

The output circuitry allows the energy which is stored in the output capacitance to be returned to V_{PP} through the body diode of the output transistor.

Electrical Characteristics (at $T_A = 25^\circ\text{C}$, over operating conditions unless otherwise specified)

Low-Voltage DC Characteristics (Digital)

Symbol	Parameter	Min	Typ ¹	Max	Units	Conditions
I_{DD}	V_{DD} supply current		12	20	mA	$f_{SC} = 12\text{MHz}$ $f_{CC} = 12\text{MHz}$
I_{DDQ}	Quiescent V_{DD} supply current			200	μA	All $V_{IN} = 0\text{V}$, $V_{DD} = \text{max}$
I_{IH}	High-level input current		1.0	50	μA	$V_{IH} = V_{DD}$
I_{IL}	Low-level input current		-1.0	-50	μA	$V_{IL} = 0\text{V}$
C_{IN}^2	Input capacitance (data, LC, SC, CC)			15	pF	$V_{IN} = 0\text{V}$, $f = 1.0\text{MHz}$
I_{OH}	High-level output current	-2.0			mA	$V_{DD} = 4.5\text{V}$
I_{OL}	Low-level output current	2.0			mA	$V_{DD} = 4.5\text{V}$

Notes

- All typical values are at $V_{DD} = 5.0\text{V}$.
- Guaranteed by design.

Low-Voltage DC Characteristics (Analog)

Symbol	Parameter	Min	Typ	Max	Units	Conditions
I_{DD}	V_{DD} supply current			500	μA	$f_{SC} = 12\text{MHz}$ $f_{CC} = 12\text{MHz}$
I_{DDQ}	Quiescent V_{DD} supply current			200	μA	All $V_{IN} = 0\text{V}$, $V_{DD} = \text{max}$

High-Voltage Bias Circuit for Output Variation Control

Symbol	Parameter	Min	Typ	Max	Units	Conditions
I_{PP}	V_{PP} supply current for bias circuit		2.0		mA	Depending on external bias circuit, see Table 1.

High-Voltage DC Characteristics

Symbol	Parameter	Min	Typ	Max	Units	Conditions
I_{AOH}	High-voltage analog output source current	See Performance Curves			mA	$V_{PP} = 80\text{V}$ See test circuit
I_{AOL}	High-voltage analog output sink current	See Performance Curves			mA	$V_{PP} = 80\text{V}$, $V_{DD} = 4.5\text{V}$ $V_{AO} = 2.0\text{V}$
ΔV_O	Maximum delta voltage between high voltage outputs of the same level			± 0.2	V	At all gray levels

Recommended Operating Conditions

Symbol	Parameter	Min	Typ	Max	Units
V_{DD}	Low-voltage digital supply voltage	4.5	5.0	5.5	V
V_{DD}	Low-voltage analog supply voltage	4.5	5.0	5.5	V
V_{IH}	High-level input voltage (analog and digital)	$V_{DD} - 1$		V_{DD}	V
V_{IL}	Low-level input voltage (analog and digital)	0		1.0	V
V_{BIAS}	I_{PP} control circuit bias voltage	-2.0	0		V
V_{CTL}	I_{PP} control circuit control voltage		0	2.0	V
V_{PP}	High-voltage supply	-0.3		80	V
V_R	Ramp voltage	0		$V_{PP} - 2$	V
f_{SC}	Shift clock operating frequency (at $V_{DD} = 5.5\text{V}$)			12	MHz
T_A	Operating free-air temperature	-40		70	$^\circ\text{C}$

Notes:

Power-up sequence should be the following:

- Connect ground.
- Apply V_{DD} .
- Set all inputs (Data, CLK, Enable, etc.) to a known state.
- Apply V_{PP} .

Power-down sequence should be the reverse of the above.

Electrical Characteristics

AC Characteristics ($V_{DD} = 5.5V$, $T_A = 25^\circ C$)

Logic Timing

Symbol	Parameter	Min	Typ	Max	Units	Conditions
f_{SC}	Shift clock operating frequency			12	MHz	
f_{DIN}	Data-in frequency			24	MHz	
t_{SS}	CSI/CSO pulse to shift clock setup time		40		ns	
t_{HS}	CSI/CSO pulse to shift clock hold time		0		ns	
t_{WA}	CSI pulse width		49		ns	
t_{DS}	Data to shift clock setup time		20		ns	
t_{DH}	Data to shift clock hold time		0		ns	
t_{WD}	Data-in pulse width		24		ns	
t_{WLC}	Load count pulse width		98		ns	
t_{DLCR}	Load count to ramp delay	1.0			μs	
t_{DRCC}^1	Ramp to count clock delay	0.47			μs	
t_{DSL}	Shift clock to load count delay time		98		ns	
t_{CSC}	Shift clock cycle time	98			ns	
t_{WSC}	Shift clock pulse width	49			ns	
t_{CCC}	Count clock cycle time	98			ns	
t_{WCC}	Count clock pulse width	49			ns	

Note 1: Count clock starts counting after $0.47\mu s$ min. This is equivalent to a time duration for a linear ramp V_R to ramp from 0 to 3V, assuming the minimum value of T_{RR} , ramp size time of $12\mu s$ for $V_R = 80V$.

V_{RAMP} Timing

Symbol	Parameter	Min	Typ	Max	Units	Conditions
t_{CR}	Cycle time of ramp signal	15			μs	
t_{RR}	Ramp rise time	10.6			μs	
t_{HR}^2	Ramp hold time	2		15	μs	
t_{FR}	Ramp fall time	3			μs	$C_{LOAD}=1nF$

Note 2: The maximum ramp hold time may be longer than $15\mu s$, but the output voltage HV_{OUT} will droop due to leakage.

Table 1:

Schemes to control I_{PP} bias current, typical I_{PP}

Option 1

V_{BIAS} (V)	V_{CTL} (V)	R_{CTL} (Ω)	I_{PP} (mA)
0	0.1	56K	2
0	1.0	56K	7

Option 2

V_{BIAS} (V)	V_{CTL} (V)	R_{CTL} (Ω)	I_{PP} (mA)
-1.0	0	56K	4
-2.0	0	56K	5.5

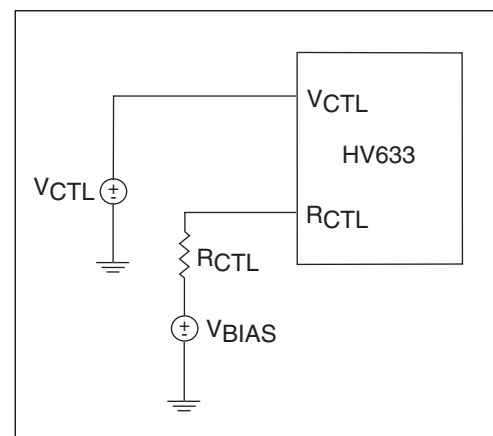

Pin Definitions

Pin #	Name	Function
30-36	D1-D7	Inputs for binary-format parallel data.
26	SC (Shift Clock)	Triggers data on both rising and falling edges. This implies that the data rate is always twice the clock rate (data rate = 20MHz max if clock rate = 10MHz max).
22	CSI (Chip Select Input)	Input pin for the chip select pulse (when DIR is high). Output pin for the chip select pulse (when DIR is low).
43	CSO (Chip Select Output)	Input pin for the chip select pulse (when DIR is low). Output pin for the chip select pulse (when DIR is high).
40	LC (Load Count)	Input for a pulse whose rising edge causes data from the input latches to enter the comparator latches, and whose falling edge initiates the conversion of this binary data to an output level (D-to-A). Also, the HV _{OUT} will clear to zero after the load count is initiated.
42	CC (Count Clock)	Input to the count clock generator whose increments are compared to the data in the comparator latches.
18, 47	V _R	High-voltage ramp input for charging the output stage hold capacitors (C _H). This input can be linear or non-linear as desired.
28	DIR	When this pin is connected to V _{DD} , input data is shifted in ascending order, i.e., corresponding to HV _{OUT} 1 to HV _{OUT} 32. When connected to LVGND, input data is shifted in descending order, i.e., corresponding to HV _{OUT} 32 to HV _{OUT} 1.
27, 38	LVGND	This is ground for the logic section. HVGND and LVGND should be connected together externally.
17, 48	HVGND	This is ground for the high-voltage (output) section. HVGND and LVGND should be connected together externally.
19, 45	V _{PP}	This input biases the output source followers.
1-16 49-64	HV _{OUT} 1- HV _{OUT} 32	High-voltage outputs.
21	V _{DD} (Analog)	Low-voltage analog supply voltage.
29	V _{DD} (Digital)	Low-voltage digital supply voltage.
24	V _{CTL}	Voltage supply pin to prevent output voltage from being affected by its adjacent outputs (V _{CTL} = 2V for a particular panel). The combination of V _{CTL} and R _{CTL} will reduce the output voltage variation to less than ±0.2V of delta voltage between high voltage outputs of the same level at all gray levels.
25	R _{CTL}	Current sense resistor to ground to prevent output voltage from being affected by its adjacent outputs (R _{CTL} = 56KΩ for a particular panel). See V _{CTL} function above.

Input and Output Equivalent Circuits

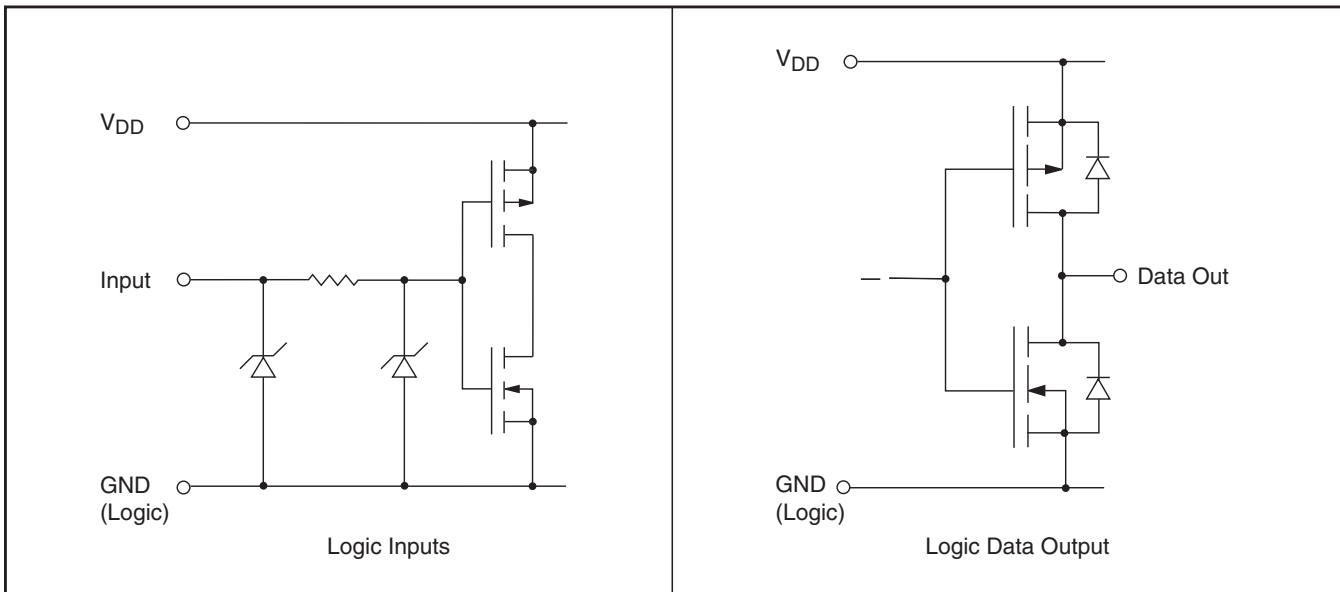

Output Stage Detail

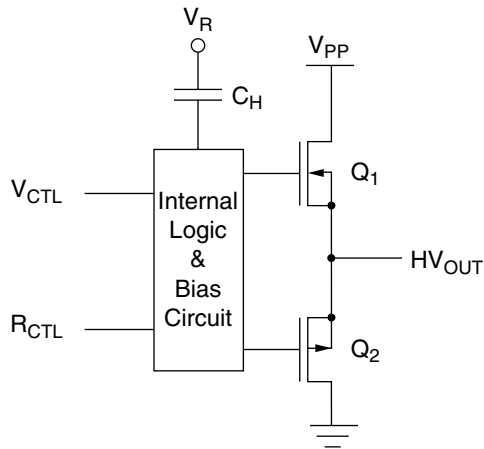

Test Circuit

High-voltage Analog Output Source Current (I_{AOH})
For gray shade #1 (000 0000)

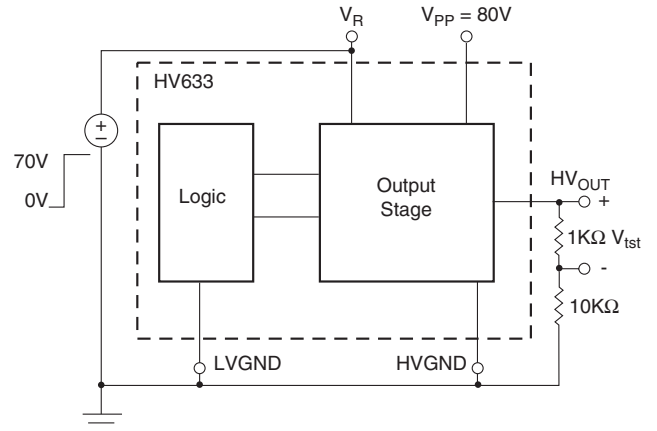

1. Set $HV_{OUT} = \text{Low}$.
2. Apply $V_{PP} = 80V$.
3. Apply a step voltage of 70V at V_R (slew rate = $4.1V/\mu s$).
4. Measure voltage across the 1KΩ resistor.
5. Output source current can be calculated by using $\frac{V_{tst}}{1K}$.

Functional Block Diagram

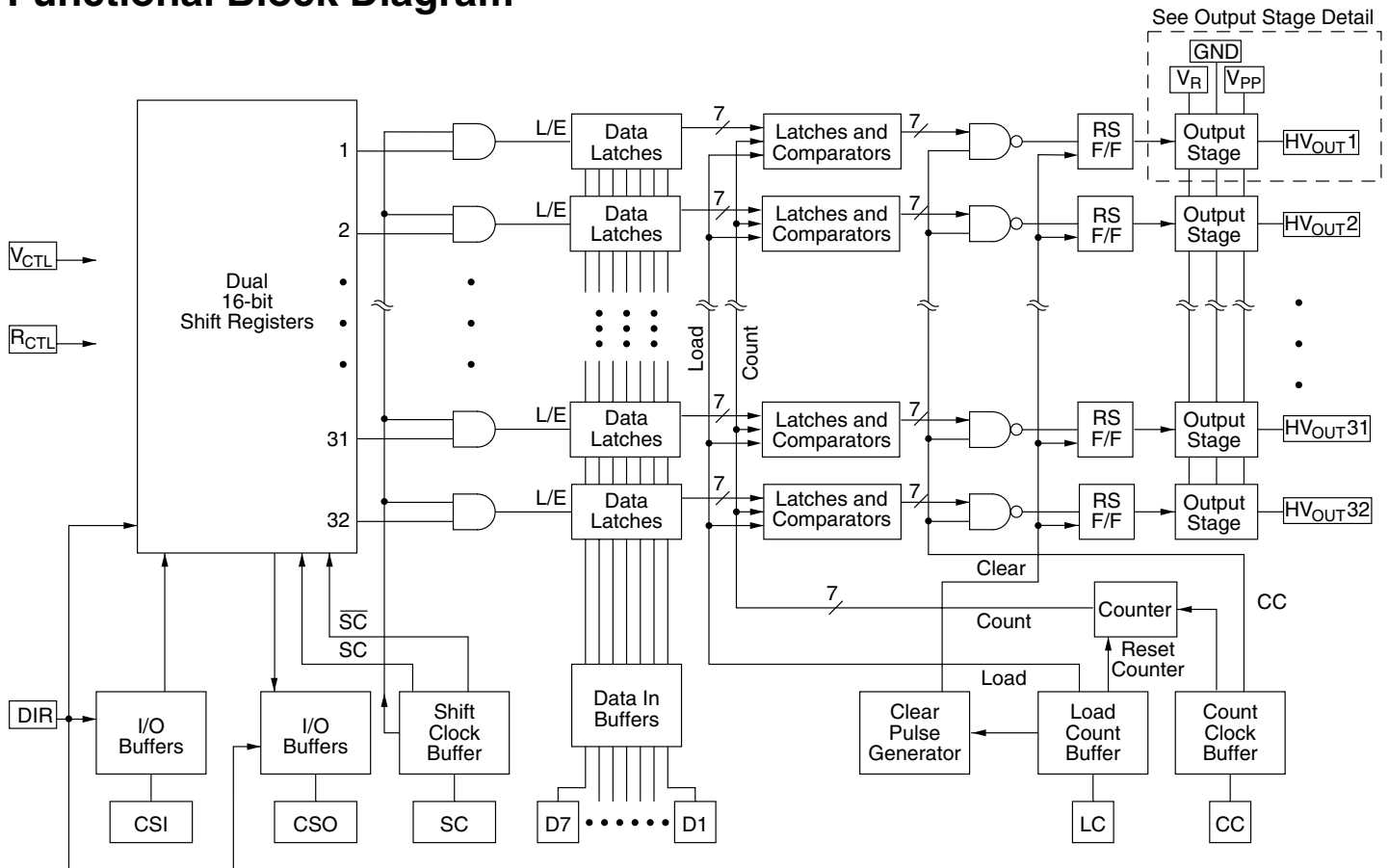

SC = Shift Clock CSI = Chip Select Input
 LC = Load Count CSO = Chip Select Output
 CC = Count Clock *Strobe = twice the SC frequency

Typical Panel Connections

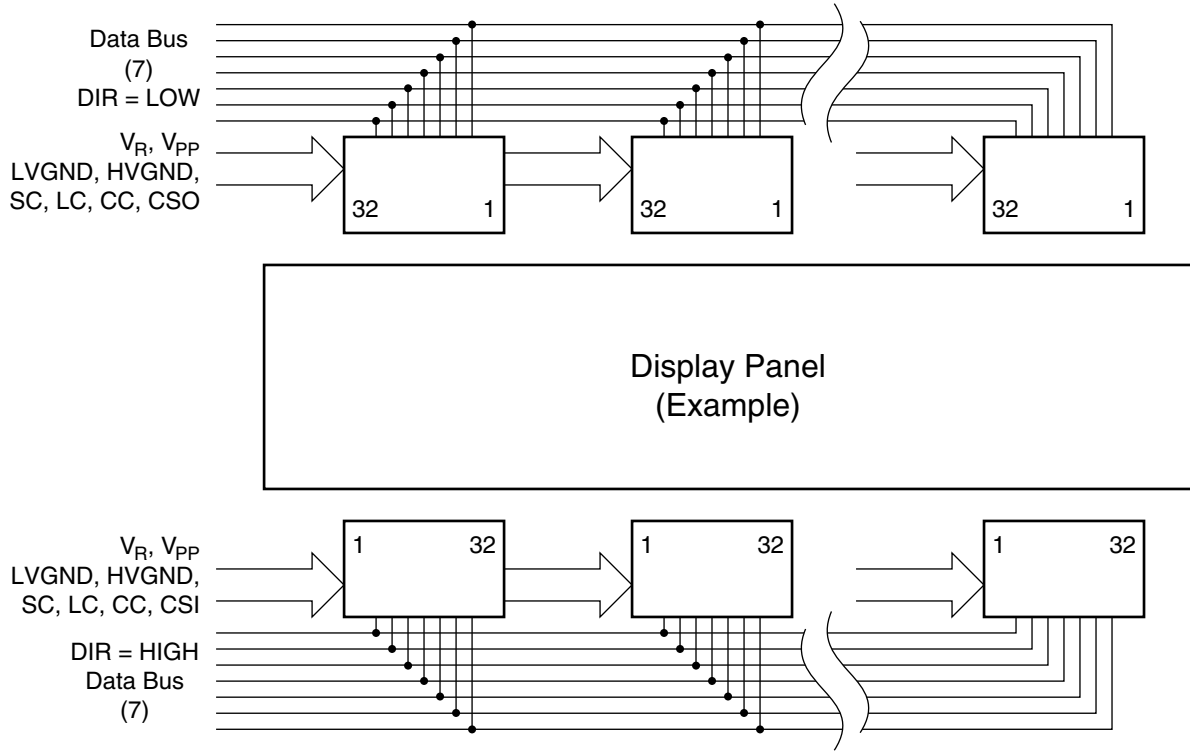

Gray Shade Decoding Scheme

Shade Number	D7	D6	D5	D4	D3	D2	D1
128	1	1	1	1	1	1	1
127	1	1	1	1	1	1	0
126	1	1	1	1	1	0	1
125	1	1	1	1	1	0	0
124	1	1	1	1	0	1	1
123	1	1	1	1	0	1	0
122	1	1	1	1	0	0	1
121	1	1	1	1	0	0	0
...							
7	0	0	0	0	1	1	0
6	0	0	0	0	1	0	1
5	0	0	0	0	1	0	0
4	0	0	0	0	0	1	1
3	0	0	0	0	0	1	0
2	0	0	0	0	0	0	1
1	0	0	0	0	0	0	0

Gray Scale Voltage

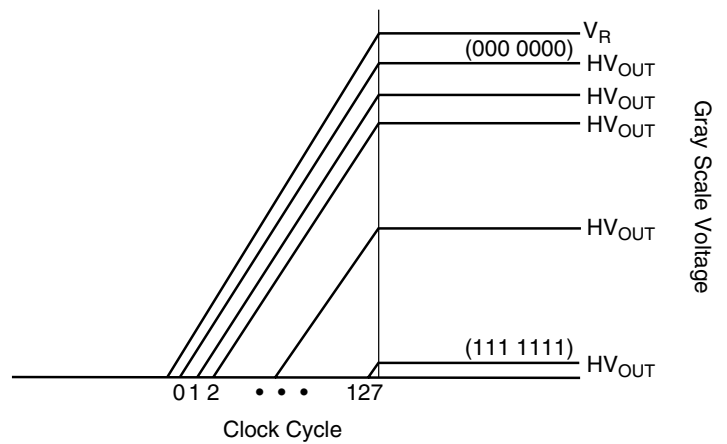

Function Table

Sequence	Function	DIR	Data-In (D1 - D7)	CSI	CSO	Shift Clock	Load Count	Count Clock	V _R	HV _{OUT}
1	Shift Data from HV _{OUT} 1 to 32	H	H		Output		L	L	L	L
			L							H
2	Shift Data from HV _{OUT} 32 to 1	L	H	Output			L	L	L	L
			L							H
3	Load Shift Register	X	X	Pre-define by 1 or 2			L	L	L	-
4	Load Counter	X	X			L		L	L	-
5	Counting/Voltage Conversion	X	X			L	L		Initiates V _{RAMP}	-

Timing Diagrams

(a) Basic System Timing

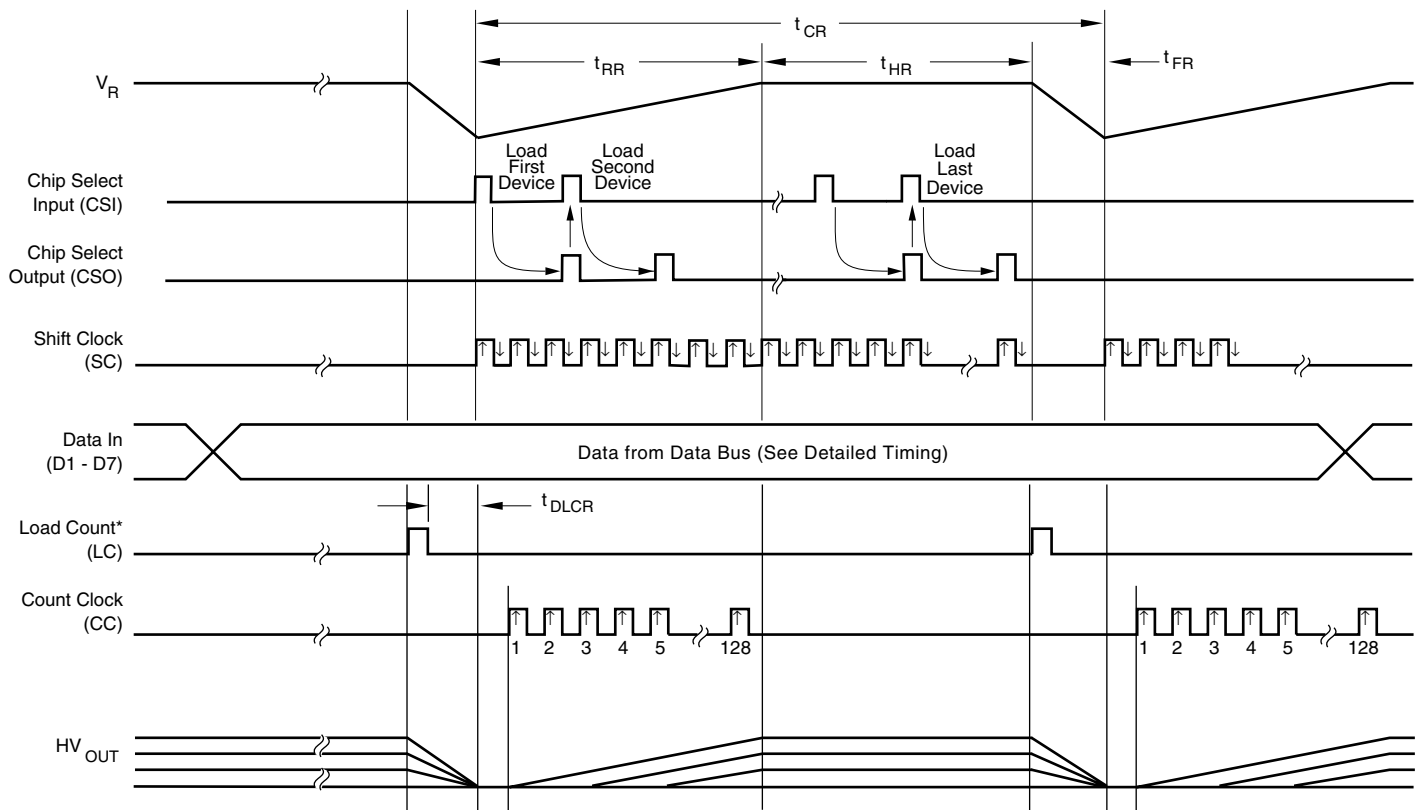

*HV_{OUT} will clear to zero with load count.

(b) Detailed Device Timing

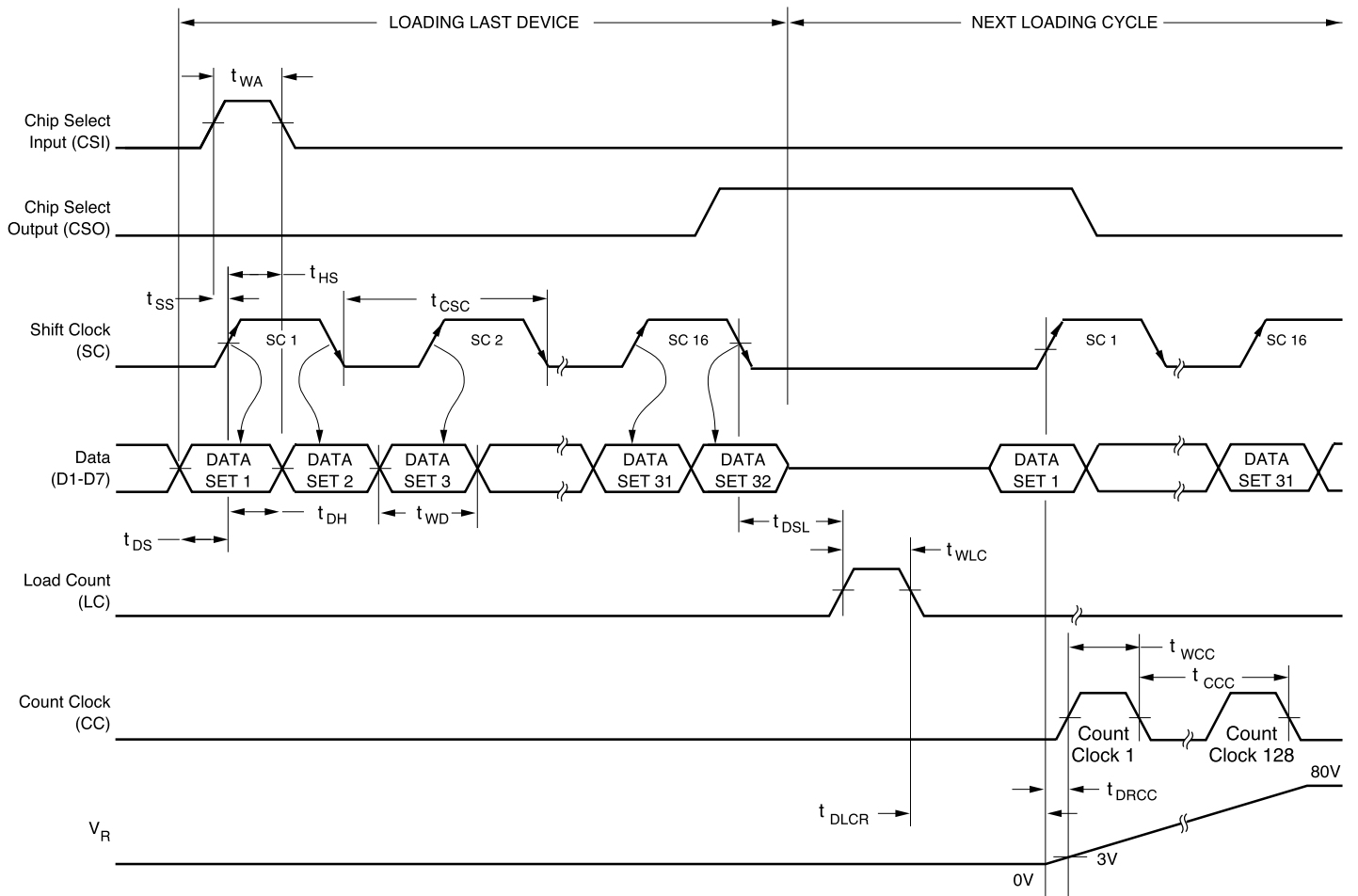

Typical Performance Curves

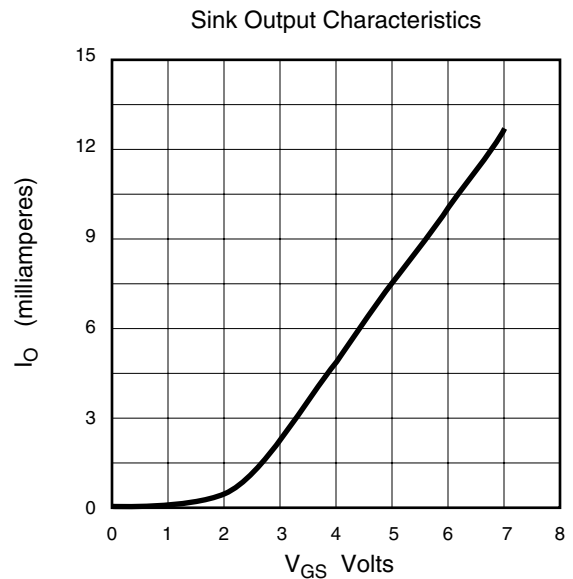
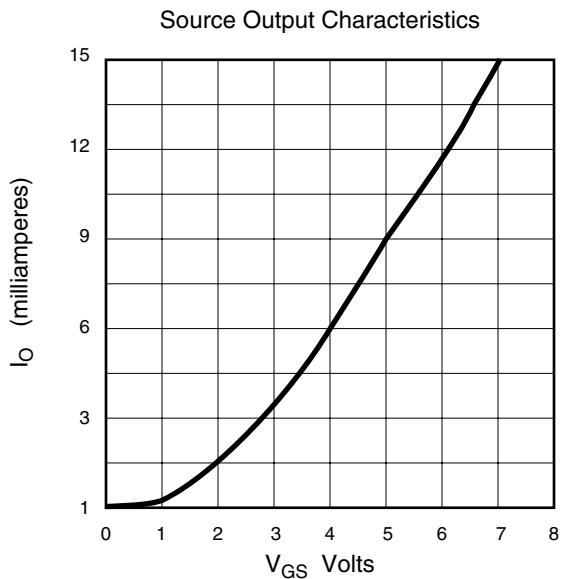

Pin Configuration

64-Pin PG Package

Pin	Function	Pin	Function	Pin	Function
1	HV _{OUT} 1	23	N/C	45	V _{PP}
2	HV _{OUT} 2	24	V _{CTL}	46	N/C
3	HV _{OUT} 3	25	R _{CTL}	47	V _R
4	HV _{OUT} 4	26	SC (Shift Clock)	48	HVGND
5	HV _{OUT} 5	27	LVGND	49	HV _{OUT} 17
6	HV _{OUT} 6	28	DIR	50	HV _{OUT} 18
7	HV _{OUT} 7	29	V _{DD} (Digital)*	51	HV _{OUT} 19
8	HV _{OUT} 8	30	D ₇	52	HV _{OUT} 20
9	HV _{OUT} 9	31	D ₆	53	HV _{OUT} 21
10	HV _{OUT} 10	32	D ₅	54	HV _{OUT} 22
11	HV _{OUT} 11	33	D ₄	55	HV _{OUT} 23
12	HV _{OUT} 12	34	D ₃	56	HV _{OUT} 24
13	HV _{OUT} 13	35	D ₂	57	HV _{OUT} 25
14	HV _{OUT} 14	36	D ₁	58	HV _{OUT} 26
15	HV _{OUT} 15	37	N/C	59	HV _{OUT} 27
16	HV _{OUT} 16	38	LVGND	60	HV _{OUT} 28
17	HVGND	39	N/C	61	HV _{OUT} 29
18	V _R	40	LC (Load Count)	62	HV _{OUT} 30
19	V _{PP}	41	N/C	63	HV _{OUT} 31
20	N/C	42	CC (Count Clock)	64	HV _{OUT} 32
21	V _{DD} (Analog)*	43	CSO		
22	CSI	44	N/C		

* Analog V_{DD} and digital V_{DD} may be connected separately for better noise immunity.

Package Outlines

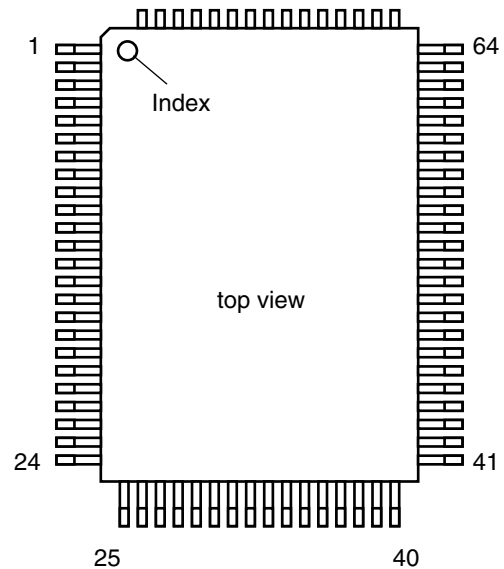

3-Sided Plastic QFP 64-pin Gullwing Package

Theory of Operation

The HV633 has two primary functions:

- 1) Loading data from the data bus and,
- 2) Gray-shade conversion (converting latched data to output voltages).

Since the device was developed initially for flat panel displays, the operation will be described in terms that pertain to that technology. As shown by the Typical Drive Scheme, several HV633 packages are mounted at the top and bottom of a display panel. Data exists on a 7-bit bus (adjacent PC board traces) at top and bottom. The D1 through D7 inputs of each chip take data from the bus when either a CSI or CSO pulse is present at the chip. These pulses therefore act as a combination CHIP SELECT and LOCATION STROBE. Because of the way the chip HV_{OUT} pins are sequenced, data on the bus at the bottom of the display panel will be entered into the left-most chip as HV_{OUT}1, HV_{OUT}2, etc. up to HV_{OUT}32. The CSI pulse will accomplish this with DIR = High.

Loading Data from Data Bus

Here is the full data-entry sequence:

- 1) The microcontroller puts data on the bus (7 bits)
- 2) To enter the data into the 32 sets of 7 latches on the first chip, the shift clock rises. This positive transition is combined with the CSI pulse and is generated only once to strobe the data into the first set of latches. (These latches eventually send data to the HV_{OUT}1). The data on the bus then changes, the shift clock falls, and this negative transition is combined with the CSI pulse, which is now propagated internally, to strobe the new data into the next set of 7 latches (which will end up as HV_{OUT}2). This internal CSI pulse therefore runs at twice the shift clock rate.
- 3) When the last set of 7 latches in the first chip has been loaded (HV_{OUT}32), the CSI pulse leaves chip 1 and enters chip 2. The exit pin is called CSO and the chip 2 entry pin is CSI. For chips at the top of the panel things are reversed: DIR is low, entry pins are CSO and exit pins are CSI, because the data-into-latches sequence is in descending order, HV_{OUT}32 down to HV_{OUT}1.
- 4) The buses may of course be separate, and data can be strobed in on an interleaved basis, etc., but those complications will be left to systems designers.

When data has been loaded into all 32 outputs of all chips (top and bottom of the display panel), the load count pin is pulsed. On its rising transition, all output levels are reset to zero and all the data in the input latches is transferred to a like number of comparator latches, (thus leaving the data latches ready to receive new data during the following operations). After the transfer, the load count pin is brought low. This transition begins the events that convert the binary data into a gray-shade level.

Gray-shade Conversion

- 1) The COUNT CLOCK is started. An external signal is applied to the COUNT CLOCK pin, causing the counter on each chip to increment from binary 000 0000 to 111 1111 (0 to 127).
- 2) At the same time, the V_R voltage is applied to all chips, via charging transistors, causing the HOLD CAPACITOR (C_H) on each output to experience a rise in voltage.
- 3) The logic control compares the count in the comparator latch to the count clock. The gate voltage of Q_1 and the output voltage HV_{OUT} will ramp up at the same rate as V_R .
- 4) Once V_R has reached the maximum voltage, then all the pixels will be at the final value. (See Output Gray Scale Voltage.)

Output Voltage Variation

The output voltage of the HV633 is determined by the logic and the ramp voltage V_R . It is possible that the output voltage may be coupled to an unacceptable level due to its adjacent outputs through the panel. In order to solve this problem, internal logic (refer to Output Stage Detail) is integrated in the IC to minimize the effect.

Two external pins V_{CTL} and R_{CTL} allow the feasibility to control the current flowing through Q_2 . The V_{CTL} pin is connected to a voltage source and the R_{CTL} pin is connected to ground through a resistor (2V and 56K Ω are used for a particular panel). The internal bias circuit will drive the resistor to a voltage level that is equal to the V_{CTL} voltage at steady state through an operational amplifier. The current flowing through Q_1 and Q_2 will be limited to V_{CTL}/R_{CTL} . This combination of V_{CTL} and R_{CTL} will reduce the output voltage variation to less than $\pm 0.2V$ of delta voltage for each gray shade, independent of its adjacent output voltages.