

ASSP

BIPOLAR

1A Motor Drive IC for Motor Applications

MB3853

■ DESCRIPTION

The FUJITSU MB3853 is a motor drive IC with two power driver channels capable of sink/source operation, for use in two-channel independent operation or H-type drive operation.

The control system and output system have independent power supplies, allowing the control system to be set to low-voltage operation to conserve power.

Protective circuits are provided for temperature, overvoltage, and overload current, with an open collector type monitoring terminal.

The MB3853 is designed for use with motors in AV products, office automation products, or cameras, and is also an ideal IC for use in automated vending equipment and other unmanned operating devices.

■ FEATURES

- Circuit configuration
 - Two sets of built-in control circuits and power circuits
 - Built-in fly-back diode
- Functions
 - Can drive two motors independently or in H-type drive configurations
 - Built-in inhibitor function

(Continued)

■ PACKAGE

Plastic SIP, 9 pins

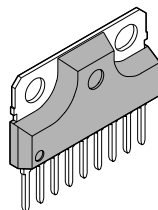

(SIP-9P-M02)

MB3853

(Continued)

- Input/output terminals
Power supply terminals : Independent control system supply terminal and output system supply terminal
Control terminals : TTL level/CMOS level compatible
Monitor terminal : Open collector type
- Space-saving package (SIP9)

■ PIN ASSIGNMENT

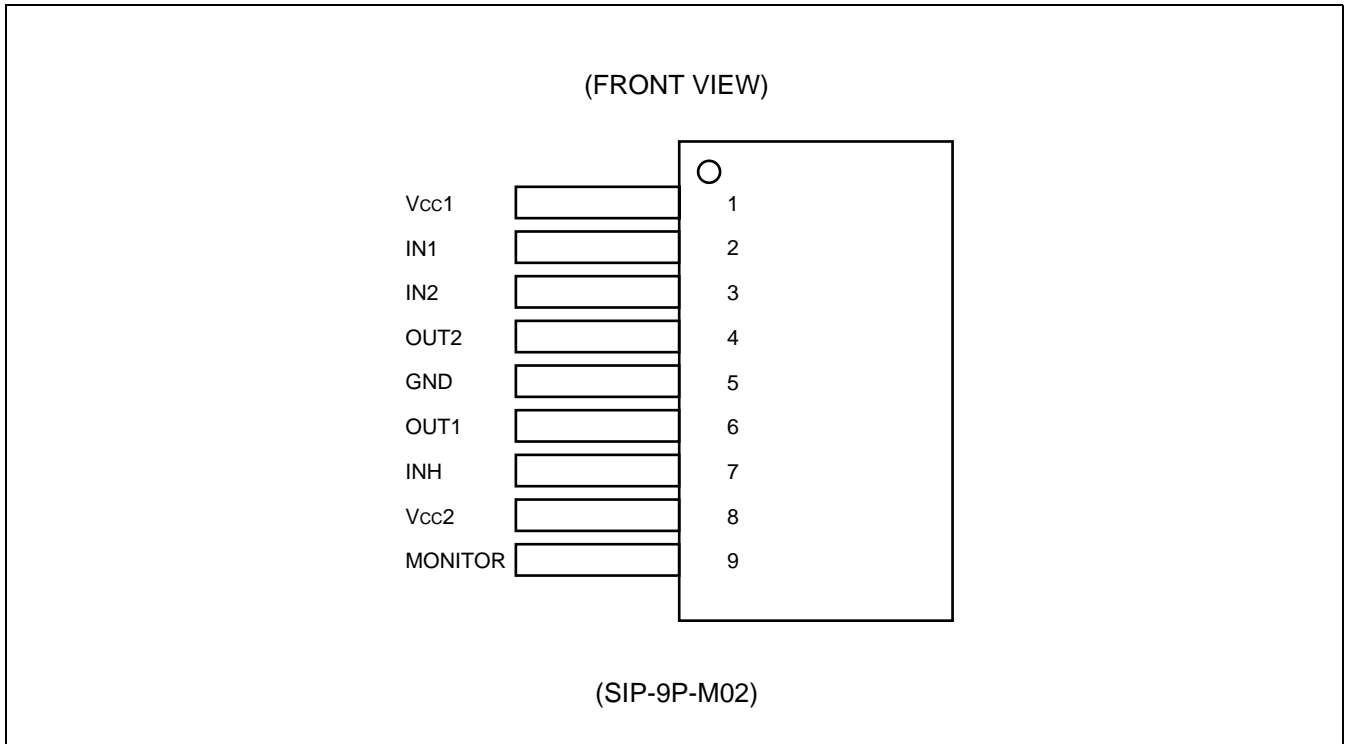

■ PIN DESCRIPTION

Pin no.	Symbol	I/O	Description
1	V _{cc} 1	—	Control system power supply terminal
2	IN1	I	Load control signal input terminal 1
3	IN2	I	Load control signal input terminal 2
4	OUT2	O	Load control output terminal 2
5	GND	—	Ground terminal
6	OUT1	O	Load control output terminal 1
7	INH	I	Inhibitor signal input terminal
8	V _{cc} 2	—	Output system power supply terminal
9	MONITOR	O	Protective circuit motor signal output terminal (open collector type terminal)

■ BLOCK DIAGRAM

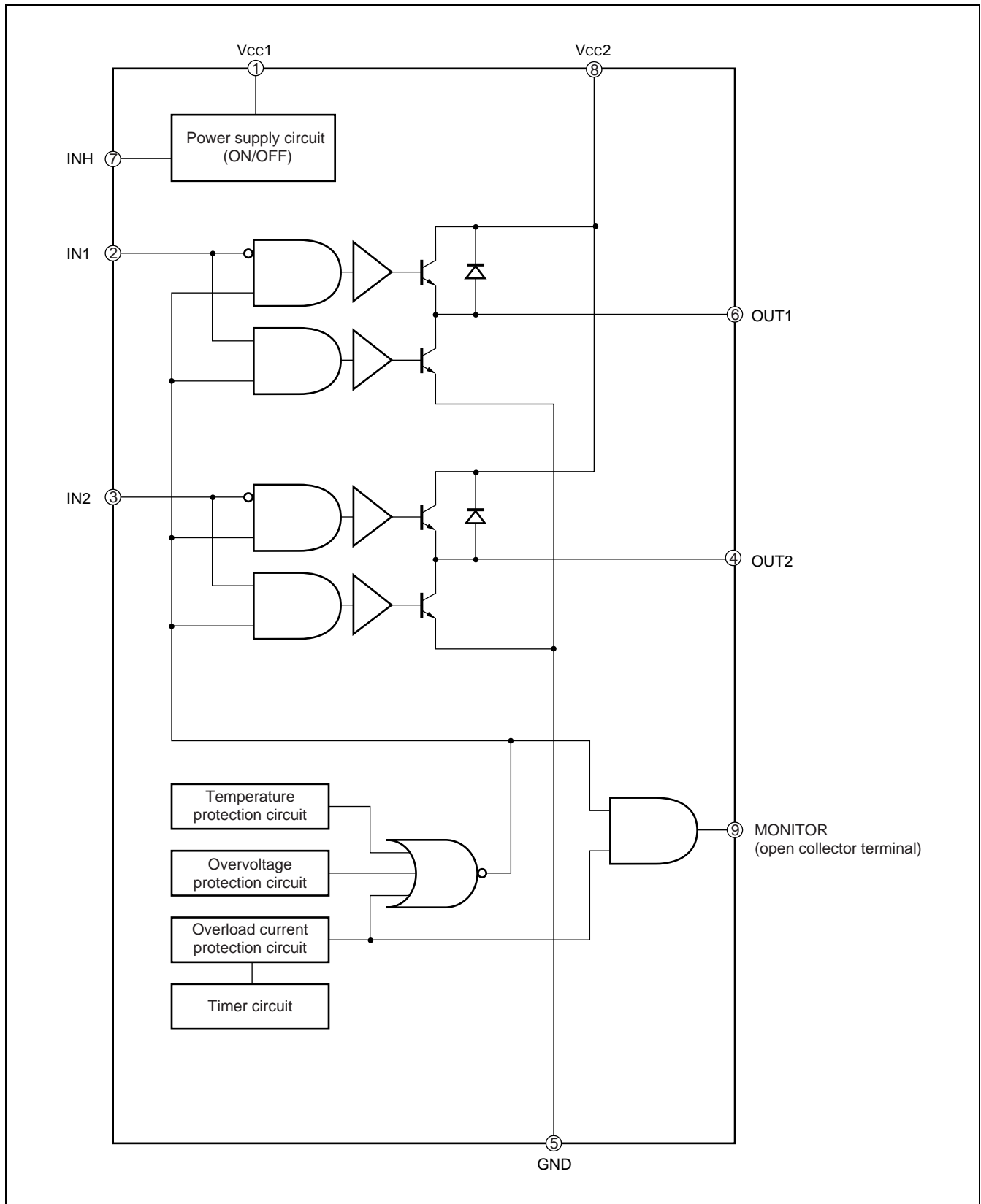

MB3853

FUNCTIONAL DESCRIPTION

The MB3853 provides two methods for controlling motors. The IC can be connected to two motors and drive each motor independently, or connected to one motor in an H-type connection and drive the motor in forward and reverse directions.

1. Sample connection to 2 motors for run-stop control.

(1) Connection diagram

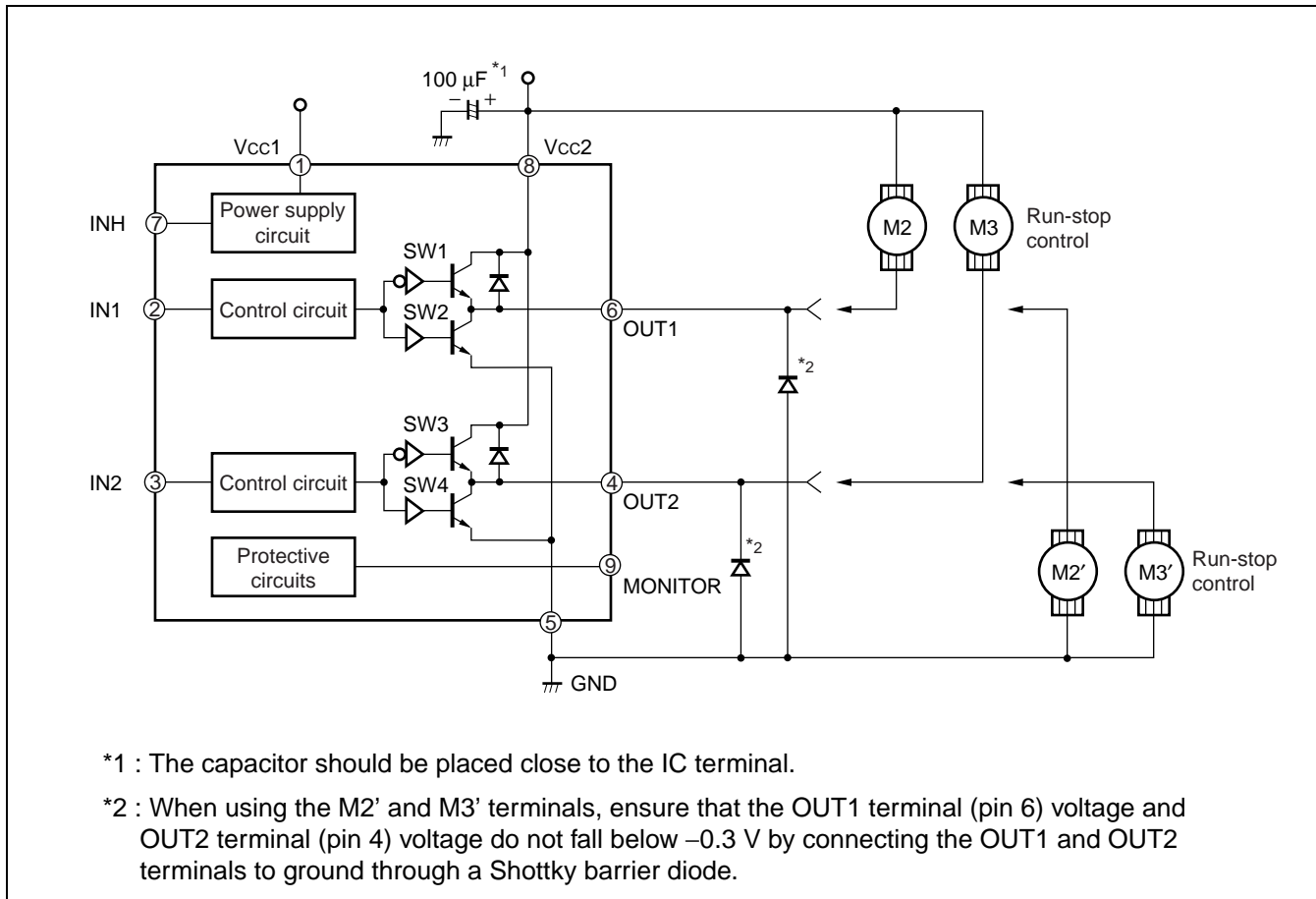

(2) Table of Functions

Mode	Input voltage level			Output terminals		Motor operating mode			
	INH	IN1	IN2	OUT1	OUT2	M2	M3	M2'	M3'
Inhibit mode	"L"	×	×	OFF (high impedance)		Continuous operation			
Mode (1)	"H"	"L"	"L"	"H"	"H"	Brake	Brake	Run	Run
Mode (2)		"L"	"H"	"H"	"L"	Brake	Run	Run	Brake
Mode (3)		"H"	"L"	"L"	"H"	Run	Brake	Brake	Run
Mode (4)		"H"	"H"	"L"	"L"	Run	Run	Brake	Brake

× : May be either "H" or "L" level

2. Sample connection to 1 motor for forward-reverse control

(1) Connection diagram

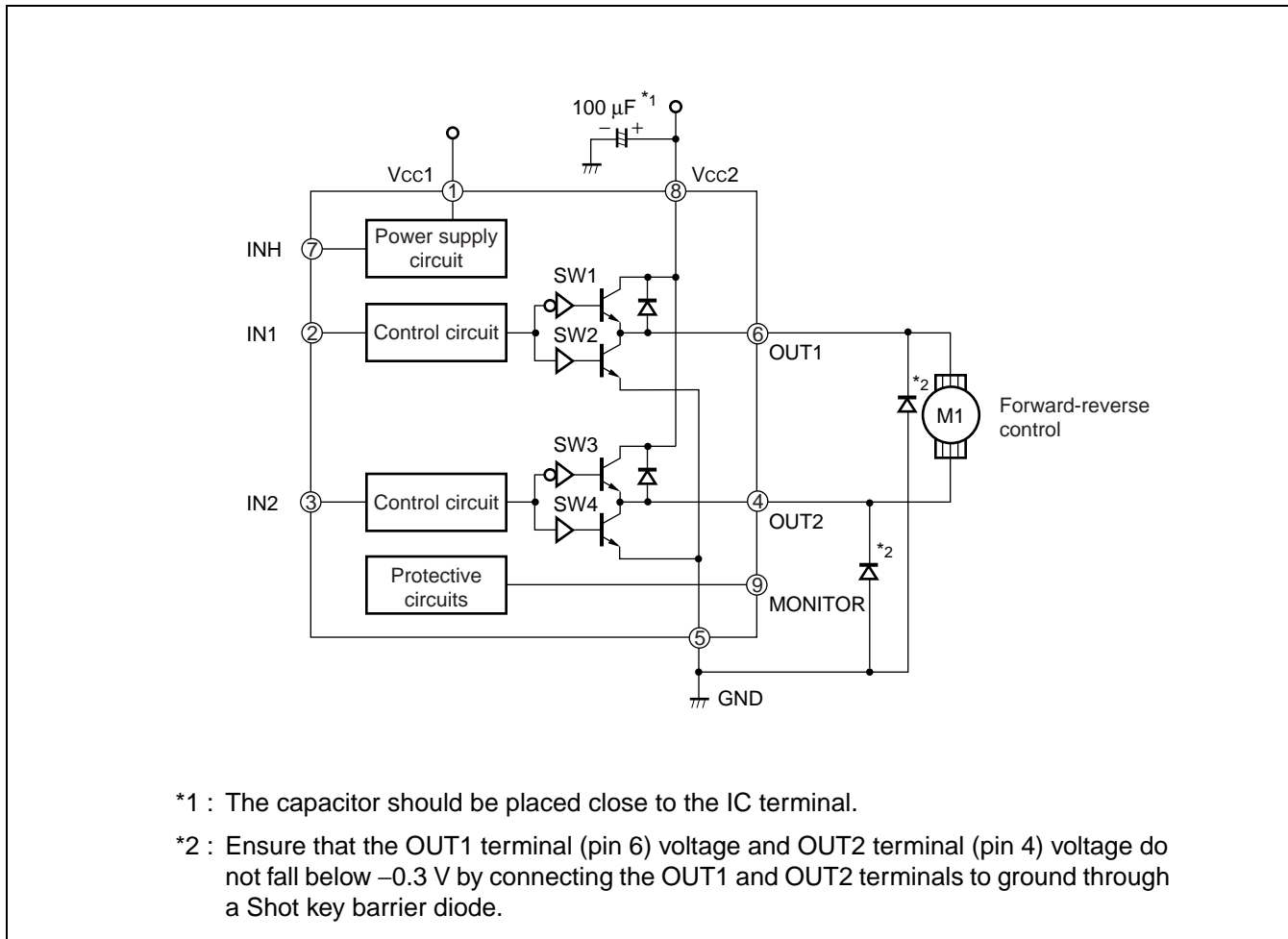

(2) Table of functions

Mode	Input voltage level			Output terminals		Motor mode
	INH	IN1	IN2	OUT1	OUT2	
Inhibit mode	"L"	×	×	OFF (High impedance)		Continuous operation
Mode (1)	"H"	"L"	"L"	"H"	"H"	Brake
Mode (2)		"L"	"H"	"H"	"L"	Forward (reverse)
Mode (3)		"H"	"L"	"L"	"H"	Reverse (forward)
Mode (4)		"H"	"H"	"L"	"L"	Brake

× : May be either "H" or "L" level

■ PROTECTIVE CIRCUITS

Circuit name	Operating description	Timing chart
<p>Overvoltage protection circuit</p>	<p>When the Vcc2 supply voltage input exceeds 33 V (Typ.) , the following occurs :</p> <ol style="list-style-type: none"> (1) All output transistors are turned off, and output is set to high impedance (2) As long as the condition is detected, the monitoring output from the open collector terminal is set to "L" level. 	
<p>Temperature protection circuit</p>	<p>When the chip temperature exceeds $T_J = +180\text{ }^\circ\text{C}$, the following occurs :</p> <ol style="list-style-type: none"> (1) All output transistors are turned off, and output is set to high impedance (2) As long as the condition is detected, the monitoring output from the open collector terminal is set to "L" level. 	
<p>Overcurrent protection circuit</p>	<p>Monitors VBE of all output transistors. When any transistor output load current exceeds $I_o = 2.4\text{ A}$ (Typ.) , the following occurs :</p> <ol style="list-style-type: none"> (1) All output transistors are switched on and off repeatedly (2) As long as the condition is detected, the monitoring output from the open collector terminal is set to "L" level. 	

* : All output transistors are turned off regardless of logic input voltage.

■ ABSOLUTE MAXIMUM RATINGS

(GND = 0 V)

Parameter	Symbol	Condition	Rating		Unit
			Min.	Max.	
Supply voltage	V _{CC1}	—	—	30	V
	V _{CC2}	—	—	30	V
Surge voltage	V _{CC(S)}	t _r ≥ 1 ms, t _s ≤ 200 ms	—	60	V
Output current	I _O	10 ms or less per terminal	—	1.8	A
Power consumption	P _D	T _C ≤ +75 °C	—	18	W
Operating temperature	T _C	—	-40	+85	°C
Storage temperature	T _{stg}	—	-55	+150	°C

WARNING: Semiconductor devices can be permanently damaged by application of stress (voltage, current, temperature, etc.) in excess of absolute maximum ratings. Do not exceed these ratings.

■ RECOMMENDED OPERATING CONDITIONS

(GND = 0 V)

Parameter	Symbol	Conditions	Values			Unit
			Min.	Typ.	Max.	
Supply voltage	V _{CC1}	Control system supply voltage	4.5	5	30	V
	V _{CC2}	Output system supply voltage	—	24	30	V
"H" level input voltage	V _{IH}	IN1, IN2, INH terminals	2.0	—	V _{CC1} + 0.3	V
"L" level input voltage	V _{IL}		-0.3	—	0.8	V
Operating temperature	T _C	—	0	25	70	°C

WARNING: The recommended operating conditions are required in order to ensure the normal operation of the semiconductor device. All of the device's electrical characteristics are warranted when the device is operated within these ranges.

Always use semiconductor devices within their recommended operating condition ranges. Operation outside these ranges may adversely affect reliability and could result in device failure.

No warranty is made with respect to uses, operating conditions, or combinations not represented on the data sheet. Users considering application outside the listed conditions are advised to contact their FUJITSU representatives beforehand.

■ ELECTRICAL CHARACTERISTICS

($T_c = +25\text{ }^\circ\text{C}$, $\text{GND} = 0\text{ V}$, $V_{cc1} = 5\text{ V}$, $V_{cc2} = 24\text{ V}$)

Parameter	Symbol	Conditions	Values			Unit
			Min.	Typ.	Max.	
"L" level input current	I_{IL}	$V_{IL} = 0.4\text{ V}$	—	—	100	μA
"H" level input current	I_{IH}	$V_{IH} = 2.4\text{ V}$	—	—	100	μA
"L" level output current	V_{OL}	$I_o = 1\text{ A}$	—	1.0	1.4	V
"H" level output current	V_{OH}	$I_o = -1\text{ A}$	22.5	23.0	—	V
Diode forward voltage	V_F	$I_o = 1.8\text{ A}$	—	2.2	—	V
Overcurrent detection current	I_{CS}	—	1.8	2.4	3.5	A
Overcurrent detection voltage	V_{SD}	—	30.5	33.0	35.5	V
"L" level monitoring output voltage	V_{OL}	$I_o = 1\text{ mA}$	—	0.2	0.4	V
"H" level monitoring output current	I_{OH}	$V_{OH} = 24\text{ V}$	—	—	0.01	mA
Supply current	I_{cc1}	IN1 = IN2 = "H"	—	3.7	7.4	mA
		IN1/IN2 = "H/L"	—	2.8	5.6	mA
		IN1 = IN2 = "L"	—	1.9	3.8	mA
	I_{cc2}	IN1 = IN2 = "H"	—	—	1.0	mA
		IN1/IN2 = "H/L"	—	13	20	mA
		IN1 = IN2 = "L"	—	26	40	mA
I_{cc0}	$I_{cc1} + I_{cc2}$ INH = "L"	—	—	1.0	mA	
Package thermal resistance	θ_{J-C}	Infinite heat dissipation	—	4	—	$^\circ\text{C/W}$
Power consumption	OUT1 or OUT2, per terminal	$I_o = 1\text{ A}$	—	1.2	—	W
		$I_o = 0\text{ mA}$ (braking)	—	300	—	mW
	In H-type drive configuration	$I_o = 1\text{ A}$	—	2.4	—	W

TYPICAL CHARACTERISTIC

Supply current vs. inhibitor terminal input voltage

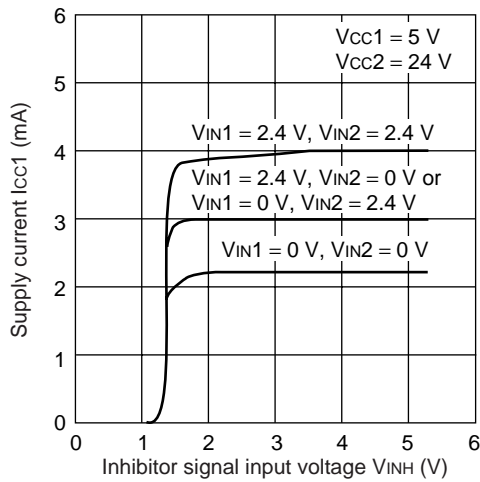

Supply voltage vs. supply current ($V_{CC1} - I_{CC1}$)

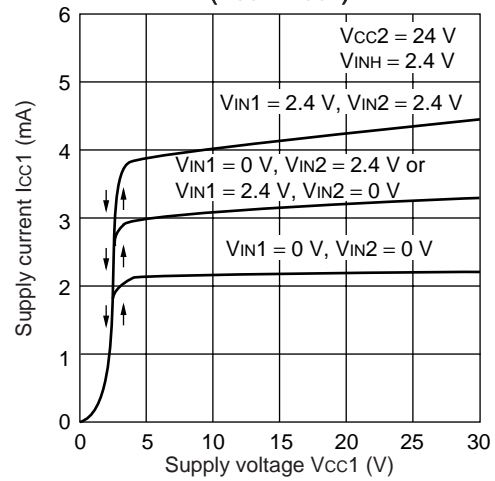

Supply voltage vs. supply current ($V_{CC2} - I_{CC1}$)

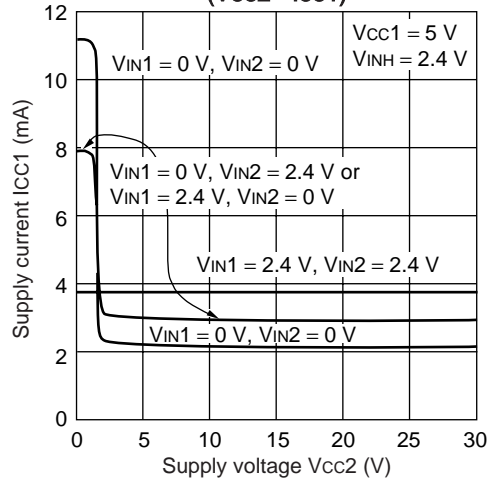

Supply voltage vs. supply current ($V_{CC2} - I_{CC2}$)

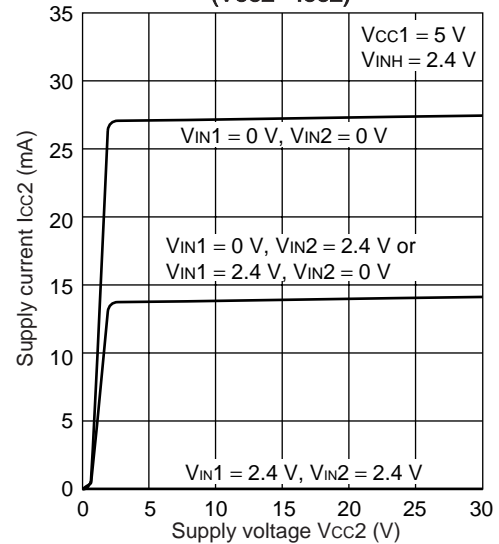

(Continued)

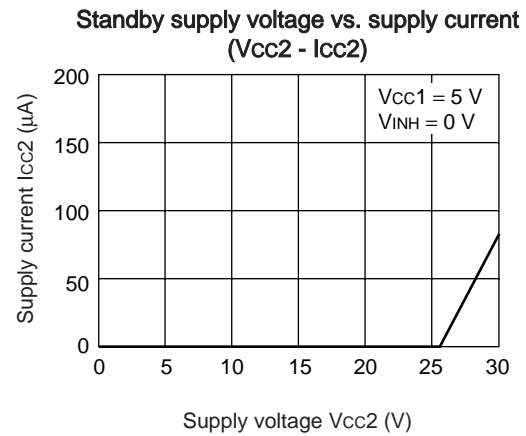
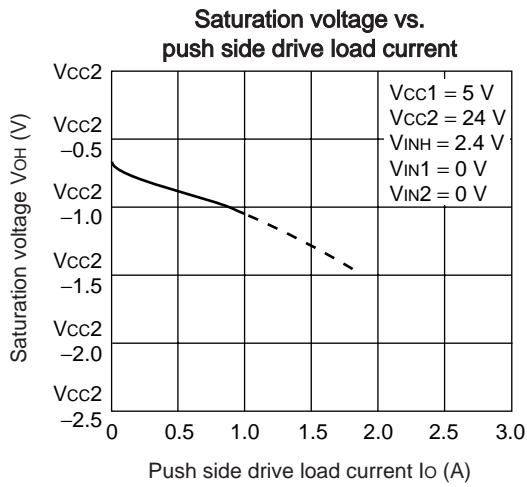
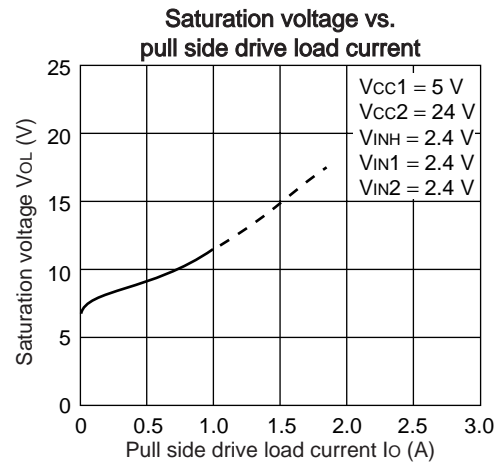
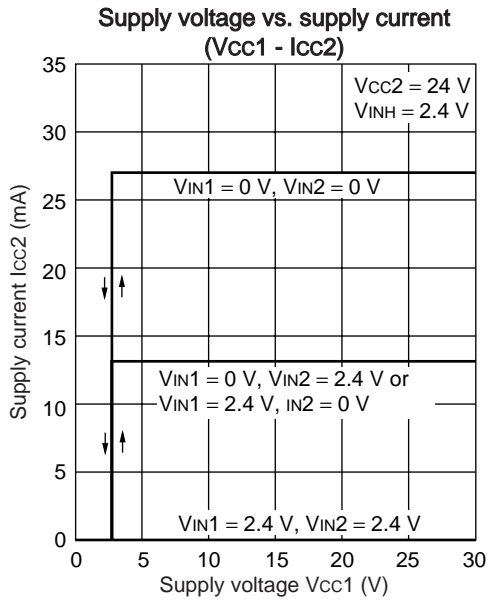

(Continued)

Monitoring terminal output current vs. output voltage

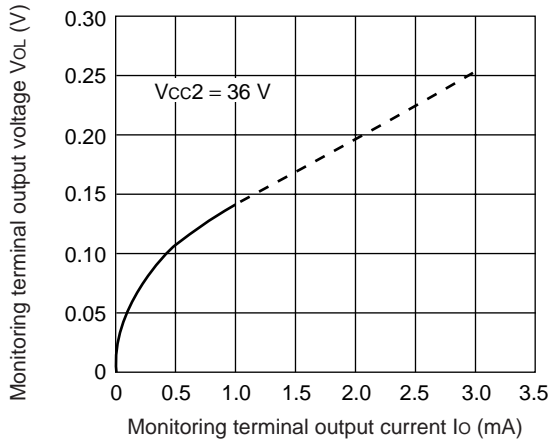

Flyback diode voltage vs. reverse surge current

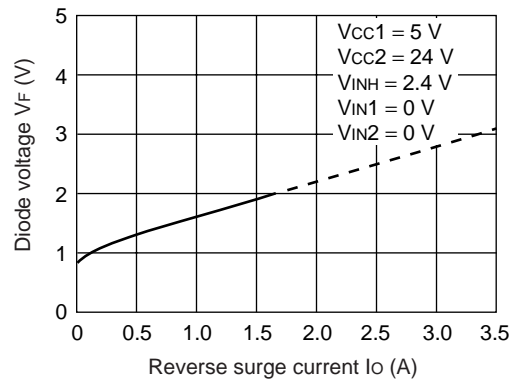

**Input current vs. input voltage
(Inhibitor terminal, function input terminals)**

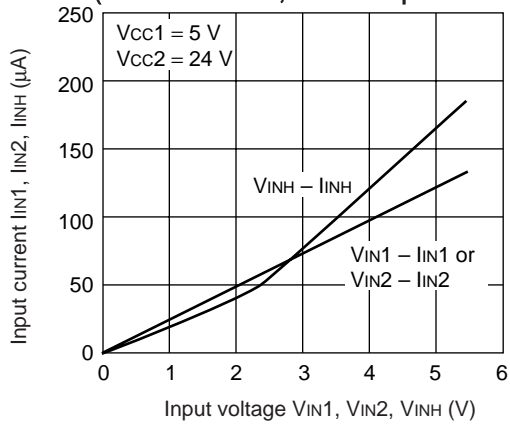

**Input current vs. voltage characteristics
at maximum applied voltage
(Inhibitor terminal, function input terminals)**

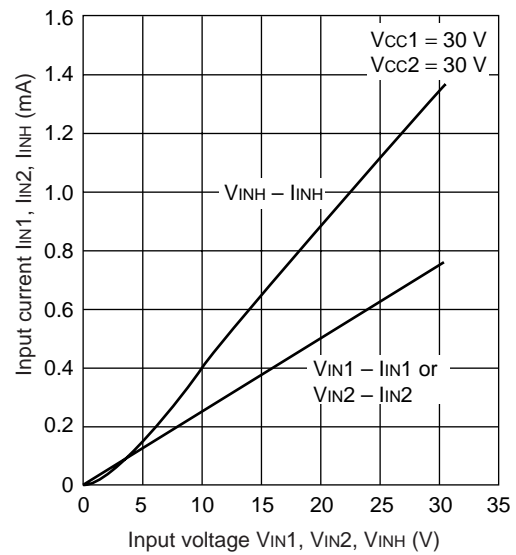

(Continued)

(Continued)

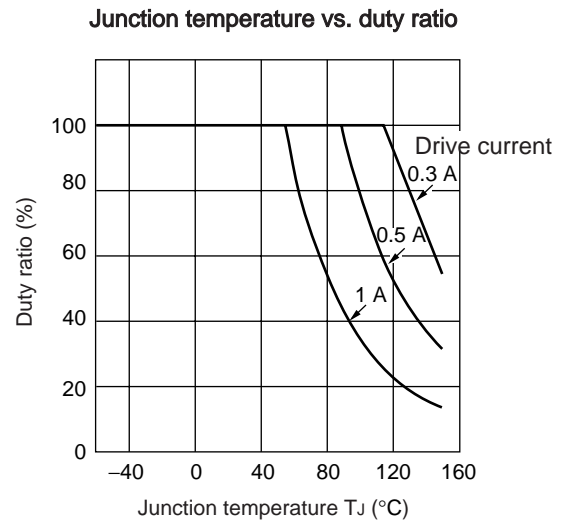
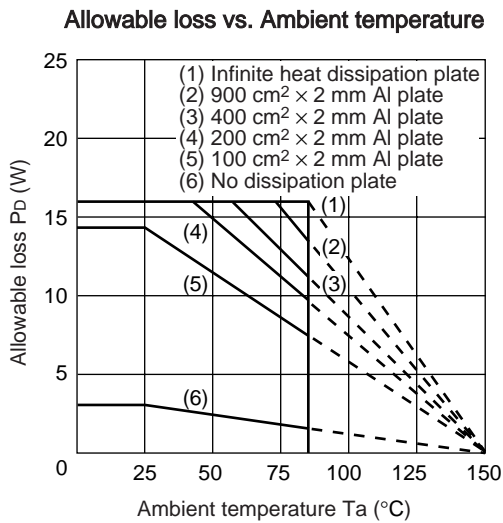

Notes : • For stable operation over periods of extended usage, the duty ratio should be kept below the characteristic curve.

• Junction temperature should be maintained at $T_J \leq +150\text{ }^\circ\text{C}$.

(T_J calculation)

$$T_J = T_C + \Delta T$$

$$\Delta T = 4\text{ (}^\circ\text{C/W)} \times P_{DI}$$

$$P_{DI} = V_{CC} \times I_{CC} + \Delta V_O \times I_O$$

$$\Delta V_O = (V_{CC} - V_{OH}) + V_{OL}$$

T_C : case temperature, ΔT : difference between case and junction temperature

P_{DI} : IC power consumption (W)

■ ORDERING INFORMATION

Part Number	Package	Remarks
MB3853PS	Plastic SIP, 9 pins (SIP-9P-M02)	

FUJITSU LIMITED

All Rights Reserved.

The contents of this document are subject to change without notice. Customers are advised to consult with FUJITSU sales representatives before ordering.

The information and circuit diagrams in this document are presented as examples of semiconductor device applications, and are not intended to be incorporated in devices for actual use. Also, FUJITSU is unable to assume responsibility for infringement of any patent rights or other rights of third parties arising from the use of this information or circuit diagrams.

The products described in this document are designed, developed and manufactured as contemplated for general use, including without limitation, ordinary industrial use, general office use, personal use, and household use, but are not designed, developed and manufactured as contemplated (1) for use accompanying fatal risks or dangers that, unless extremely high safety is secured, could have a serious effect to the public, and could lead directly to death, personal injury, severe physical damage or other loss (i.e., nuclear reaction control in nuclear facility, aircraft flight control, air traffic control, mass transport control, medical life support system, missile launch control in weapon system), or (2) for use requiring extremely high reliability (i.e., submersible repeater and artificial satellite).

Please note that Fujitsu will not be liable against you and/or any third party for any claims or damages arising in connection with above-mentioned uses of the products.

Any semiconductor devices have an inherent chance of failure. You must protect against injury, damage or loss from such failures by incorporating safety design measures into your facility and equipment such as redundancy, fire protection, and prevention of over-current levels and other abnormal operating conditions.

If any products described in this document represent goods or technologies subject to certain restrictions on export under the Foreign Exchange and Foreign Trade Law of Japan, the prior authorization by Japanese government will be required for export of those products from Japan.