

- Optimized for Texas Instrument's TMS38054 •
- Supports both UTP and STP Transmission •
- Overvoltage Protection Circuit •
- Complies with or exceeds IEEE 802.5 Requirements •

### Electrical Parameters @ 25° C

Impedance ( $\Omega$ ) [Xmit/Rcv]	Insertion Loss (dB Max.)								Return Loss (dB Min.)						Common Mode Rejection (dB Min.)						Crosstalk (dB Min.)				
	1-16 MHz		32 MHz		36 MHz		44 MHz		1-6 MHz		6-17 MHz		17-25 MHz		1-30 MHz		30-100 MHz		100 MHz			200-300 MHz		1-30 MHz	
<b>Chip Side</b> 600/150																									
<b>Cable Side</b>	Xmit	Rcv	Xmit	Rcv	Xmit	Rcv	Xmit	Rcv	Xmit	Rcv	Xmit	Rcv	Xmit	Rcv	Xmit	Rcv	Xmit	Rcv	Xmit	Rcv	Xmit	Rcv	Xmit	Rcv	
150/100	-8	-8	-7	-1	-25	-1	-35	-1	-15	-20	-15	-20	-10	-15	-70	-70	-35	-30	-45	-45	-20	-20		-35	

### Schematic

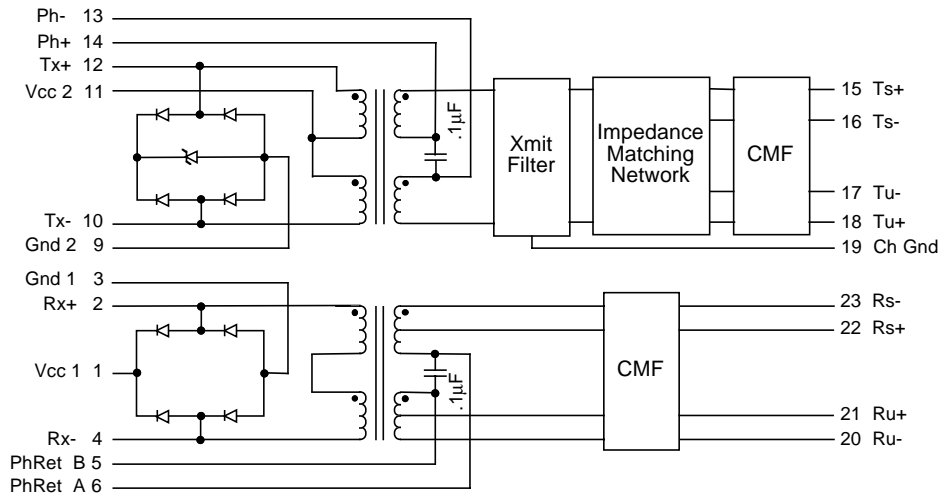

### Package

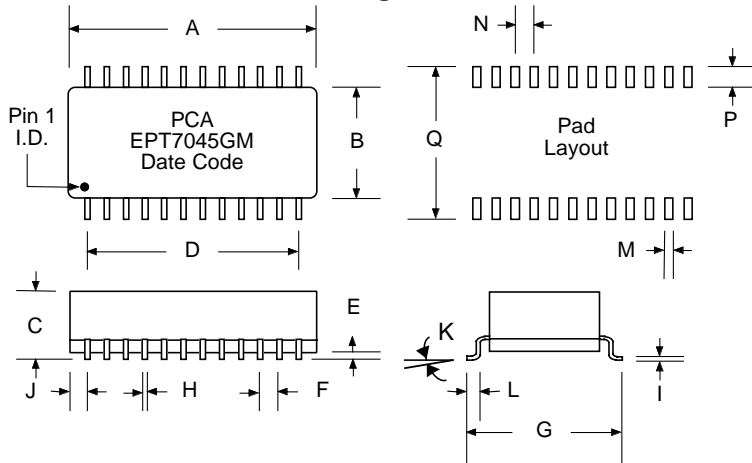

### Dimensions

Dim.	(Inches)			(Millimeters)		
	Min.	Max.	Nom.	Min.	Max.	Nom.
A	1.290	1.310		32.77	33.27	
B	.575	.585		14.60	14.86	
C	.300	.320		7.62	8.13	
D	1.110	Typ.		28.19	Typ.	
E	.003	.020		0.076	.508	
F	.100	Typ.		2.54	Typ.	
G	.780	.800		19.81	20.32	
H	.015	.021		.381	.533	
I	.008	.012		.203	.305	
J	.090	Typ.		2.28	Typ.	
K	0°	8°		0°	8°	
L	.025	.045		.635	1.14	
M			.030			.762
N			.100			2.54
P			.092			2.34
Q			.800			20.32

The circuit below is a guideline for interconnecting PCA's EPT7045GM with a typical Token Ring PHY chip for 4 Mb/16Mb applications over STP or UTP cable. Further details of system design should be obtained from the specific chip manufacturer. Note that this module is optimized for a "current source" driver such as TMS38054. Only one type of cable should be driven by the module: either UTP or STP. If you are using 120Ω cable or desire to install only one RJ45 connector thus leaving the STP use with a dongle when needed, please refer to PCA part number EPT7066 or similar parts optimized for 120Ω cable.

Note that there is no need for the receiver side filtering. So consider this a cost effective solution for almost all Token Ring applications using this chip or similar chips.

The pull down resistors to chassis via a cap shown around the RJ45 connector have been known to suppress unwanted radiation that unused wires pick up from the immediate environment. This is specially true if driving UTP cable. Their placement and use are to be considered carefully before a design is finalized.

No specific recommendation is made here for phantom return circuitry: implementation varies. Please note that additional emission control has been observed if both nodes of the phantom bypass capacitor on the transmit channel are pulled to the chassis ground via suitable capacitors.

It is recommended that there be a neat separation of ground planes in the layout. It is generally accepted practice to limit the plane off at least 0.05 inches away from the chip side pins of EPT7045GM. There need not be any ground plane beyond this point.

For best results, PCB designer should design the outgoing traces preferably to be 75Ω/50Ω (STP/UTP), balanced and well coupled to achieve minimum radiation from these traces.

### Typical Application Circuit Connection to TMS38054 (or Equivalent). Only NIC side shown.

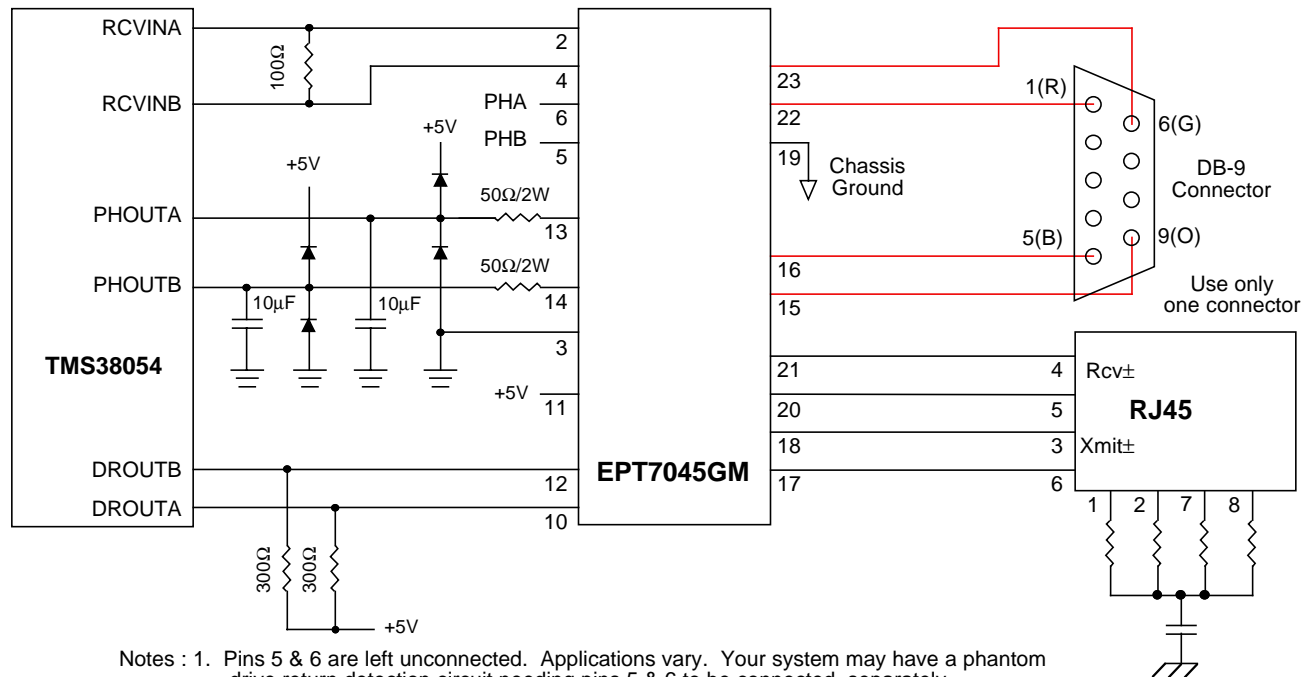

- Notes : 1. Pins 5 & 6 are left unconnected. Applications vary. Your system may have a phantom drive return detection circuit needing pins 5 & 6 to be connected separately.  
2. Red line connections to DB-9 Connector are 75Ω impedance traces.