



### Description

The ICS662-03 provides synchronous clock generation for audio sampling clock rates derived from an HDTV stream. The device uses the latest PLL technology to provide superior phase noise and long term jitter performance. The device also supports a 27 MHz output clock for video MPEG applications from an HDTV reference clock.

Please contact ICS if you have a requirement for an input and output frequency not included here.

### Features

- Packaged in 8 pin SOIC
- HDTV clock input
- Low phase noise
- Exact (0 ppm) multiplication ratios
- Support for 256 and 384 times sampling rate
- Supports 27 MHz output for video (MPEG)

### Block Diagram

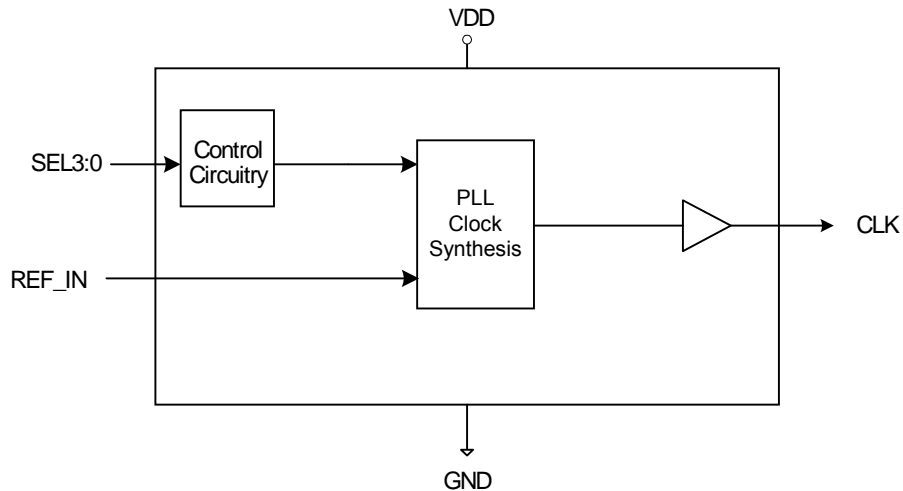



## Pin Assignment

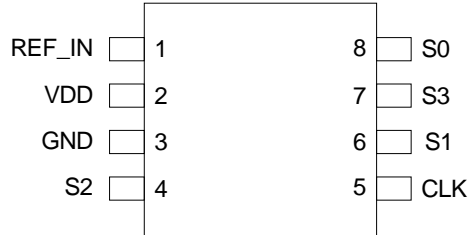

8 pin (150 mil) SOIC

## Output Clock Selection Table

S3	S2	S1	S0	Input Frequency (MHz)	Output Frequency (MHz)
0	0	0	0	74.175824	8.192
0	0	0	1	74.175824	11.2896
0	0	1	0	74.175824	12.288
0	0	1	1	74.175824	24.576
0	1	0	0	74.175824	16.9344
0	1	0	1	74.175824	18.432
0	1	1	0	74.175824	36.864
0	1	1	1	74.175824	27
1	0	0	0	74.25	8.192
1	0	0	1	74.25	11.2896
1	0	1	0	74.25	12.288
1	0	1	1	74.25	24.576
1	1	0	0	74.25	16.9344
1	1	0	1	74.25	18.432
1	1	1	0	74.25	36.864
1	1	1	1	74.25	27

## Pin Descriptions

Pin Number	Pin Name	Pin Type	Pin Description
1	REF_IN	Input	Connect this pin to a HDTV clock input.
2	VDD	Power	Connect to +3.3V.
3	GND	Power	Connect to ground.
4	S2	Input	Output frequency selection. Determines output frequency per table above. On chip pull up.
5	CLK	Output	Clock output.
6	S1	Input	Output frequency selection. Determines output frequency per table above. On chip pull up.
7	S3	Input	Output frequency selection. Determines output frequency per table above. On chip pull up.
8	S0	Input	Output frequency selection. Determines output frequency per table above. On chip pull up.



## Application Information

### Series Termination Resistor

Clock output traces should use series termination. To series terminate a 50 $\Omega$  trace (a commonly used trace impedance), place a 33 $\Omega$  resistor in series with the clock line, as close to the clock output pin as possible. The nominal impedance of the clock output is 20 $\Omega$ .

### Decoupling Capacitors

As with any high performance mixed-signal IC, the ICS662-03 must be isolated from system power supply noise to perform optimally.

Decoupling capacitors of 0.01 $\mu$ F must be connected between VDD (pin 2) and the PCB ground plane (pin 3).

### PCB Layout Recommendations

For optimum device performance and lowest output phase noise, the following guidelines should be observed.

1) Each 0.01 $\mu$ F decoupling capacitor should be mounted on the component side of the board as close to the VDD pin as possible. No vias should be used between decoupling capacitor and VDD pin. The PCB trace to VDD pin should be kept as short as possible, as should the PCB trace to the ground via. Distance of the ferrite bead and bulk decoupling from the device is less critical.

2) To minimize EMI and obtain the best signal integrity, the 33 $\Omega$  series termination resistor should be placed close to the clock output.

3) An optimum layout is one with all components on the same side of the board, minimizing vias through other signal layers (the ferrite bead and bulk decoupling capacitor can be mounted on the back). Other signal traces should be routed away from the ICS662-03. This includes signal traces just underneath the device, or on layers adjacent to the ground plane layer used by the device.



## Absolute Maximum Ratings

Stresses above the ratings listed below can cause permanent damage to the ICS662-03. These ratings, which are standard values for ICS commercially rated parts, are stress ratings only. Functional operation of the device at these or any other conditions above those indicated in the operational sections of the specifications is not implied. Exposure to absolute maximum rating conditions for extended periods can affect product reliability. Electrical parameters are guaranteed only over the recommended operating temperature range.

Item	Rating
Supply Voltage, VDD	5.5V
All Inputs and Outputs	-0.5V to VDD+0.5V
Ambient Operating Temperature	0 to +70°C
Storage Temperature	-65 to +150°C
Junction Temperature	175°C
Soldering Temperature	260°C

## Recommended Operation Conditions

Parameter	Min.	Typ.	Max.	Units
Ambient Operating Temperature	0		+70	°C
Power Supply Voltage (measured in respect to GND)	+3.0		+3.6	V

## DC Electrical Characteristics

Unless stated otherwise, VDD = 3.3V ±10%, Ambient Temperature 0 to +70°C

Parameter	Symbol	Conditions	Min.	Typ.	Max.	Units
Operating Voltage	VDD		3.0	3.3	3.6	V
Supply Current	IDD	No Load, first 8 modes		25		mA
		No Load, last 8 modes		16		mA
Input High Voltage	V <sub>IH</sub>		2			V
Input Low Voltage	V <sub>IL</sub>				0.8	V
Output High Voltage	V <sub>OH</sub>	I <sub>OH</sub> = -4 mA	VDD-0.4			V
Output High Voltage	V <sub>OH</sub>	I <sub>OH</sub> = -12 mA	2.4			V
Output Low Voltage	V <sub>OL</sub>	I <sub>OL</sub> = 12 mA			0.4	V
Short Circuit Current	I <sub>OS</sub>	Each output		±50		mA
Nominal Output Impedance	Z <sub>OUT</sub>			20		Ω
Input Capacitance	C <sub>IN</sub>	input pins		7		pF
Internal pull-up resistor	R <sub>PU</sub>	S2 pin		510		kΩ
		S3, S1, S0 pins		120		kΩ



## AC Electrical Characteristics

Unless stated otherwise, VDD = 3.3V  $\pm$ 10%, Ambient Temperature 0 to +70°C

Parameter	Symbol	Conditions	Min.	Typ.	Max.	Units
Output Clock Rise Time	t <sub>OR</sub>	20% to 80%, 15 pF load		1.2	1.5	ns
Output Clock Fall Time	t <sub>OF</sub>	80% to 20%, 15 pF load		1.0	1.5	ns
Output Duty Cycle	t <sub>OD</sub>	at VDD/2, 15 pF load	45		55	%
Jitter, short term	t <sub>P-P</sub>	15 pF load		$\pm$ 75		ps
Jitter, long term		27M output, 15pF load, first 8 modes, 1000 cycles delay		900		ps
		27M output, 15pF load, last 8 modes, 1000 cycles delay		600		ps
Frequency Synthesis Error				0		ppm

## Thermal Characteristics

Parameter	Symbol	Conditions	Min.	Typ.	Max.	Units
Thermal Resistance Junction to Ambient	$\theta_{JA}$	Still air		150		°C/W
	$\theta_{JA}$	1 m/s air flow		140		°C/W
	$\theta_{JA}$	3 m/s air flow		120		°C/W
Thermal Resistance Junction to Case	$\theta_{JC}$			40		°C/W



## Package Outline and Package Dimensions (8 pin SOIC, 150 Mil. Body)

Package dimensions are kept current with JEDEC Publication No. 95

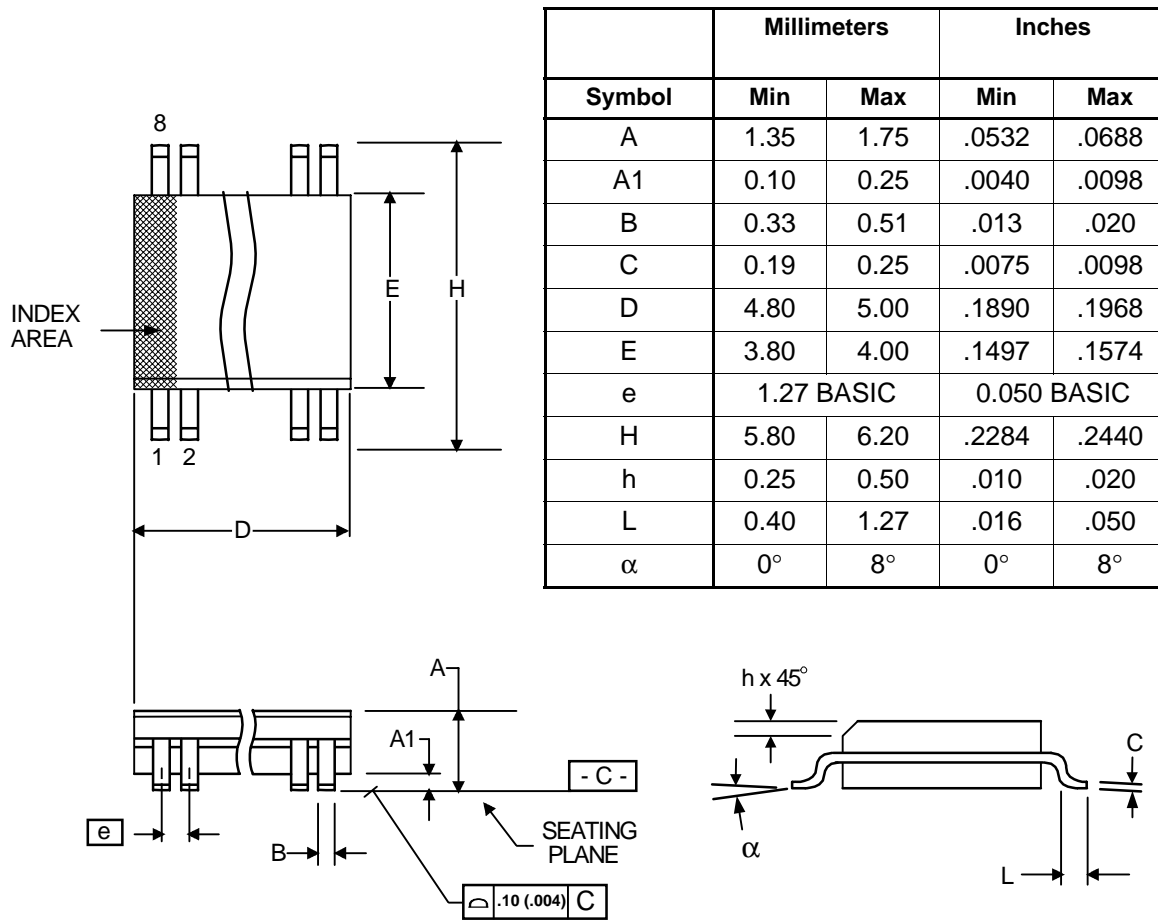

## Ordering Information

Part / Order Number	Marking	Shipping packaging	Package	Temperature
ICS662M-03	662M-03	Tubes	8 pin SOIC	0 to +70°C
ICS662M-03TR	662M-03	Tape and Reel	8 pin SOIC	0 to +70°C

While the information presented herein has been checked for both accuracy and reliability, Integrated Circuit Systems (ICS) assumes no responsibility for either its use or for the infringement of any patents or other rights of third parties, which would result from its use. No other circuits, patents, or licenses are implied. This product is intended for use in normal commercial applications. Any other applications such as those requiring extended temperature range, high reliability, or other extraordinary environmental requirements are not recommended without additional processing by ICS. ICS reserves the right to change any circuitry or specifications without notice. ICS does not authorize or warrant any ICS product for use in life support devices or critical medical instruments.