

HANTRONIX

PRODUCT SPECIFICATION

HDM3224-1

320X240 (1/4 VGA) GRAPHICS
LCD DISPLAY MODULE

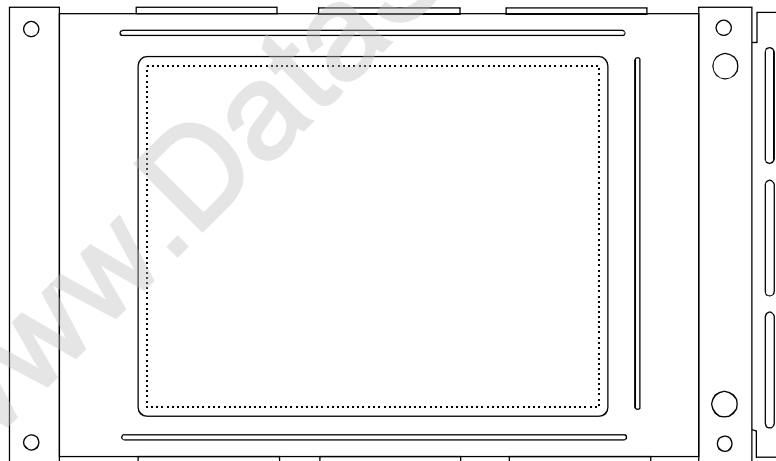

HANTRONIX, INC. 10080 BUBB RD. CUPERTINO, CA 95014	Q.A.: JK	REV.: 3.2	HDM3224-1	SHEET 1 OF 16
				DATE: 6/7/02

1. MECHANICAL DATA

(1) Product No.	HDM3224-1
(2) Module Size	167.1 (W)mm x 109.0 (H)mm x MAX 11.0 (D)mm (CCFT B.L.)
(3) Dot Size	0.33 (W)mm x 0.33 (H)mm
(4) Dot Pitch	0.36 (W)mm x 0.36 (H)mm
(5) Number of Dots	320 (W) x 240 (H)Dots
(6) Duty	1/240
(7) LCD Display Mode	FSTN: Black and White(Normally Black) Rear Polarizer: Transmissive
(8) Viewing Direction	6 O'clock
(9) Backlight	CCFT
(10) Recommended CCFL Inverter	TDK CORP. CXA-L10L
(11) Weight	198 g(approx.)

HANTRONIX, INC. 10080 BUBB RD. CUPERTINO, CA 95014	Q.A.: JK	REV.: 3.2	HDM3224-1	SHEET 2 OF 16
				DATE: 6/7/02

2. ABSOLUTE MAXIMUM RATINGS

(1) ELECTRICAL ABSOLUTE RATINGS

VSS=0V STANDARD

ITEM	SYMBOL	MIN	MAX	UNIT	COMMENT
Power Supply for Logic	VDD-VSS	-0.3	7.0	V	
Power Supply for LCM	VDD-VEE	0	30.0	V	
Input Voltage	VI	-0.3	VDD	V	
CCFL Driving Voltage	VFL	0	500	Vrms	
CCFL Input Current	IFL	-	7.0	mA rms	
Static Electricity	-	-	-	-	Note 1

(2) ENVIRONMENTAL ABSOLUTE MAXIMUM RATINGS

ITEM	OPERATING		STORAGE	
	MIN.	MAX.	MIN.	MAX.
Ambient Temperature	-20	70	-30	80
Humidity(Without Condensation)	Note 2,4		Note 3,4	

Note 1 LCM should be grounded during handling LCM.

Note 2 $T_a \leq 70^\circ\text{C}$: 75%RH max

$T_a > 70^\circ\text{C}$: Absolute humidity must be lower than the humidity of 75%RH at 70°C

Note 3 T_a at -30°C will be < 48hrs, at 80°C will be < 120hrs

Note 4 Background color will change slightly depending on ambient temperature. That phenomenon is reversible.

HANTRONIX, INC. 10080 BUBB RD. CUPERTINO, CA 95014	Q.A.:	REV.:	HDM3224-1	SHEET 3 OF 16
	JK	3.2		DATE: 6/7/02

3. ELECTRICAL CHARACTERISTICS

(VDD = 5V±5%)

ITEM	SYMBOL	CONDITION	MIN.	TYP.	MAX.	UNIT	
Power Supply for Logic	VDD-VSS	-	4.75	5.0	5.25	V	
Recommended LC Driving Voltage (High Contrast Ratio LC LCM)	VDD-VO	Duty=1/240 Bias=1/13	-20°C	-	25.0	25.4	V
			0°C	-	23.6	24.0	
			25°C	-	22.9	23.3	
			50°C	-	21.5	21.9	
			70°C	-	20.9	21.3	
Input Voltage	V _{IH}	H level	0.8VDD	-	VDD	V	
	V _{IL}	L level	0	-	0.2VDD	V	
Power Supply Current	I _{DD}	FLM = 70 Hz VDD = 5.0 V VEE = -24.0 V VDD-VO = 22.9 V	-	4.7	10.0	mA	
	I _{EE}	PATTERN : 	-	4.2	8.0	mA	
CCFL LAMP	Starting Voltage	V _s	-	450	1000	V _{rms}	
	Lamp Voltage	V _L	-	260	-	V _{rms}	
	Lamp Current	I _L	4	5	6	mArms	
	Lamp Consumption	P _L	-	1.3	-	W	
	Lamp Frequency	F _L	-	35	-	KHz	
	Lamp Life	L _L	-	20000	-	hr	
LCM	Surface Luminance	L	ALL ON	-	154.2	-	cd/m ²
		L	ALL OFF	-	7.8	-	

HANTRONIX, INC. 10080 BUBB RD. CUPERTINO, CA 95014	Q.A.:	REV.:	HDM3224-1	SHEET 4 OF 16
	JK	3.2		DATE: 6/7/02

4.OPTICAL CHARACTERISTICS

AT V_{OP}

ITEM MODE		Cr(Contrast Ratio)										θ(Viewing Angle)		θ(Viewing Angle)	
		-20℃		0℃		25℃		50℃		70℃		25℃		25℃	
		MIN.	TYP.	MIN.	TYP.	MIN.	TYP.	MIN.	TYP.	MIN.	TYP.	MIN.	TYP.	MIN.	TYP.
T	G	-	-	-	8.0	-	8.0	-	6.5	-	-	-	76	-	±62
note		NOTE6										NOTE5			

note: T : TRANSMISSIVE

G : NORMALLY BLACK

AT φ=0° θ=0°

ITEM	SYMBOL	CONDITION	MIN.	TYP.	MAX.	UNIT	NOTE
Response Time (rise)	Tr	-20℃	-	3700	5500	ms	NOTE 2
		0℃	-	660	900		
		25℃	-	160	240		
		50℃	-	110	165		
		70℃	-	75	110		
Response Time (fall)	Tf	-20℃	-	2600	3900	ms	NOTE 2
		0℃	-	560	840		
		25℃	-	90	140		
		50℃	-	75	110		
		70℃	-	50	70		

HANTRONIX, INC.
10080 BUBB RD.
CUPERTINO, CA 95014

Q.A.:

JK

REV.:

3.2

HDM3224-1

SHEET 5 OF 16

DATE:

6/7/02

(NOTE 1)

Definition of Operation Voltage(Vop)

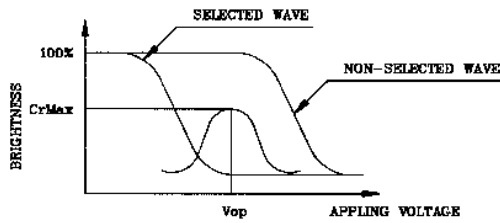

(positive type)

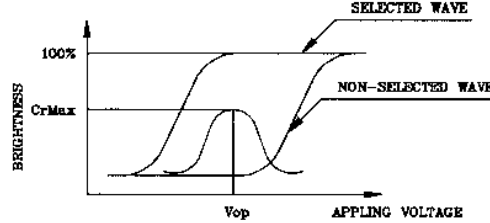

(negative type)

*Conditions

- Viewing Angle : 0
- Frame Frequency : 70Hz
- Applying Waveform : 1/N duty 1/a bias

(NOTE 2)

Definition of Response Time(Tr,Tf)

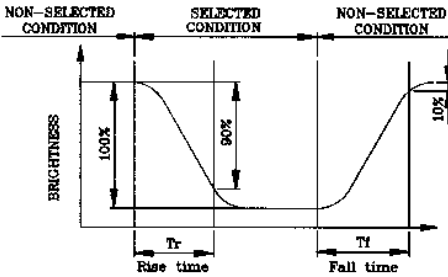

(positive type)

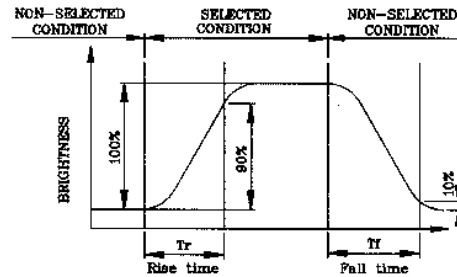

(negative type)

*Conditions

- Operating Voltage : Vop
- Viewing Angle (θ): (0,0)
- Frame Frequency : 70Hz
- Applying Waveform : 1/N duty 1/a bias

(NOTE 3)

Description of Measuring Equipment and Driving Waveforms

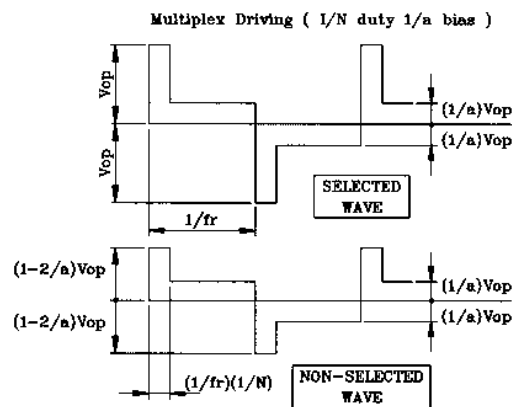
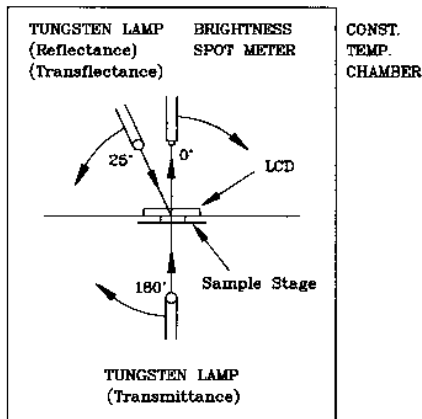

HANTRONIX, INC.
10080 BUBB RD.
CUPERTINO, CA 95014

Q.A.:
JK

REV.:
3.2

HDM3224-1

SHEET 6 OF 16

DATE:
6/7/02

(NOTE 4)

Definition of Viewing Direction

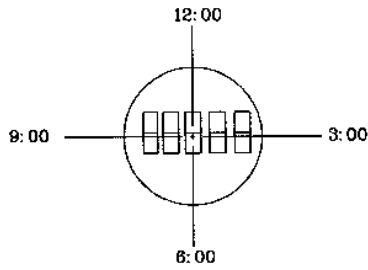

(NOTE 5)

Definition of Viewing Angle

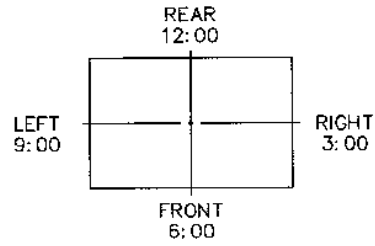
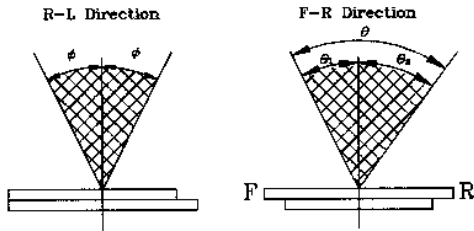

*For This Product
The Viewing Direction Is 6 O'clock
So $\theta_1 > \theta_2$

$\theta = \theta_1 + \theta_2$

*Conditions

Operating Voltage : V_{op}
Frame Frequency : 70Hz
Applying Waveform : 1/N duty 1/a bias
Contrast Ratio : larger than 2

(NOTE 6)

Definition of Contrast Ratio (Cr)

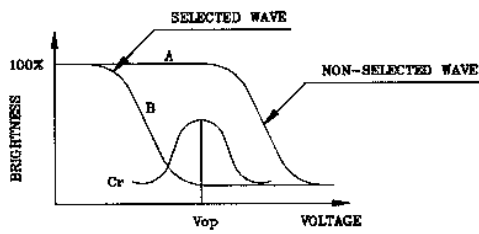

(positive type)

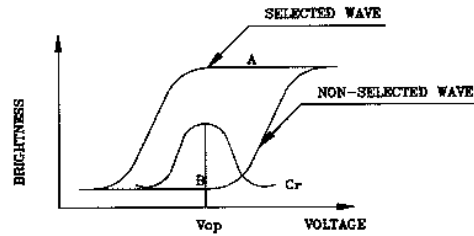

(negative type)

Contrast Ratio : $Cr = A/B$

*Conditions

Viewing Angle : 0
Frame Frequency : 70Hz
Applying Waveform : 1/N duty 1/a bias

HANTRONIX, INC.
10080 BUBB RD.
CUPERTINO, CA 95014

Q.A.:
JK

REV.:
3.2

HDM3224-1

SHEET 7 OF 16

DATE:
6/7/02

5. BLOCK DIAGRAM

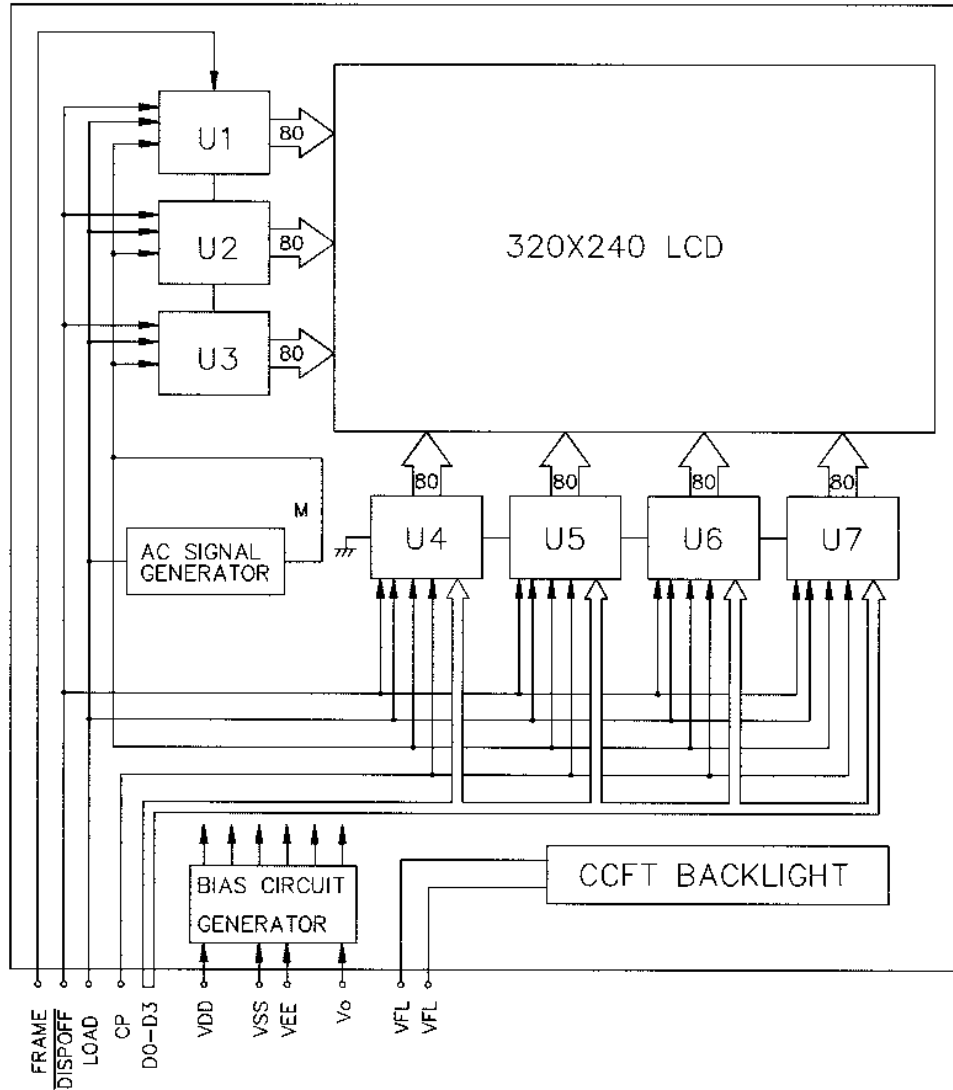

* AC SIGNAL SETTING

J1	J2	J3	J4	J5	J6	J7	J8
L	H	H	L	L	L	L	L

HANTRONIX, INC.
10080 BUBB RD.
CUPERTINO, CA 95014

Q.A.:

JK

REV.:

3.2

HDM3224-1

SHEET 8 OF 16

DATE:

6/7/02

6. INTERNAL PIN CONNECTION

CN1; CN2; CN4 :

Pin No.	Symbol	Level	Function
1	D0	H/L	Display Data Signal
2	D1		
3	D2		
4	D3		
5	Display	H/L	H: On ; L: Off
6	Frame	H	Scan Start-Up Signal
7	DF	H/L	AC Signal for LCD
8	Load	H→L	Input Data Latch Signal
9	CP	H→L	Data Input Clock Signal
10	VDD	-	Power Supply for Logic (+5V)
11	VSS	-	Signal Ground (0V)
12	VEE	-	Power Supply for LCD
13	V0	-	LCD Contrast Adjust Voltage
14	FGND	-	Front Panel Ground

CN3 :

Pin No.	Symbol	Level	Function
1	Frame	H	Scan Start-Up Signal
2	DF	H/L	AC Signal for LCD
3	Load	H→L	Input Data Latch Signal
4	CP	H→L	Data Input Clock Signal
5	Display	H/L	H: On ; L: Off
6	D0	H/L	Display Data Signal
7	D1		
8	D2		
9	D3		
10	VDD	-	Power Supply for Logic (+5V)
11	VSS	-	Signal Ground (0V)
12	VEE	-	Power Supply for LCD
13	V0	-	LCD Contrast Adjust Voltage
14	FGND	-	Front Panel Ground

CN5 :

Pin No.	Symbol	Level	Function
1	HV	-	Power Supply Voltage for CCFL
2	NC	-	No Connection
3	NC	-	No Connection
4	GND	-	Ground Line (From Inverter)

HANTRONIX, INC.
10080 BUBB RD.
CUPERTINO, CA 95014

Q.A.:

JK

REV.:

3.2

HDM3224-1

SHEET 9 OF 16

DATE:

6/7/02

7. POWER SUPPLY

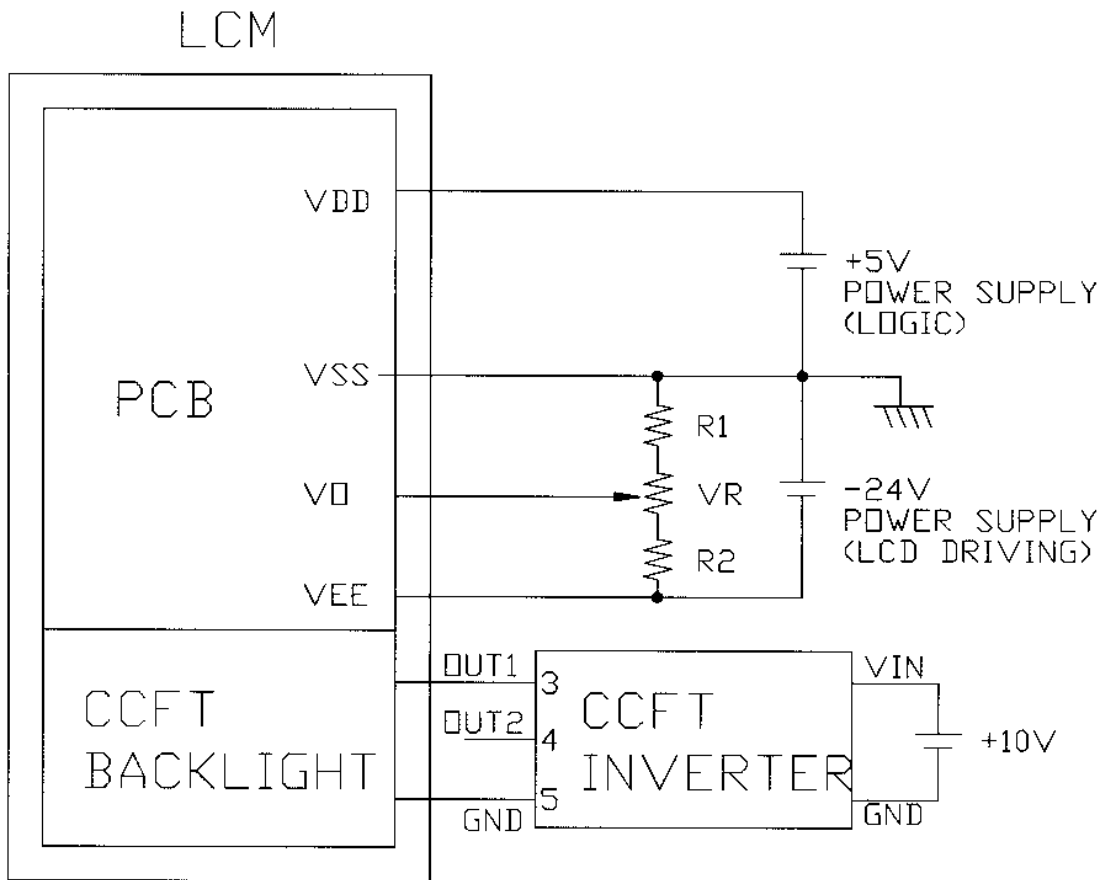

1. $R1 + VR + R2 = 10K \sim 20K \Omega$

2. RECOMMENDED CCFT INVERTER : CXA-L10L(TDK)

(OPERATING TEMP. $-10^{\circ} \sim 60^{\circ}C$)

HANTRONIX, INC.
10080 BUBB RD.
CUPERTINO, CA 95014

Q.A.:

JK

REV.:

3.2

HDM3224-1

SHEET 10 OF 16

DATE:

6/7/02

8.1 TIMING CHARACTERISTICS

ITEM	SYMBOL	MIN.	TYP.	MAX.	UNIT
CLOCK CYCLE TIME	t_{cyc}	125	—	—	ns
CLOCK HIGH LEVEL WIDTH	t_{cwh}	45	—	—	ns
CLOCK LOW LEVEL WIDTH	t_{cwl}	45	—	—	ns
CLOCK RISE TIME	t_r	—	—	30	ns
CLOCK FALL TIME	t_f	—	—	30	ns
DATA SETUP TIME	t_{ds}	30	—	—	ns
DATA HOLD TIME	t_{dh}	30	—	—	ns
CLOCK SETUP TIME	t_{scl}	80	—	—	ns
CLOCK HOLD TIME	t_{hcl}	80	—	—	ns
FRAME SETUP TIME	t_{setup}	30	—	—	ns
FRAME HOLD TIME	t_{hold}	30	—	—	ns

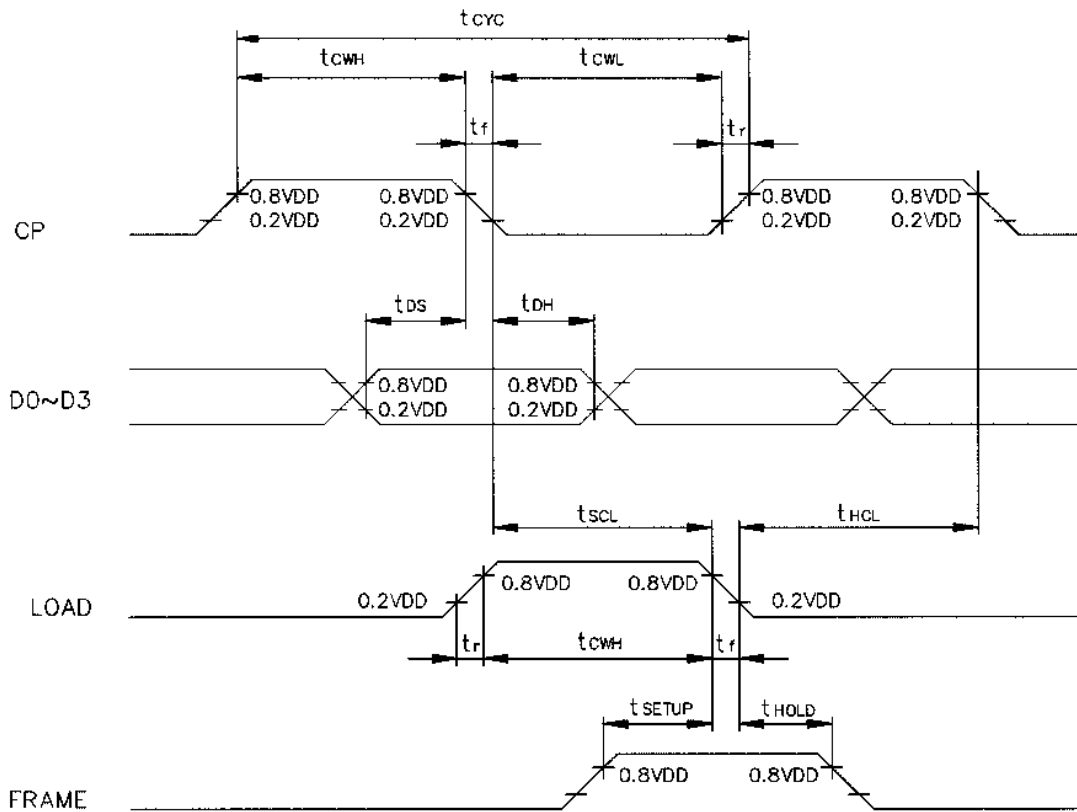

8.2 TIMING CHART OF INPUT SIGNALS

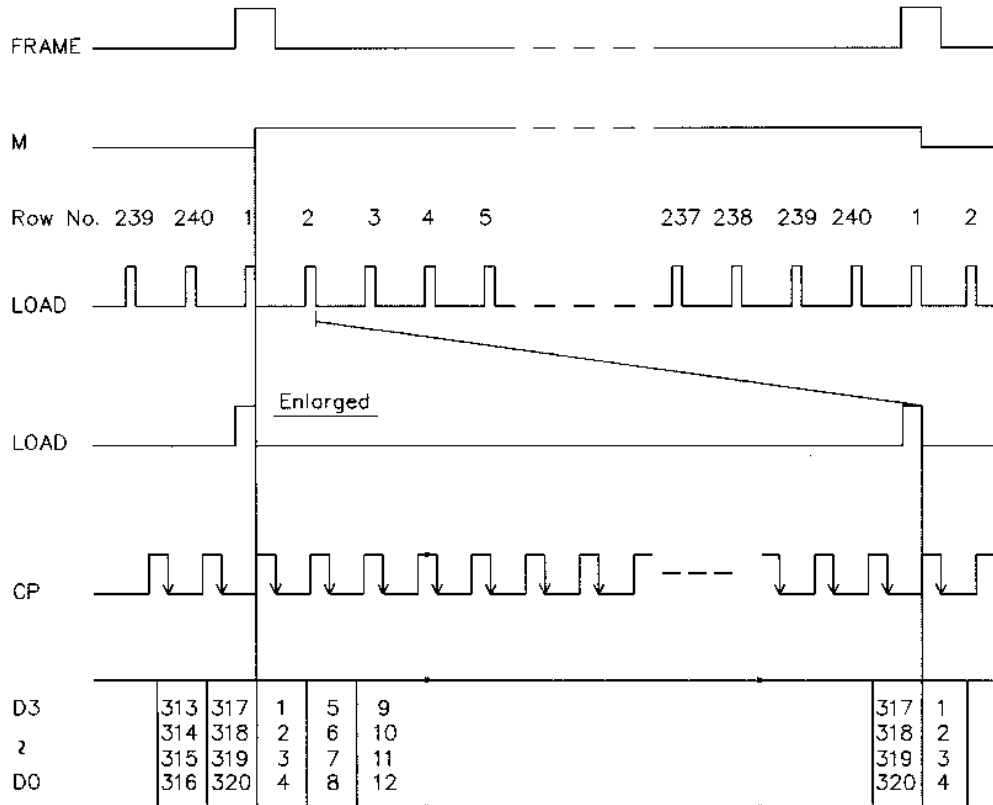

8.3 DISPLAY PATTERN

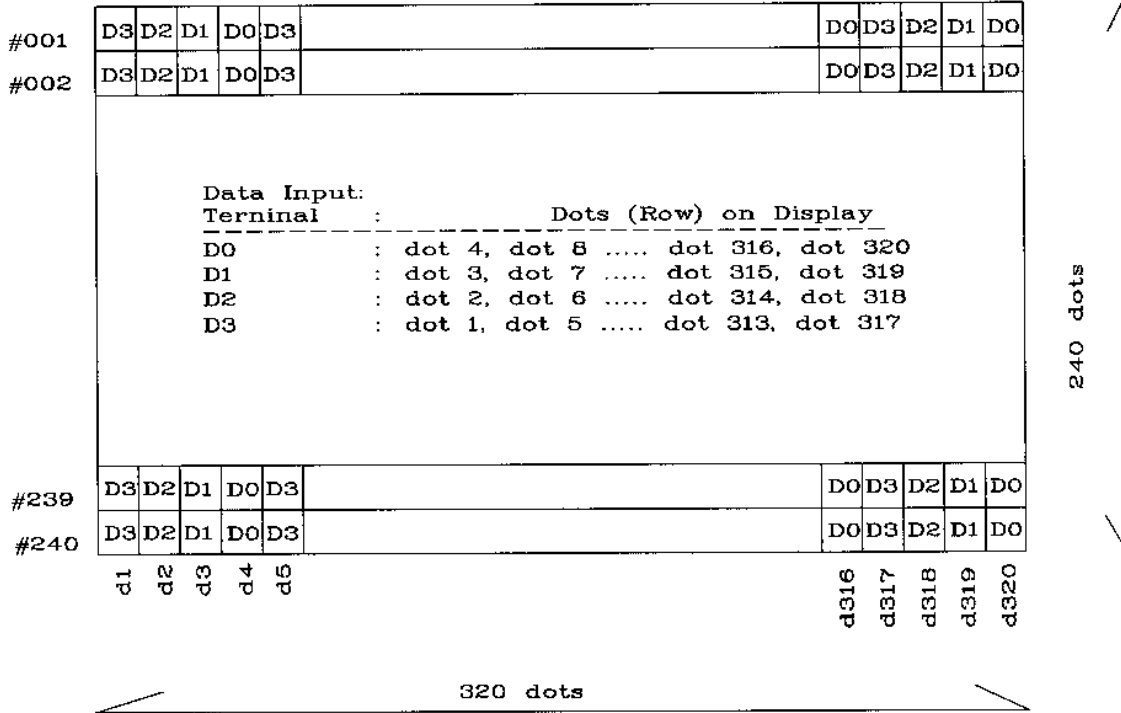

8.4 POWER ON/OFF TIMING

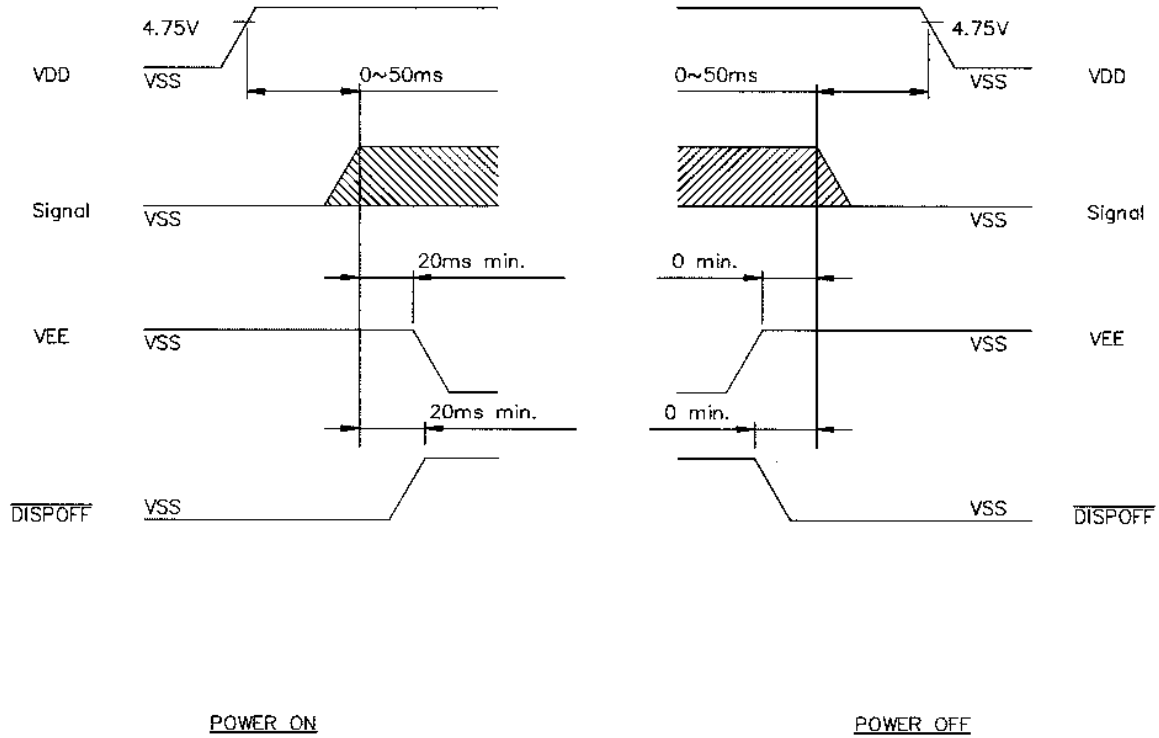

The missing pixels may occur when the LCM is driven beyond above power interface timing sequence.

HANTRONIX, INC. 10080 BUBB RD. CUPERTINO, CA 95014	Q.A.:	REV.:	HDM3224-1	SHEET 14 OF 16
	JK	3.2		DATE: 6/7/02

NOTE:

- SAFETY

- 1.If the LCD panel breaks, be careful not to get the liquid crystal to touch your skin.
- 2.If the liquid crystal touches your skin or clothes, please wash it off immediately by using soap and water.

- HANDLING

- 1.Avoid static electricity which can damage the CMOS LSI.
- 2.Do not remove the panel or frame from the module.
- 3.The polarizing plate of the display is very fragile. So, please handle it very carefully.
- 4.Do not wipe the polarizing plate with a dry cloth, as it may easily scratch the surface of plate.
- 5.Do not use ketonics solvent & Aromatic solvent, use with a soft cloth soaked with a cleaning naphtha solvent.

- STORAGE

- 1.Store the panel or module in a dark place where the temperature is $25^{\circ}\text{C}\pm 5^{\circ}\text{C}$ and the humidity is below 65% RH.
- 2.Do not place the module near organics solvents or corrosive gases.
- 3.Do not crush, shake, or jolt the module.

- TERMS OF WARRANT

- 1.Acceptance inspection period
The period is within one month after the arrival of contracted commodity at the buyer's factory site.
- 2.Applicable warrant period
The period is within twelve months since the date of shipping out under normal using and storage conditions.

HANTRONIX, INC. 10080 BUBB RD. CUPERTINO, CA 95014	Q.A.: JK	REV.: 3.2	HDM3224-1	SHEET 15 OF 16
				DATE: 6/7/02

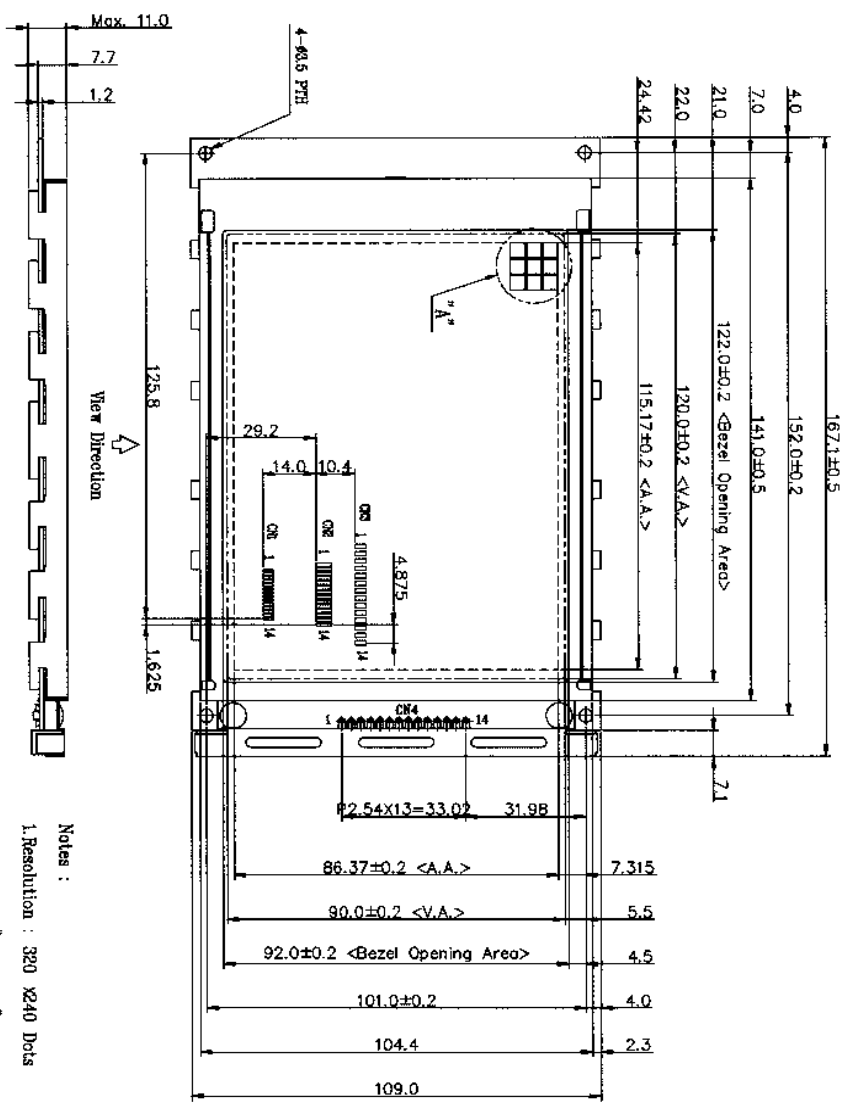

- Notes :
- 1. Resolution : 320 X240 Dots
 - 2. Driver IC: "SAMSUNG" JS30088
 - 3. Backlight : CCTFL
 - 4. Frame: SBCX (0.5 t)

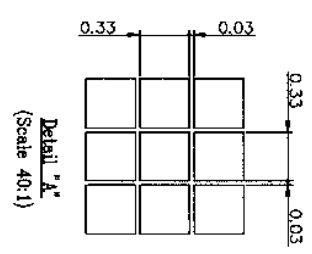
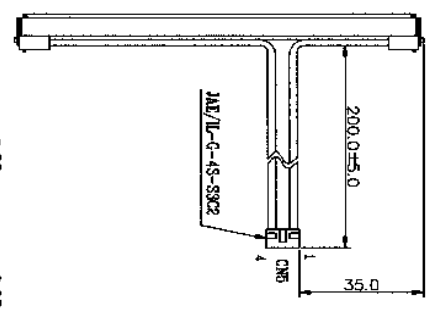

HANTRONIX, INC. 10080 BUBB RD. CUPERTINO, CA 95014	Q.A.:	REV.:	HDM3224-1	SHEET 16 OF 16
	JK	3.2		DATE: 6/7/02