

17-24GHz Low Noise Amplifier

GaAs Monolithic Microwave IC

Description

The CHA2090 is a three-stage self-biased wide band monolithic low noise amplifier.

The circuit is manufactured with a standard HEMT process : 0.25µm gate length, via holes through the substrate, air bridges and electron beam gate lithography.

It is supplied in chip form.

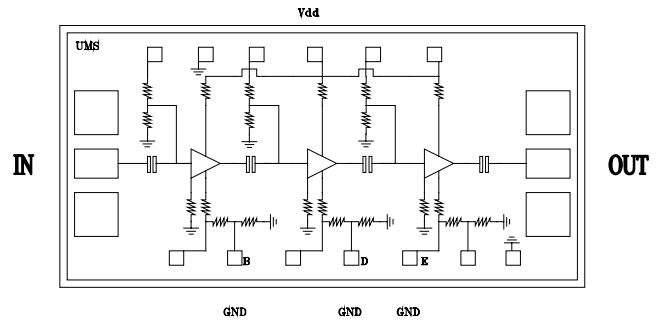

Main Features

- Broadband performance 17-24GHz
- 2.0dB noise figure
- 23dB gain, ± 1dB gain flatness
- Low DC power consumption, 55mA
- Chip size : 2,170 x 1,270x 0.1mm

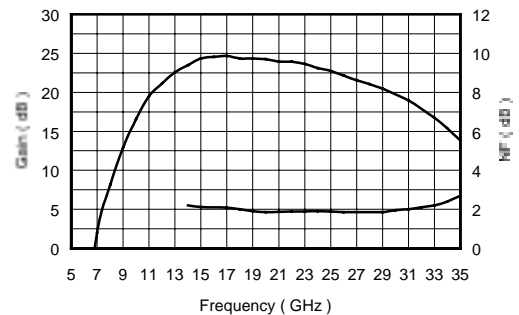

On wafer typical measurements

Main Characteristics

Tamb = +25°C, Vd=4.5V, Pads B,D,E=GND

Symbol	Parameter	Min	Typ	Max	Unit
Fop	Operating frequency range	17		24	GHz
NF	Noise figure		2.0	3.0	dB
G	Gain	19	23		dB
VSWRin	Input VSWR			2:1	
VSWRout	Output VSWR			2:1	

ESD Protection : Electrostatic discharge sensitive device. Observe handling precautions !

Main Characteristics

Tamb = +25°C, Vd=4.5V, Pads B,D,E=GND

Symbol	Parameter	Min	Typ	Max	Unit
Fop	Operating frequency range	17		24	GHz
NF	Noise figure (1)		2	3	dB
G	Gain (1)	19	23		dB
Pout	Pout -1dB gain compression		10		dBm
VSWRin	Input VSWR (1)		2.0:1	2.5:1	
VSWRout	Output VSWR (1)		2.0:1	2.5:1	
Vdd	Positive Drain voltage (2)		4.5	5.0	V

(1) These values are representative of on-wafer measurements that are made without bonding wires at the RF ports. When the chip is attached with typical 0.15nH input and output bonding wires, the indicated parameter values should be improved.

(2) See chip biasing option page 7/8.

Absolute Maximum Ratings (1)

Tamb = +25°C

Symbol	Parameter	Values	Unit
Vd	Drain bias voltage (3)	5.5	V
Pin	Maximum peak input power overdrive (2)	+15	dBm
Top	Operating temperature range	-40 to +85	°C
Tstg	Storage temperature range	-55 to +125	°C

(1) Operation of this device above anyone of these parameters may cause permanent damage.

(2) Duration < 1s.

(3) See chip biasing option page 7/8.

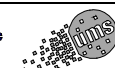

Typical Result**Chip Typical Response (On wafer Sij) :**

Tamb = +25°C VD = 4.5V ID = 55mA

Frequency	MS11 <i>mod</i>	PS11 <i>pha</i>	MS12 <i>mod</i>	PS12 <i>pha</i>	MS21 <i>mod</i>	PS21 <i>pha</i>	MS22 <i>mod</i>	PS22 <i>pha</i>
GHz	dB	deg	dB	deg	dB	deg	dB	deg
1.000	-0.53	-20.8	-89.62	-92.0	-41.76	-148.5	-0.72	-23.8
2.000	-0.06	-39.0	-97.43	26.6	-48.17	170.5	-0.30	-50.3
3.000	-0.10	-58.5	-87.21	-23.0	-52.46	74.5	-0.33	-75.6
4.000	-0.16	-77.4	-84.87	-135.7	-61.22	154.8	-0.49	-101.9
5.000	-0.23	-96.5	-83.35	120.1	-35.86	-69.1	-0.89	-129.8
6.000	-0.34	-115.2	-66.23	84.2	-12.12	-123.6	-1.77	-159.0
7.000	-0.35	-134.1	-72.40	-58.1	1.34	145.9	-3.35	168.8
8.000	-0.45	-154.1	-73.93	-13.6	7.48	75.4	-6.63	141.1
9.000	-0.52	-175.4	-72.23	-7.1	11.96	18.3	-9.34	119.1
10.000	-0.75	160.3	-66.01	-34.2	15.54	-28.2	-13.97	85.5
11.000	-1.21	132.1	-60.26	-60.3	18.30	-72.2	-22.57	53.2
12.000	-2.33	97.8	-56.60	-94.9	19.92	-116.5	-39.69	-60.4
13.000	-4.60	57.2	-53.53	-135.9	21.36	-163.1	-30.19	-133.1
14.000	-8.86	8.5	-52.43	-173.4	22.49	149.3	-25.30	-127.8
15.000	-16.48	-40.4	-52.50	157.8	23.60	100.6	-21.56	-134.5
16.000	-24.70	-70.2	-52.26	135.4	23.89	62.2	-19.34	-144.1
17.000	-27.75	-80.6	-52.62	108.9	24.01	28.4	-17.60	-158.0
18.000	-23.51	-87.4	-51.36	100.6	23.66	-1.9	-16.51	-172.3
19.000	-21.41	-95.7	-51.27	60.6	23.52	-30.5	-16.34	163.7
20.000	-18.63	-107.0	-54.07	52.8	23.46	-57.8	-17.75	149.6
21.000	-16.77	-115.6	-55.06	30.3	23.11	-84.4	-19.33	131.6
22.000	-14.95	-123.2	-57.35	23.7	23.14	-111.0	-22.26	113.9
23.000	-13.73	-132.0	-59.54	8.0	22.82	-137.3	-25.44	89.1
24.000	-12.59	-138.8	-60.85	32.3	22.36	-162.8	-29.95	43.8
25.000	-11.60	-144.7	-62.07	49.5	22.01	171.8	-28.26	-24.5
26.000	-10.61	-149.8	-54.29	40.2	21.46	147.9	-22.90	-58.9
27.000	-9.34	-154.5	-55.03	23.9	20.91	125.0	-19.22	-84.3
28.000	-7.89	-160.6	-52.05	-11.6	20.49	102.3	-17.12	-102.6
29.000	-6.63	-171.3	-60.41	-22.1	20.06	78.5	-16.20	-114.2
30.000	-5.86	179.9	-56.56	23.2	19.50	55.4	-14.73	-123.1
31.000	-4.83	172.0	-52.73	-13.7	19.03	31.5	-13.72	-137.5
32.000	-3.95	161.7	-54.11	-40.7	18.31	6.9	-13.60	-147.0
33.000	-3.18	151.2	-54.59	-51.2	17.51	-17.5	-13.61	-155.8
34.000	-2.61	140.2	-55.15	-37.9	16.54	-42.3	-14.22	-161.4
35.000	-2.15	129.3	-51.68	-92.2	15.35	-66.8	-14.94	-161.8
36.000	-1.77	117.9	-57.64	-111.2	13.94	-91.0	-15.31	-154.5
37.000	-1.65	106.7	-60.87	-68.5	12.41	-114.4	-13.87	-143.9
38.000	-1.64	95.9	-53.10	-33.4	10.67	-137.5	-11.60	-140.4
39.000	-1.65	85.9	-47.45	-99.7	8.76	-159.6	-9.18	-143.5
40.000	-1.76	75.2	-46.80	-137.0	6.70	178.9	-7.06	-151.0

Typical on Wafer Measurements

Bias conditions: $V_d = 4.5V$, $I_d = 55mA$

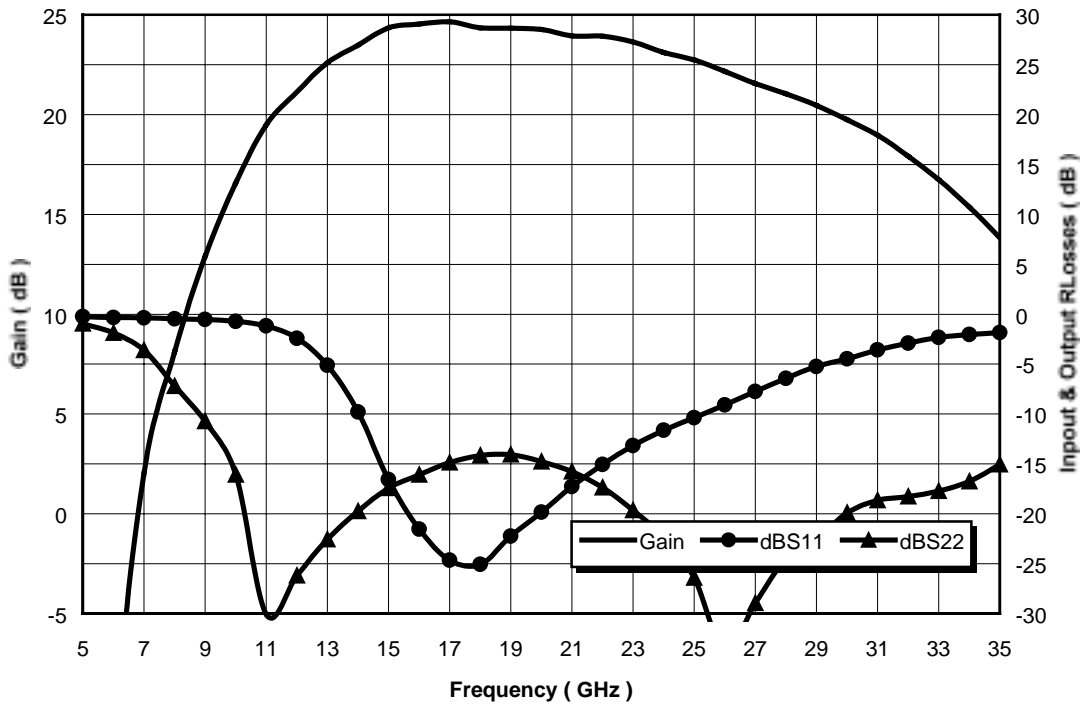
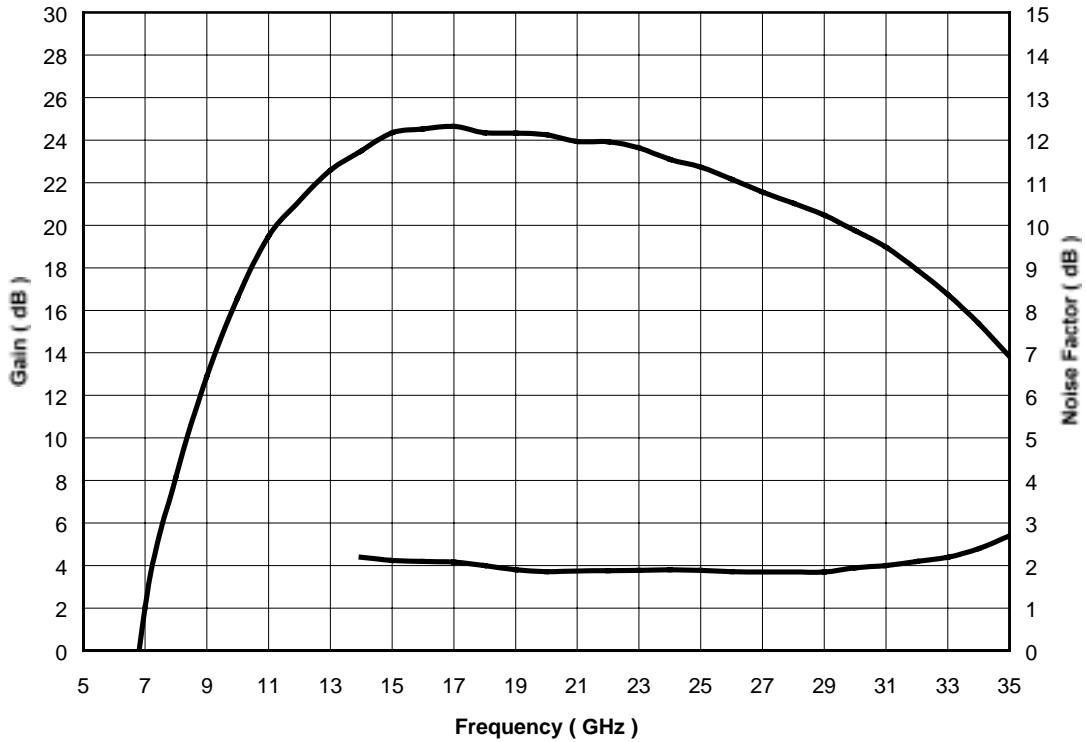

Typical on Test Jig Measurements

Bias conditions: $V_d = 4.5V$, $I_d = 55mA$

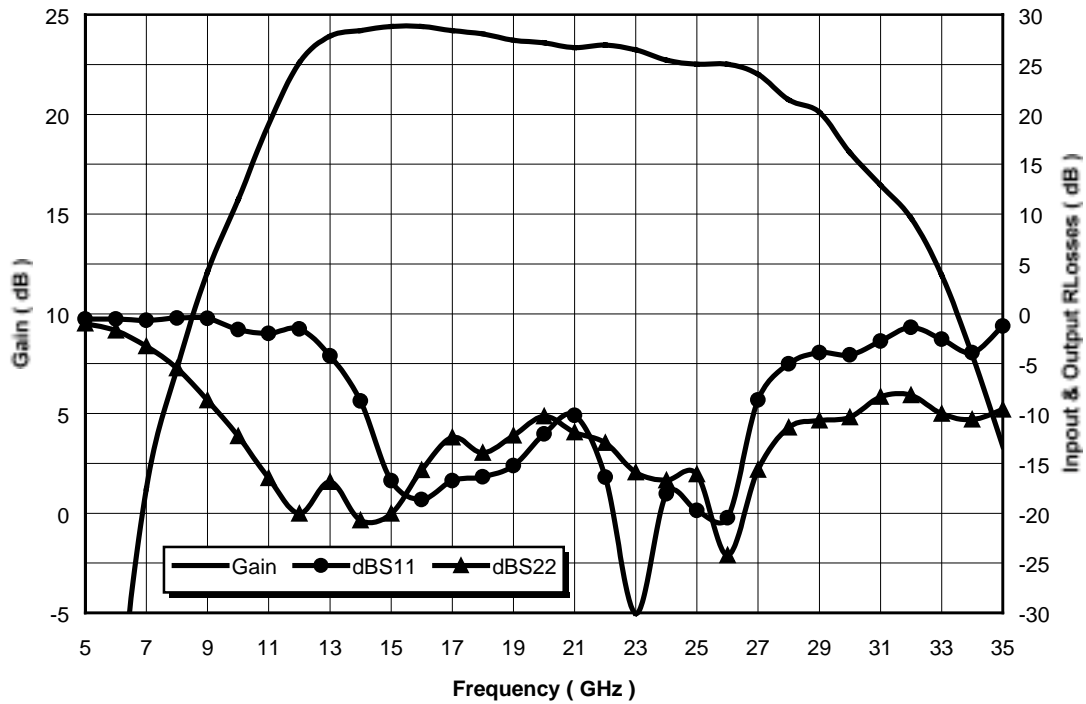
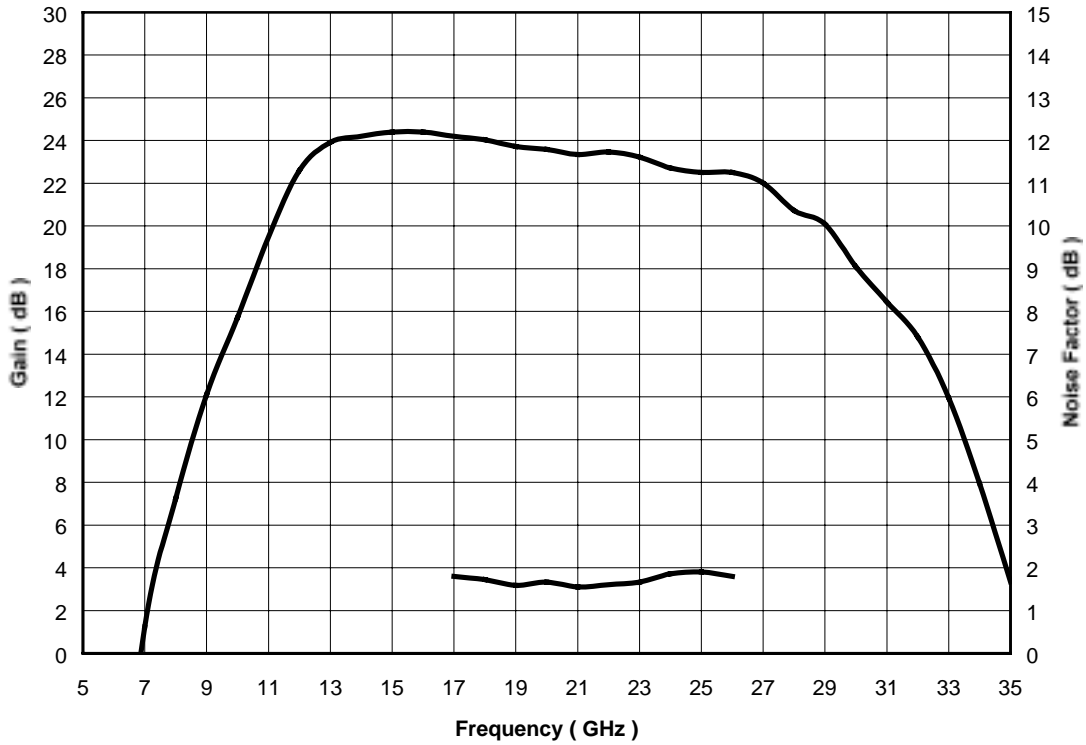

Chip Assembly and Mechanical Data

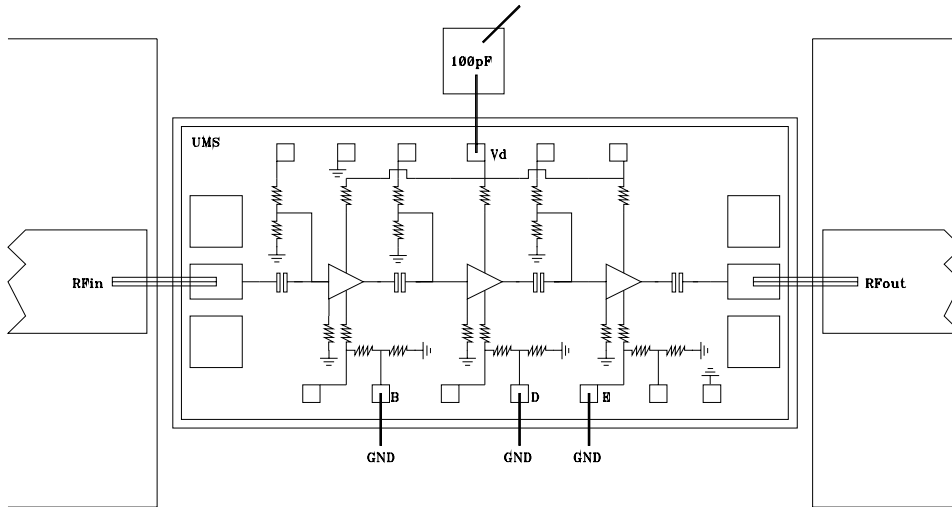

Note : Supply feed should be capacitively bypassed. 25µm diameter gold wire is to be preferred.

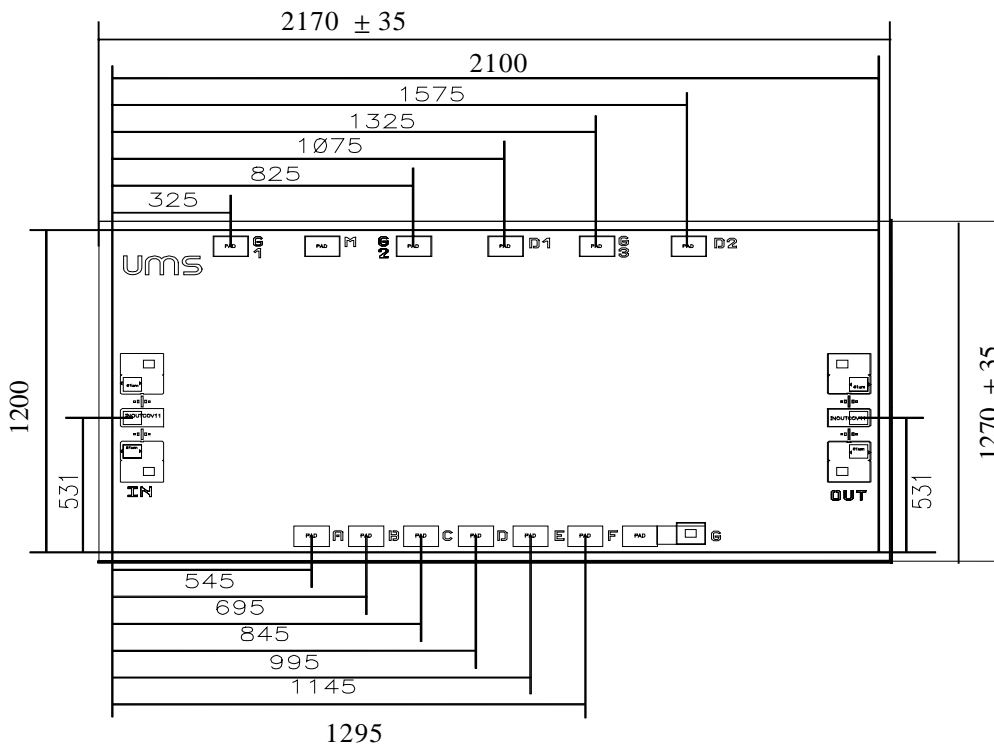

Bonding pad positions.

(Chip thickness : 100µm. Pad size : 100x80µm²)
 (All dimensions are in micrometers)

Chip Biasing options

This chip is self-biased, and flexibility is provided by the access to number of pads. the internal DC electrical schematic is given in order to use these pads in a safe way.

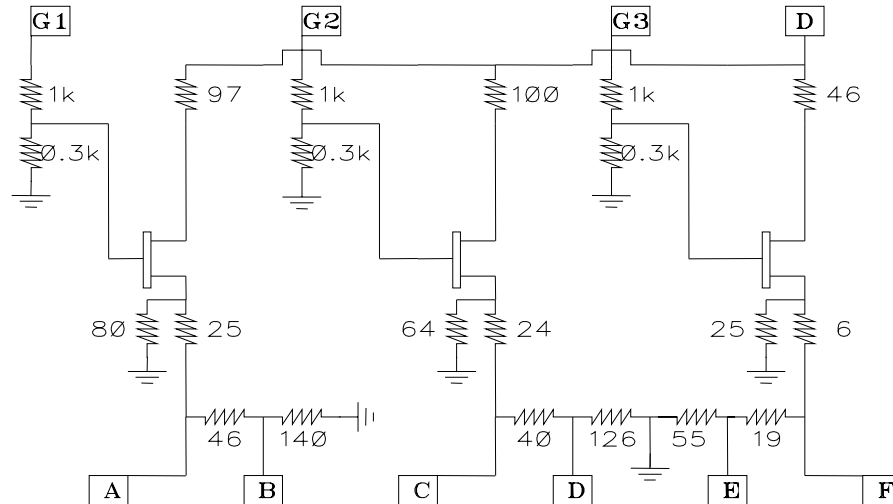

The two requirements are :

N°1 : Not exceed $V_{ds} = 3.5\text{V}$ (internal Drain to Source voltage).

N°2 : Not biased in such a way that V_{gs} becomes positive.

(internal Gate to Source voltage)

We propose two standard biasing :

Low Noise and low consumption :

$V_d = 4.5\text{V}$ and B, D, E grounded.

All the other pads non connected (NC).

$I_{dd} = 55\text{mA}$ & $P_{out-1dB} = 10\text{dBm}$ Typical.

(Equivalent to A,B,C,D,E F: non connected and $V_d=4.5\text{V}$; $G1=G2=G3=+1\text{V}$).

Low Noise and higher output power

$V_d = 4.5\text{V}$ and B, C, F grounded.

All the other pads non connected (NC).

$I_{dd} = 75\text{mA}$ & $P_{out-1dB} = 12\text{dBm}$ Typical..

Ordering Information

Chip form : CHA2090-99F/00

Information furnished is believed to be accurate and reliable. However **United Monolithic Semiconductors S.A.S.** assumes no responsibility for the consequences of use of such information nor for any infringement of patents or other rights of third parties which may result from its use. No license is granted by implication or otherwise under any patent or patent rights of **United Monolithic Semiconductors S.A.S.**. Specifications mentioned in this publication are subject to change without notice. This publication supersedes and replaces all information previously supplied. **United Monolithic Semiconductors S.A.S.** products are not authorised for use as critical components in life support devices or systems without express written approval from **United Monolithic Semiconductors S.A.S.**