

Features

- 3.3V operation with 5V tolerant inputs and I/O's
- 2,432 x 2,432 channel non-blocking switching among local streams
- 4,096 x 2,432 channel blocking switching between backplane and local streams
- 2,048 x 2,048 channel non-blocking switching among backplane streams
- Rate conversion between backplane and local streams
- Rate conversion among local streams
- Backplane interface accepts data rates of 8.192Mb/s or 16.384Mb/s
- Local interface accepts data rates of 2.048Mb/s, 4.096Mb/s or 8.192Mb/s
- Sub-rate switching (2 or 4 bits) configuration for local streams at a data rate of 2.048Mb/s
- Per-channel variable or constant throughput delay
- Fully compliant to H.110 Timing specifications
- Automatic frame offset delay measurement for backplane streams
- Per-stream input frame delay offset, up to 128 bytes, programmable for local streams on a per quarter bit or per channel basis
- Per-stream output frame advancement, programmable for backplane and local streams
- Per-channel direction control for backplane streams
- Per-channel message mode for backplane and local streams
- Per-channel high impedance output control for backplane and local streams
- Pseudo-Random Binary Sequence (PRBS) pattern generation and testing for backplane and local streams
- 5V tolerant PCI driver on CT-Bus I/O's
- Integrated PLL, compatible to Stratum 4 Enhanced clock switching standard
- Non-multiplexed microprocessor interface
- Connection memory block programming for fast device initialization
- Tristate-control outputs for external drivers
- Conform to the mandatory requirements of the IEEE-1149.1 (JTAG) standard

DS5279

ISSUE 2

February 2000

Ordering Information

MT90866AL	256 Pin LQFP
MT90866AG	240 Pin LBGA

-40°C to +85°C

Applications

- Multi-service access platforms
- CTI applications
- Gateways, Integrated Access Devices
- ST-BUS and H.110 interface applications

Description

The MT90866 Digital Switch provides switching capacities of 4,096 x 2,432 channels between backplane and local streams, 2,432 x 2,432 channels among local streams and 2,048 x 2,048 channels among backplane streams. The local connected serial inputs and outputs have 32, 64 and 128 64kb/s channels per frame with data rates of 2.048, 4.096 and 8.192Mb/s respectively. The backplane connected serial inputs and outputs have 128 and 256 64kb/s channels per frame with data rates of 8.192 and 16.384Mb/s respectively.

The MT90866 also offers a sub-rate switching configuration which allows 2-bit wide 16kb/s or 4-bit wide 32kb/s data channels to be switched within the device.

The device has features that are programmable on per-stream or per-channel basis including message mode, input delay offset, output advancement offset, direction control and high impedance output control.

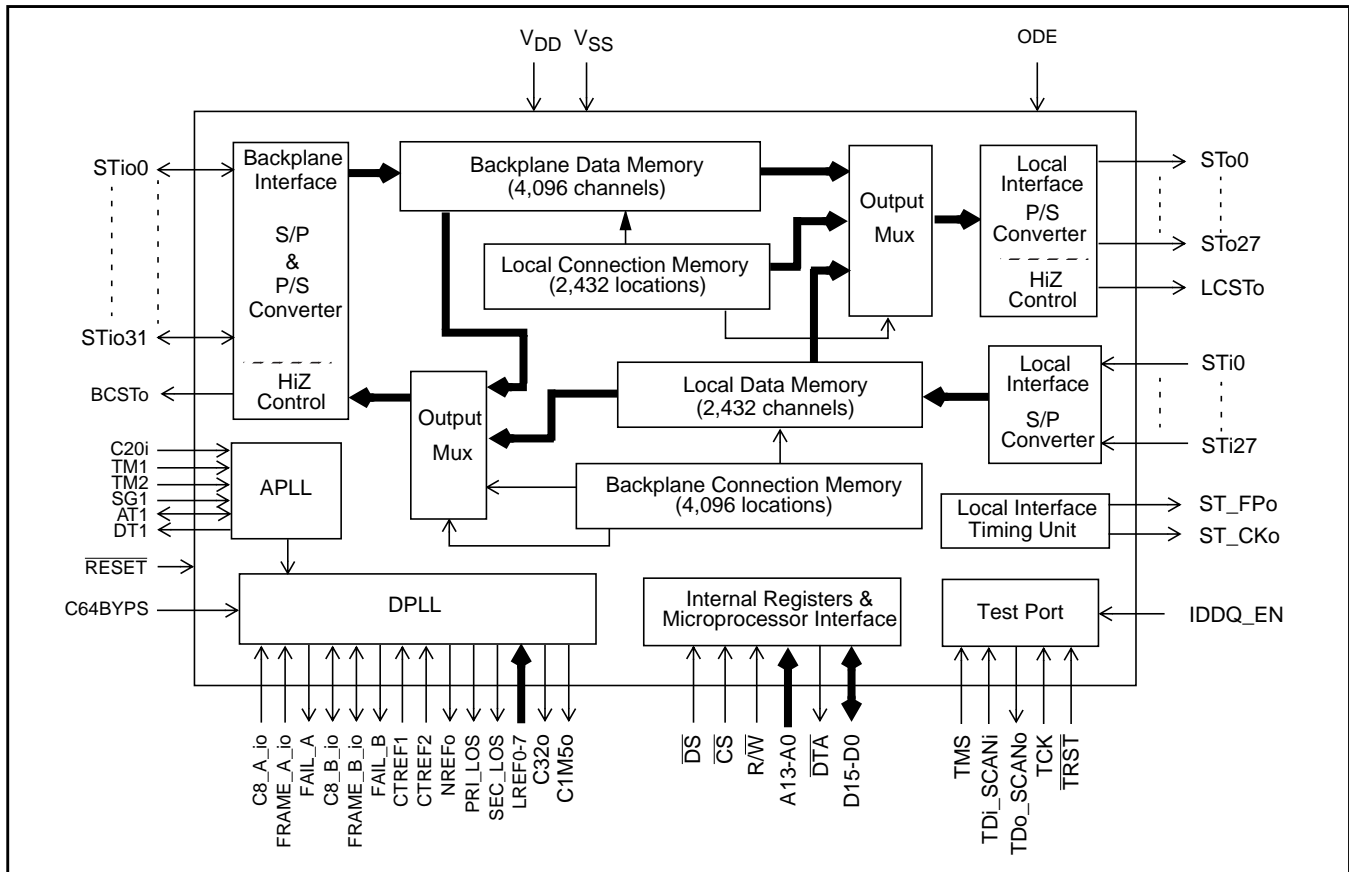

Figure 1 - Functional Block Diagram

Application Overview

The MT90866 is intended for carrier-grade applications that require high bandwidth switching capability. With compliance to the ECTF H.110 specification, it is also suitable for using a compact PCI platform.

While the Computer Telephony Interface (CTI) industry is adopting the compact PCI platform over VME, many manufacturers of telecom and datacom equipment are also selecting this platform. The compact PCI platform offers attractive features such as hot swappable cards, integrated PCI and H.110 TDM buses, and a rugged backplane and mechanical design. This new standard is replacing the older ribbon-cable based bus standards such as MVIP-90, H-MVIP and SCbus.

Carrier-grade access, switching platforms, wireless base stations, and gateways (i.e. VOIP) may handle multiple T1/E1, DS-3 or OC-3 streams for connection to the WAN or PSTN. Multiple lower bandwidth interfaces are consolidated into these higher bandwidth pipes for networking into a WAN or PSTN.

While these types of equipment serve different applications and markets, many share a similar type

of internal architecture. Frequently, a mid-plane or backplane configuration is used, which may accommodate a TDM bus, for compatibility to TDM interfaces (ISDN, Sonet, T1/E1, etc.), and a PCI bus, for interfacing to LAN networks and the IP network. In many cases, a Utopia bus may be present if ATM is used as an uplink to the WAN or PSTN. Interfacing into this midplane or backplane would be lower bandwidth subscriber linecards and higher bandwidth WAN uplink linecards.

By locating TDM switching on the linecard itself, as opposed to a centralized switching card, system designers employ a distributed switching arrangement. In this case, the MT90866 allows for local to backplane switching of DS-0 traffic from trunks or local connection such as internal DSP cards (compression, echo cancellation, modem termination). Unique to the industry, the MT90866 provides backplane switching, eliminating the need to move the traffic to the local streams and back. This feature allows users to move traffic among the backplane traces for routing to other destinations.

On the uplink linecard side, the MT90866 allows the users to interface to multiple T1 or E1 or DS-3 or OC-3 ports. With the ability to take 2,432 channels from 4,096 channels on the backplane and to switch

them to the local streams, the MT90866 satisfies these higher bandwidth applications.

Depending on the application, the CPE or access equipment may need to terminate internet traffic and switch the traffic to the appropriate destination. Most of these applications employ banks of DSP's to handle the modem calls. When the local streams are used to route traffic to these DSP cards, the

application requires a high local switching capability on each card. This requirement is easily handled by the MT90866, with its local switching capacity of 2,432 channels.

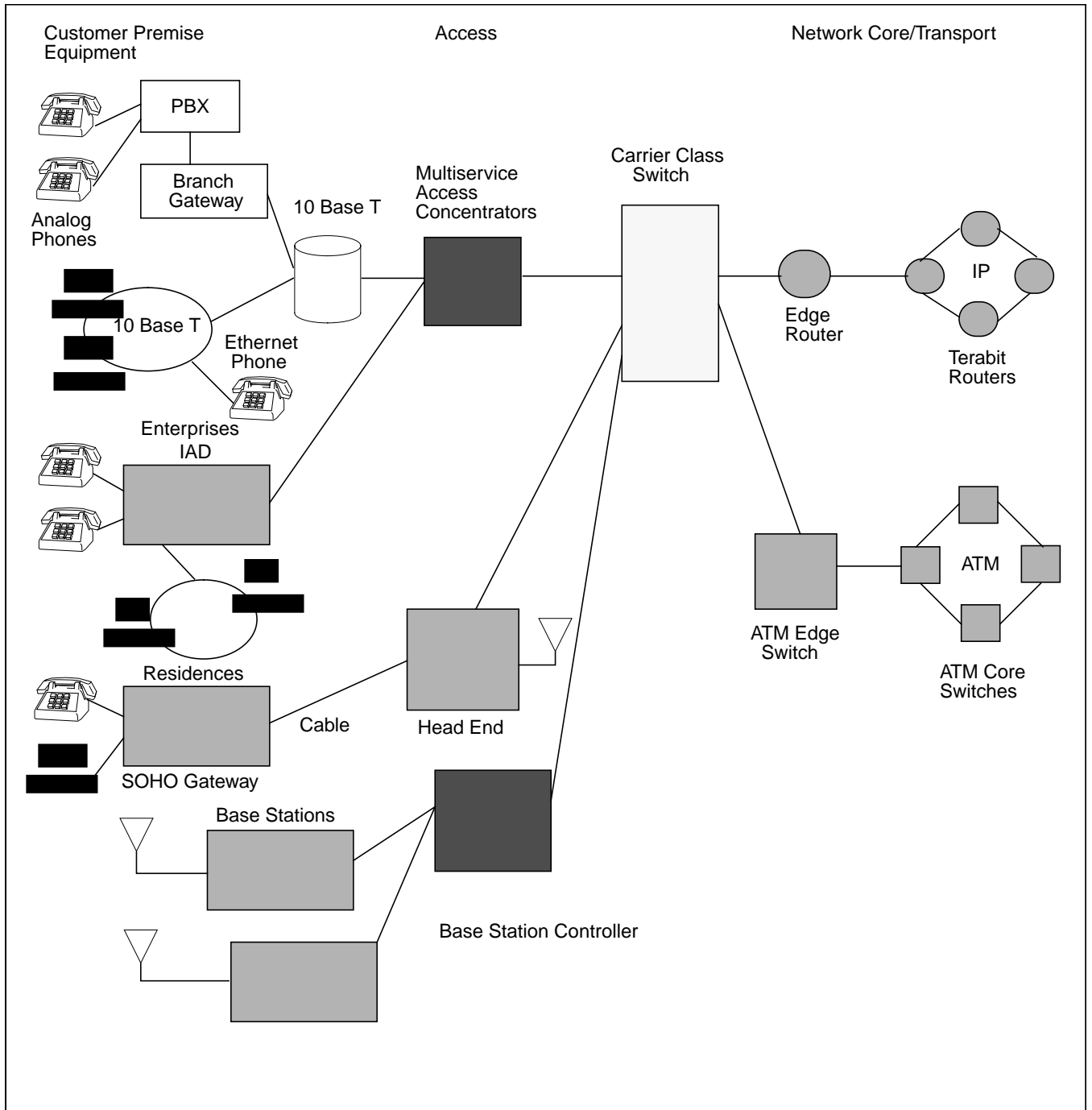

Figure 2 - Typical Network Block Diagram

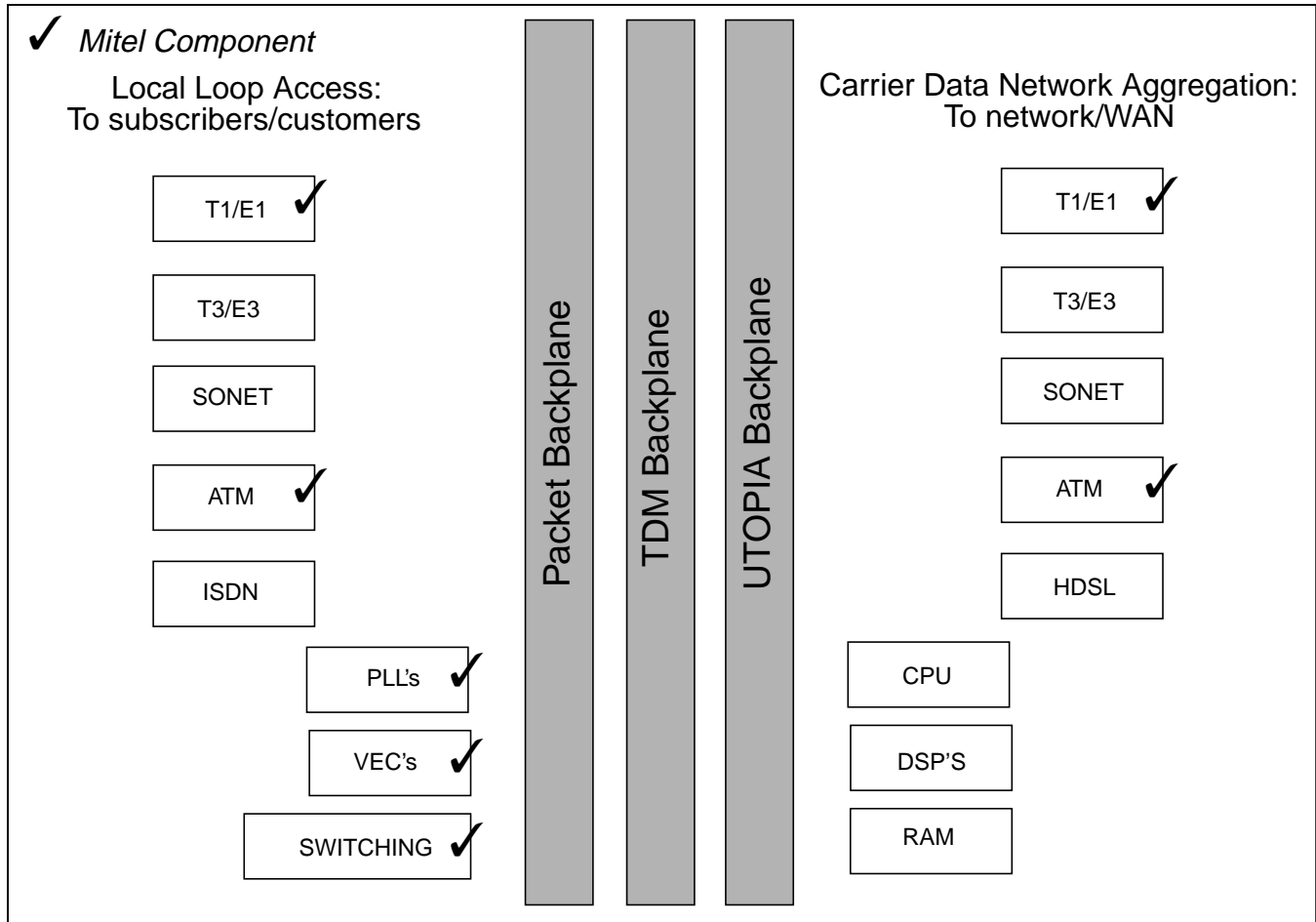

Figure 3 - Carrier Multi-service Access Switch

Notes:



<http://www.mitelsemi.com>

World Headquarters - Canada

Tel: +1 (613) 592 2122
Fax: +1 (613) 592 6909

North America

Tel: +1 (770) 486 0194
Fax: +1 (770) 631 8213

Asia/Pacific

Tel: +65 333 6193
Fax: +65 333 6192

**Europe, Middle East,
and Africa (EMEA)**

Tel: +44 (0) 1793 518528
Fax: +44 (0) 1793 518581

Information relating to products and services furnished herein by Mitel Corporation or its subsidiaries (collectively "Mitel") is believed to be reliable. However, Mitel assumes no liability for errors that may appear in this publication, or for liability otherwise arising from the application or use of any such information, product or service or for any infringement of patents or other intellectual property rights owned by third parties which may result from such application or use. Neither the supply of such information or purchase of product or service conveys any license, either express or implied, under patents or other intellectual property rights owned by Mitel or licensed from third parties by Mitel, whatsoever. Purchasers of products are also hereby notified that the use of product in certain ways or in combination with Mitel, or non-Mitel furnished goods or services may infringe patents or other intellectual property rights owned by Mitel.

This publication is issued to provide information only and (unless agreed by Mitel in writing) may not be used, applied or reproduced for any purpose nor form part of any order or contract nor to be regarded as a representation relating to the products or services concerned. The products, their specifications, services and other information appearing in this publication are subject to change by Mitel without notice. No warranty or guarantee express or implied is made regarding the capability, performance or suitability of any product or service. Information concerning possible methods of use is provided as a guide only and does not constitute any guarantee that such methods of use will be satisfactory in a specific piece of equipment. It is the user's responsibility to fully determine the performance and suitability of any equipment using such information and to ensure that any publication or data used is up to date and has not been superseded. Manufacturing does not necessarily include testing of all functions or parameters. These products are not suitable for use in any medical products whose failure to perform may result in significant injury or death to the user. All products and materials are sold and services provided subject to Mitel's conditions of sale which are available on request.

M Mitel (design) and ST-BUS are registered trademarks of MITEL Corporation
Mitel Semiconductor is an ISO 9001 Registered Company
Copyright 1999 MITEL Corporation
All Rights Reserved
Printed in CANADA

TECHNICAL DOCUMENTATION - NOT FOR RESALE