

UTC2SA684 PNP EPITAXIAL PLANAR TRANSISTOR

PNP EPITAXIAL PLANAR TRANSISTOR

DESCRIPTION

The UTC 2SA684 is power amplifier and driver.

FEATURES

- *Automatic insertion by radial taping possible.
- *Complementary pair with 2SC1384

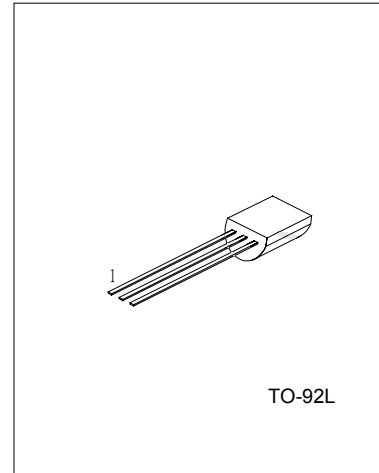

1:EMITTER 2:COLLECTOR 3:BASE

ABSOLUTE MAXIMUM RATINGS (Ta=25°C , unless otherwise specified)

PARAMETER	SYMBOL	VALUE	UNIT
Collector-Base Voltage	VCBO	60	V
Collector-Emitter Voltage	VCEO	50	V
Emitter-Base Voltage	VEBO	5	V
Peak Collector Current	Icp	1.5	A
Collector Current(DC)	Ic	1	A
Collector Dissipation(Ta=25°C)	Pc	1	W
Junction Temperature	Tj	150	°C
Storage Temperature	TSTG	-55 ~ +150	°C

ELECTRICAL CHARACTERISTICS(Ta=25°C, unless otherwise specified)

PARAMETER	SYMBOL	TEST CONDITIONS	MIN	TYP	MAX	UNIT
Collector Cut-Off Current	ICBO	VCB=20V, IE=0			0.1	μA
Collector-Base Voltage	VCBO	Ic=10μA, IE=0	60			V
Collector-Emitter Voltage	VCEO	Ic=2mA, IB=0	50			V
Emitter-Base Voltage	VEBO	IE=10μA, Ic=0	5			V
DC Current Gain	hFE1	VCE=10V, Ic=500mA	85		340	
	hFE2	VCE=5V, IB=1A	50			
Collector-Emitter Saturation Voltage	VCE(sat)	Ic=0.5A, IB=50mA		0.2	0.4	V
Base-Emitter Saturation Voltage	VBE(sat)	Ic=0.5A, IB=50mA		0.85	1.2	V
Current Gain Bandwidth Product	ft	VCE=10V, IB=50mA, f=200MHz		200		MHz
Output Capacitance	Cob	VCB=10V, IE=0, f=1MHz		20	30	pF

UTC2SA684 PNP EPITAXIAL PLANAR TRANSISTOR

CLASSIFICATION OF hFE

RANK	Q	R	S
RANGE	85-170	120-240	170-340

UTC assumes no responsibility for equipment failures that result from using products at values that exceed, even momentarily, rated values (such as maximum ratings, operating condition ranges, or other parameters) listed in products specifications of any and all UTC products described or contained herein. UTC products are not designed for use in life support appliances, devices or systems where malfunction of these products can be reasonably expected to result in personal injury. Reproduction in whole or in part is prohibited without the prior written consent of the copyright owner. The information presented in this document does not form part of any quotation or contract, is believed to be accurate and reliable and may be changed without notice.