



SD56120

RF POWER TRANSISTORS

The *LdmoST* FAMILY

PRELIMINARY DATA

N-CHANNEL ENHANCEMENT-MODE LATERAL MOSFETs

- EXCELLENT THERMAL STABILITY
- COMMON SOURCE CONFIGURATION, PUSH-PULL
- P_{OUT} = 100 W WITH 14 dB GAIN @ 860 MHz
- BeO FREE PACKAGE

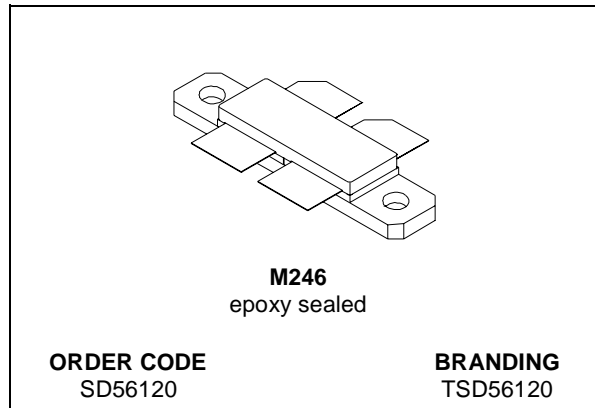

DESCRIPTION

The SD56120 is a common source N-Channel enhancement-mode lateral Field-Effect RF power transistor designed for broadband commercial and industrial applications at frequencies up to 1.0 GHz. The SD56120 is designed for high gain and broadband performance operating in common source mode at 28 V. It is ideal for broadcast applications from 470 to 860 MHz requiring high linearity.

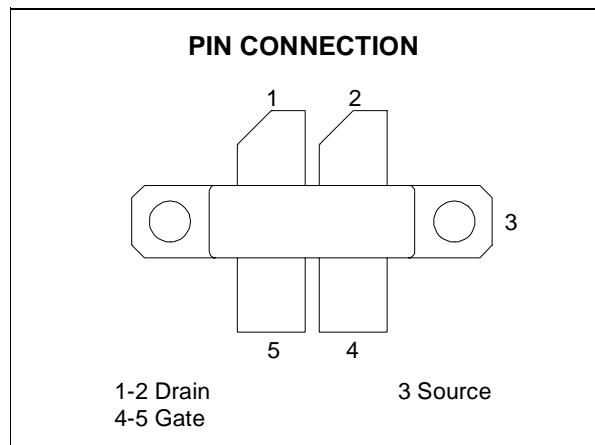

ABSOLUTE MAXIMUM RATINGS (T_{case} = 25°C)

Symbol	Parameter	Value	Unit
V _{(BR)DSS}	Drain-Source Voltage	65	V
V _{GS}	Gate-Source Voltage	± 20	V
I _D	Drain Current	14	A
P _{DISS}	Power Dissipation (@ T _c = 70°C)	217	W
T _j	Max. Operating Junction Temperature	200	°C
T _{STG}	Storage Temperature	-65 to +150	°C

THERMAL DATA

R _{th(j-c)}	Junction -Case Thermal Resistance	0.6	°C/W
----------------------	-----------------------------------	-----	------

ELECTRICAL SPECIFICATION ($T_{CASE} = 25^{\circ}C$)

STATIC (Per Section)

Symbol	Test Conditions		Min.	Typ.	Max.	Unit
$V_{(BR)DSS}$	$V_{GS} = 0\text{ V}$	$I_{DS} = 1\text{ mA}$	65			V
I_{DSS}	$V_{GS} = 0\text{ V}$	$V_{DS} = 28\text{ V}$			1	μA
I_{GSS}	$V_{GS} = 20\text{ V}$	$V_{DS} = 0\text{ V}$			1	μA
$V_{GS(Q)}$	$V_{DS} = 28\text{ V}$	$I_D = 200\text{ mA}$	3.0		5.0	V
$V_{DS(ON)}$	$V_{GS} = 10\text{ V}$	$I_D = 3\text{ A}$		0.7	0.8	V
G_{FS}	$V_{DS} = 10\text{ V}$	$I_D = 3\text{ A}$		3		mho
C_{ISS}	$V_{GS} = 0\text{ V}$	$V_{DS} = 28\text{ V}$		82		pF
C_{OSS}	$V_{GS} = 0\text{ V}$	$V_{DS} = 28\text{ V}$		48		pF
C_{RSS}	$V_{GS} = 0\text{ V}$	$V_{DS} = 28\text{ V}$		2.8		pF

REF. 7194566A

DYNAMIC

Symbol	Test Conditions		Min.	Typ.	Max.	Unit
P_{OUT}	$V_{DD} = 28\text{ V}$	$I_{DQ} = 400\text{ mA}$ $f = 860\text{ MHz}$	100			W
G_{PS}	$V_{DD} = 28\text{ V}$	$I_{DQ} = 400\text{ mA}$ $P_{OUT} = 100\text{ W}$ $f = 860\text{ MHz}$	14	16		dB
η_D	$V_{DD} = 28\text{ V}$	$I_{DQ} = 400\text{ mA}$ $P_{OUT} = 100\text{ W}$ $f = 860\text{ MHz}$	50	60		%
G_{PS}	$V_{DD} = 28\text{ V}$	$I_{DQ} = 400\text{ mA}$ $P_{OUT} = 100\text{ W PEP}$		16		dB
η_D	$V_{DD} = 28\text{ V}$	$I_{DQ} = 400\text{ mA}$ $P_{OUT} = 100\text{ W PEP}$		50		%
IMD	$V_{DD} = 28\text{ V}$	$I_{DQ} = 400\text{ mA}$ $P_{OUT} = 100\text{ W PEP}$		-28		dB_t
Load mismatch	$V_{DD} = 28\text{ V}$	$I_{DQ} = 400\text{ mA}$ $P_{OUT} = 100\text{ W}$ $f = 860\text{ MHz}$ ALL PHASE ANGLES	5:1			VSWR

note: $f_1 = 860\text{ MHz}$
PEP $f_2 = 860.1\text{ MHz}$

IMPEDANCE DATA

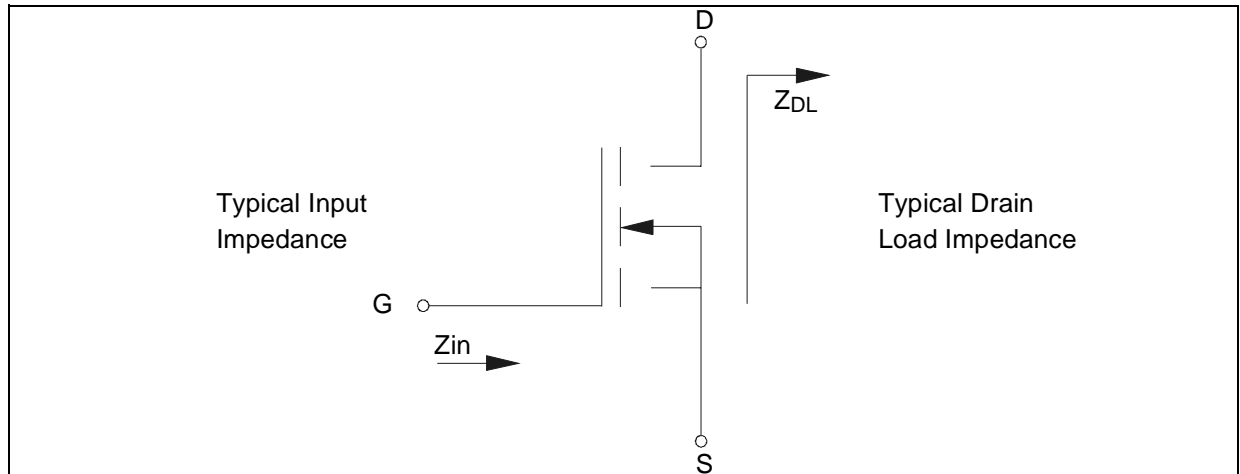

FREQ.	$Z_{IN} (\Omega)$	$Z_{DL} (\Omega)$
860 MHz	$1.11 - j 2.63$	$3.01 + j 5.34$

Measured drain to drain and gate to gate respectively.

TYPICAL PERFORMANCE

Capacitance vs. Drain Voltage (per section)

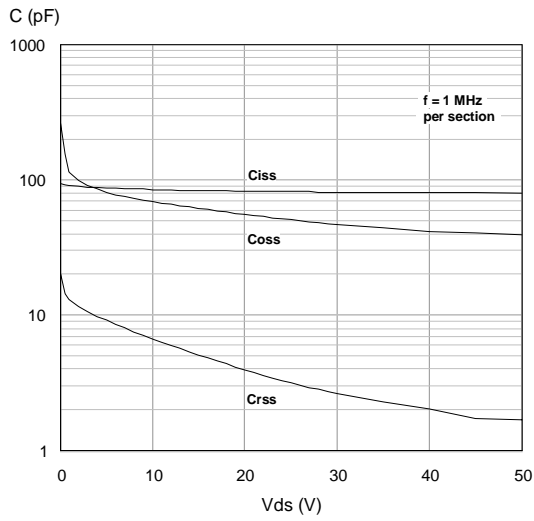

Gate-Source Voltage vs. Case Temperature

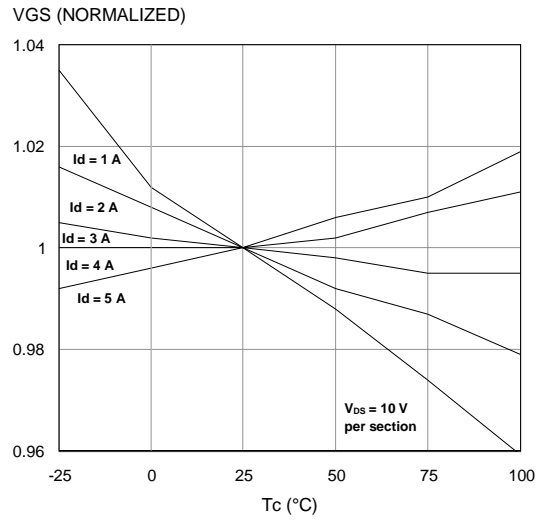

Drain Current vs. Gate Voltage

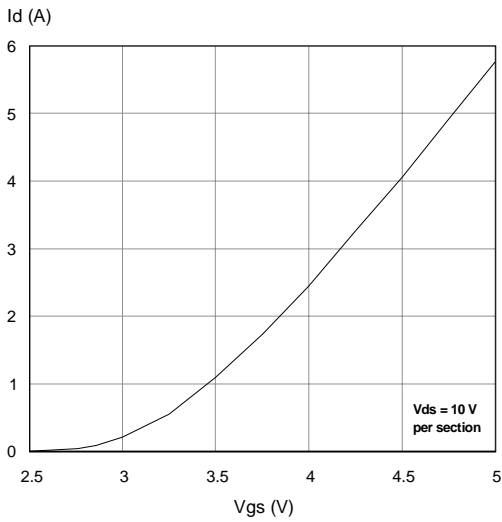

Output Power vs. Input Power

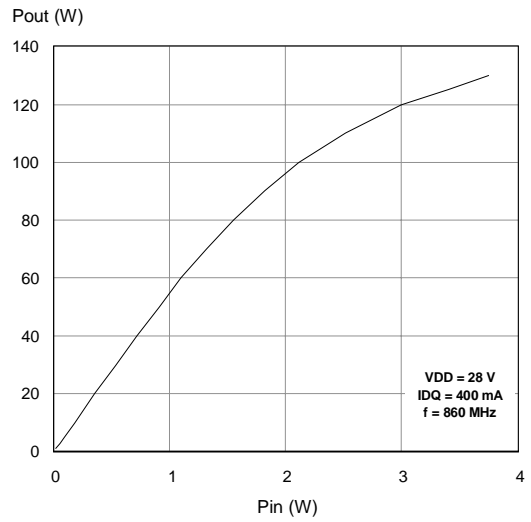

Power Gain vs. Input Power

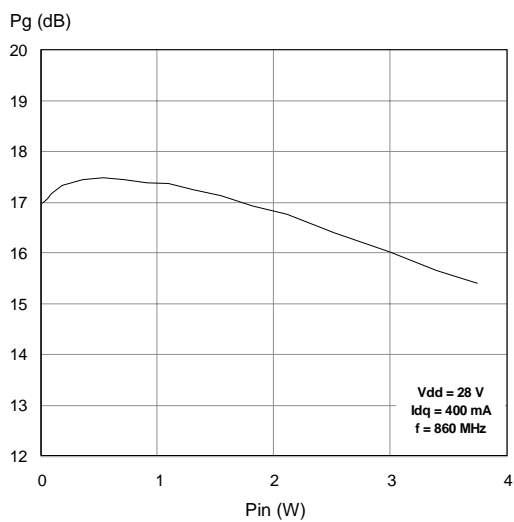

Efficiency vs. Output Power

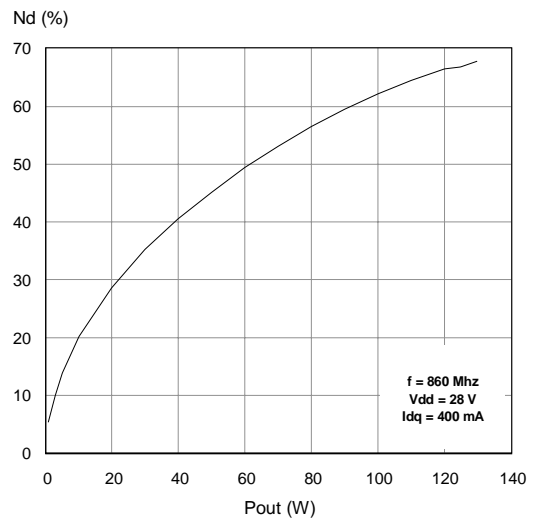

SD56120

TYPICAL PERFORMANCE

Power Gain vs. Output Power

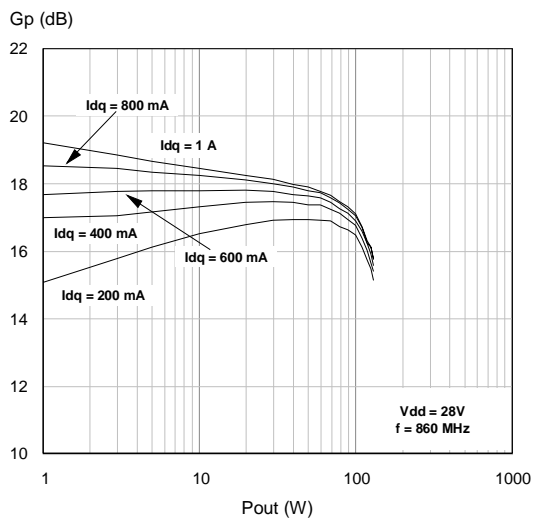

Intermodulation Distortion vs. Output Power

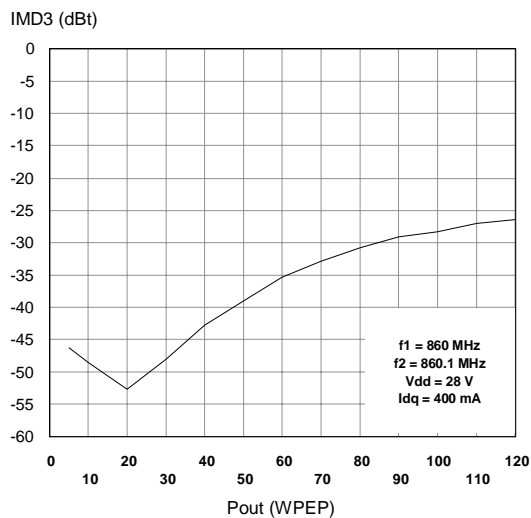

Output Power vs. Drain Voltage

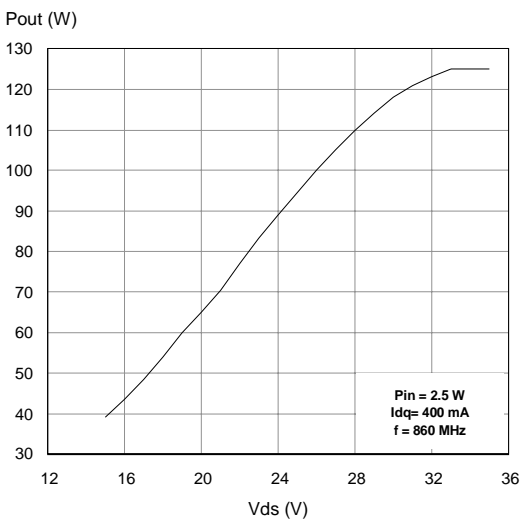

Output Power vs. Bias Current

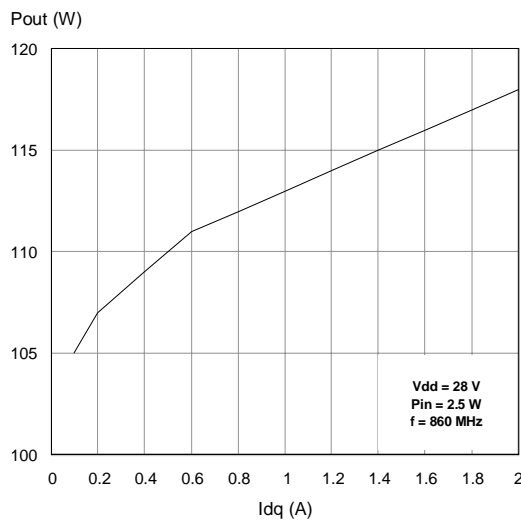

Output Power vs. Gate-Source Voltage

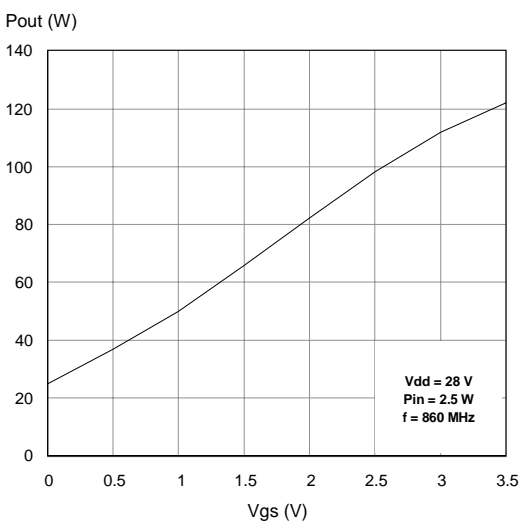

860 MHz TEST CIRCUIT SCHEMATIC

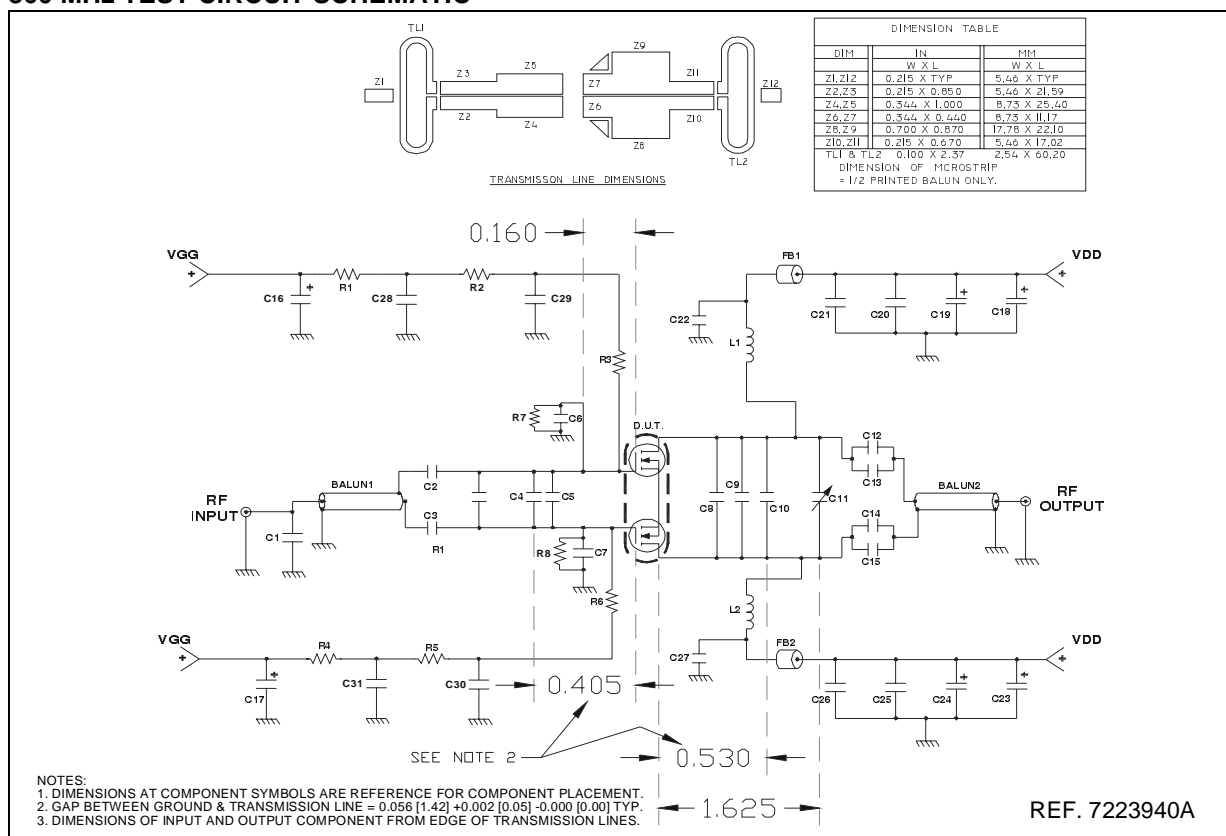

860 MHz TEST CIRCUIT COMPONENT PART LIST

COMPONENT	DESCRIPTION
C32	.6 - 4.5 pF VARIABLE CAPACITOR
C31, C28	.01 μ F ATC 200B SURFACE MOUNT CERAMIC CHIP CAPACITOR
C29, C30	62 pF ATC 100B SURFACE MOUNT CERAMIC CHIP CAPACITOR
C27, C22	270 pF ATC 100B SURFACE MOUNT CERAMIC CHIP CAPACITOR
C26, C21	1200 pF ATC 700B SURFACE MOUNT CERAMIC CHIP CAPACITOR
C25, C20	0.1 μ F 500V SURFACE MOUNT CERAMIC CHIP CAPACITOR
C24, C19, C17, C16	10 μ F 50V ALUMINUM ELECTROLYTIC RADIAL LEAD SURFACE MOUNT CAPACITOR
C23, C18	100 μ F 63V ALUMINUM ELECTROLYTIC RADIAL LEAD CAPACITOR
C15, C14, C13, C12	47 pF ATC 100B SURFACE MOUNT CERAMIC CHIP CAPACITOR
C11	0.8 - 8 pF GIGATRIM VARIABLE CAPACITOR
C10	3.0 pF ATC 100B SURFACE MOUNT CERAMIC CHIP CAPACITOR
C9, C8	4.3 pF ATC 100B SURFACE MOUNT CERAMIC CHIP CAPACITOR
C7, C6, C5	10 pF ATC 100B SURFACE MOUNT CERAMIC CHIP CAPACITOR
C4	2.0 pF ATC 100B SURFACE MOUNT CERAMIC CHIP CAPACITOR
C3, C2	20 pF ATC 100B SURFACE MOUNT CERAMIC CHIP CAPACITOR
C1	1.3 pF ATC 100B SURFACE MOUNT CERAMIC CHIP CAPACITOR
R7, R8	100 OHM 1/4 W SURFACE MOUNT CHIP RESISTOR
R6, R3	22 OHM 1/4 W CARBON LEADED RESISTOR
R5, R2	4.7 OHM 1/4 W CARBON LEADED RESISTOR
R4, R1	82 OHM 1/4 W CARBON LEADED RESISTOR
B2, B1	BALUN, 50 OHM SUCOFORM, OD 0.141 2.37 LG COAXIAL CABLE OR EQUIVALENT
L2, L1	INDUCTOR, 6 TURN AIR-WOUND #18AWG ID=0.130[3,30] MAGNET WIRE
FB2, FB1	SURFACE MOUNT EMI SHIELD BEAD
PCB	ULTRALAM 2000. 0.030" THK $\epsilon_r = 2.55$, 2 Oz ED CU BOTH SIDES

860 MHz PRODUCTION TEST FIXTURE

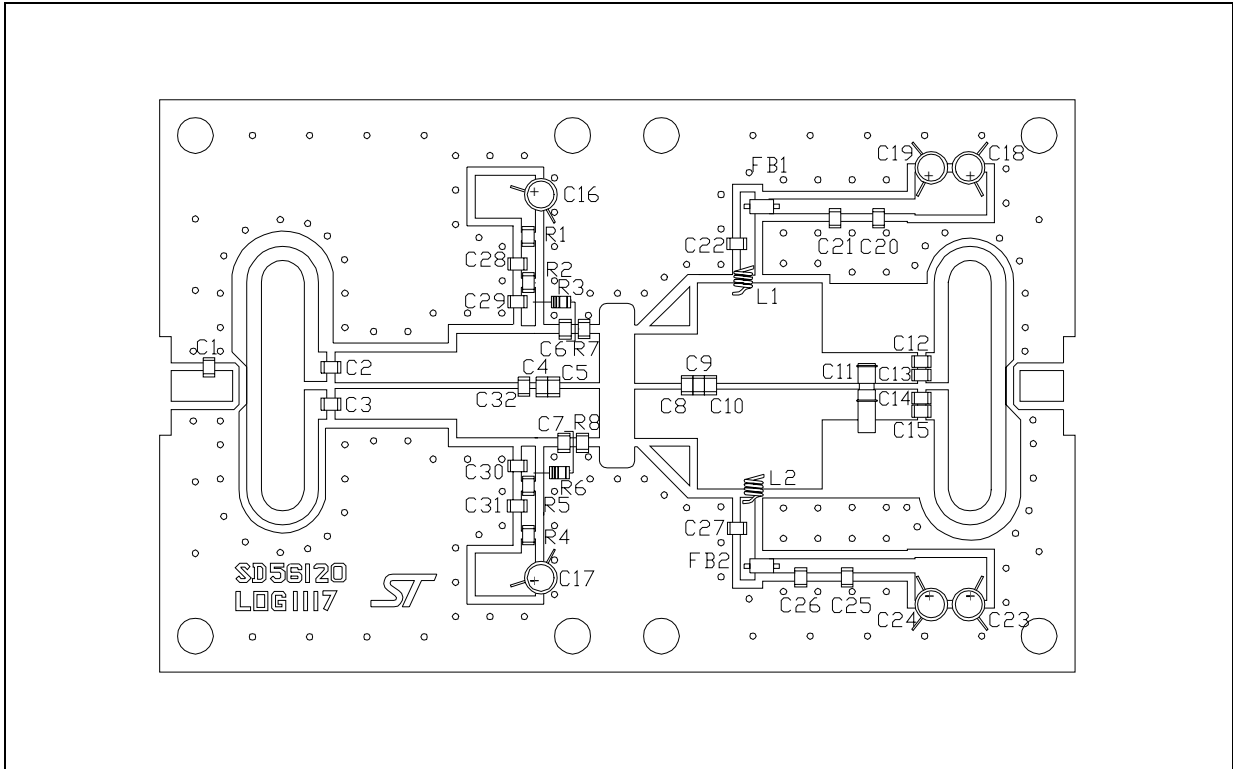

860 MHz TEST CIRCUIT PHOTOMASTER

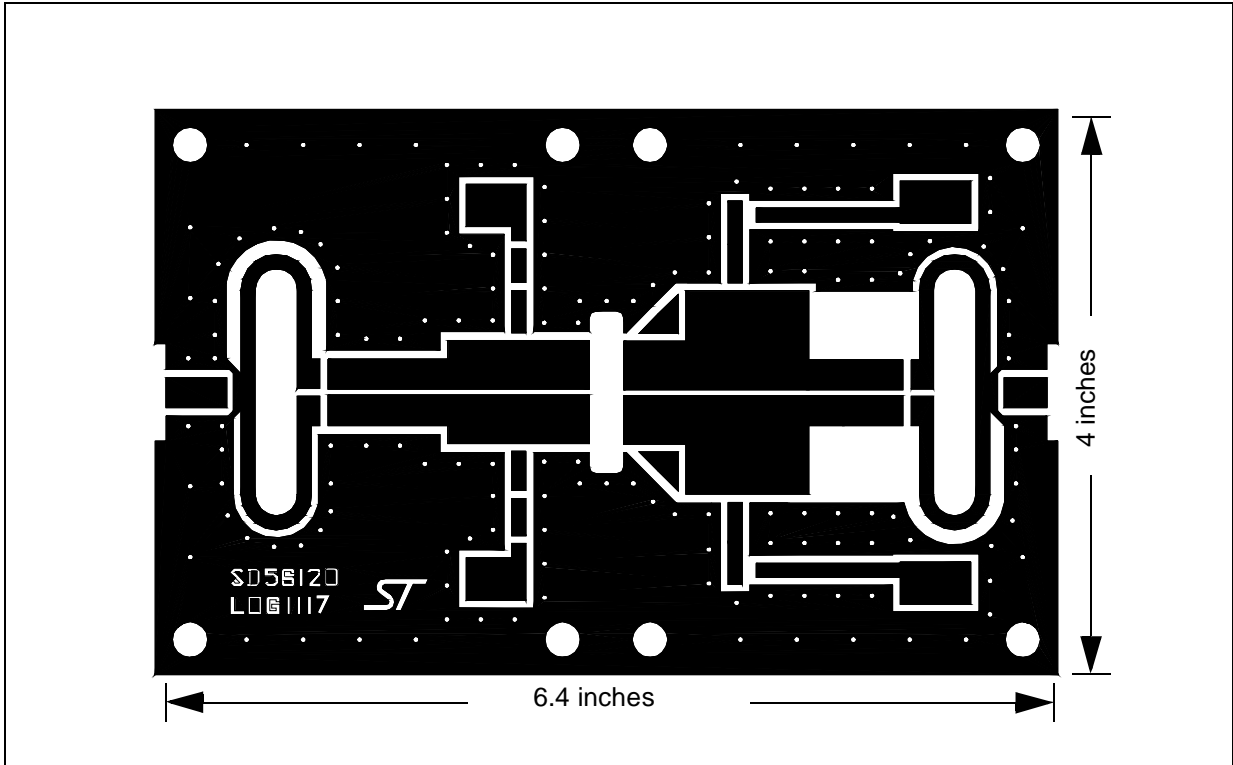

M246 (.230 x .650 WIDE 4/L BAL N/HERM W/FLG) MECHANICAL DATA

	mm			Inch		
	MIN.	TYP.	MAX	MIN.	TYP.	MAX
A	5.33		5.59	.210		.220
B	6.48		6.73	.255		.265
C	17.27		18.29	.680		.720
D	5.72		5.97	.225		.235
E		22.86			.900	
F	28.83		29.08	1.135		1.145
G	16.26		16.76	.640		.660
H	4.19		5.08	.165		.200
I	0.08		0.15	.003		.006
J	1.83		2.24	.072		.088
K	1.40		1.65	.055		.065
L	3.18		3.43	.125		.135

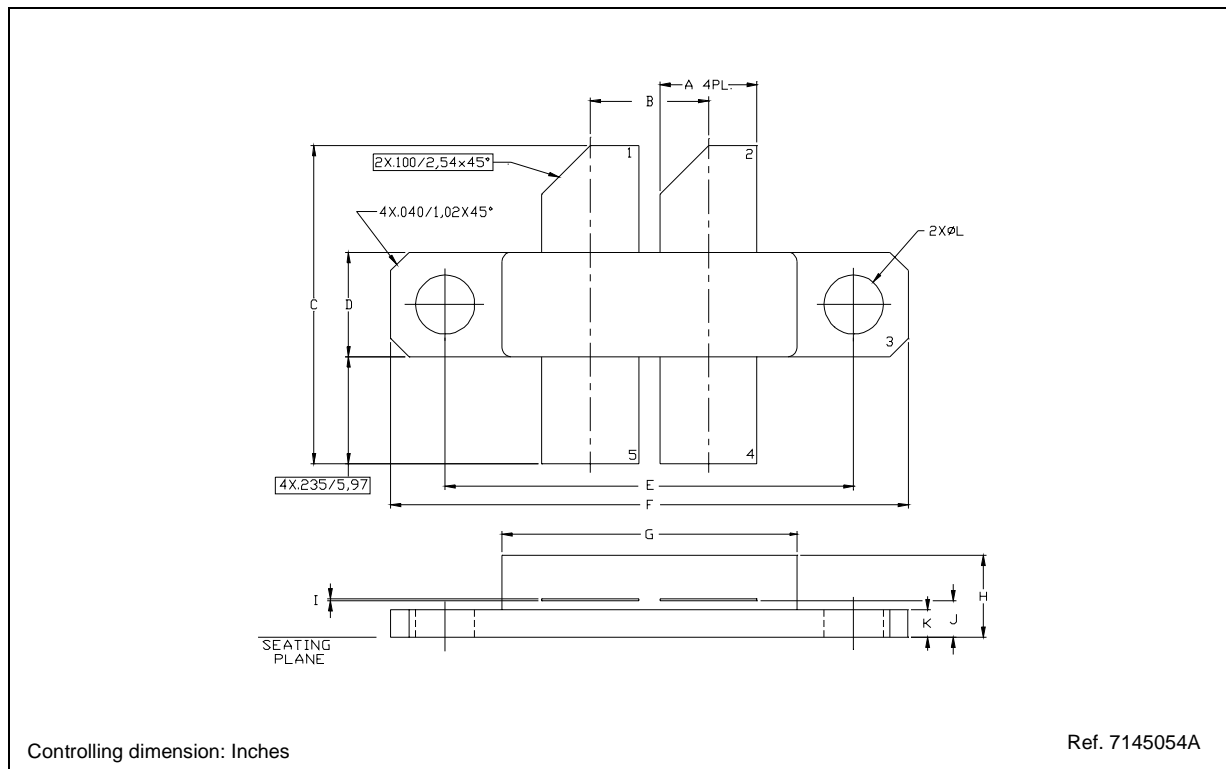

Information furnished is believed to be accurate and reliable. However, STMicroelectronics assumes no responsibility for the consequences of use of such information nor for any infringement of patents or other rights of third parties which may result from its use. No license is granted by implication or otherwise under any patent or patent rights of STMicroelectronics. Specification mentioned in this publication are subject to change without notice. This publication supersedes and replaces all information previously supplied. STMicroelectronics products are not authorized for use as critical components in life support devices or systems without express written approval of STMicroelectronics.

The ST logo is a registered trademark of STMicroelectronics

© 2001 STMicroelectronics - Printed in Italy - All rights reserved

STMicroelectronics GROUP OF COMPANIES

Australia - Brazil - China - Finland - France - Germany - Hong Kong - India - Italy - Japan - Malaysia - Malta - Morocco - Singapore - Spain - Sweden - Switzerland - United Kingdom - U.S.A.

<http://www.st.com>