

Description

The SL5022/P can fulfill the standards of other countries by changing the external component.

Dynamic or piezoelectric type can be used with receiver Each gain is controlled with AGC in accordance with the line current. The SL5022/P can be operated down to DC line 1.6V

Features

- Independent adjustment of DC resistance and AC impedance.
- Voltage regulator with adjustable static resistance
- Symmetrical high-impedance inputs for dynamic magnetic or piezo-electric microphones
- Receiving amplifier for dynamic magnetic or piezo-electric earpieces
- DTMF signal interface
- Low DC line voltage : operated down to 1.6V
- MUTE function
- DC line voltage adjustment facility

Ordering Information

Type NO.	Marking	Package Code
SL5022	SL5022	SOP16
SL5022P	SL5022	DIP16

Outline Dimensions

unit : mm

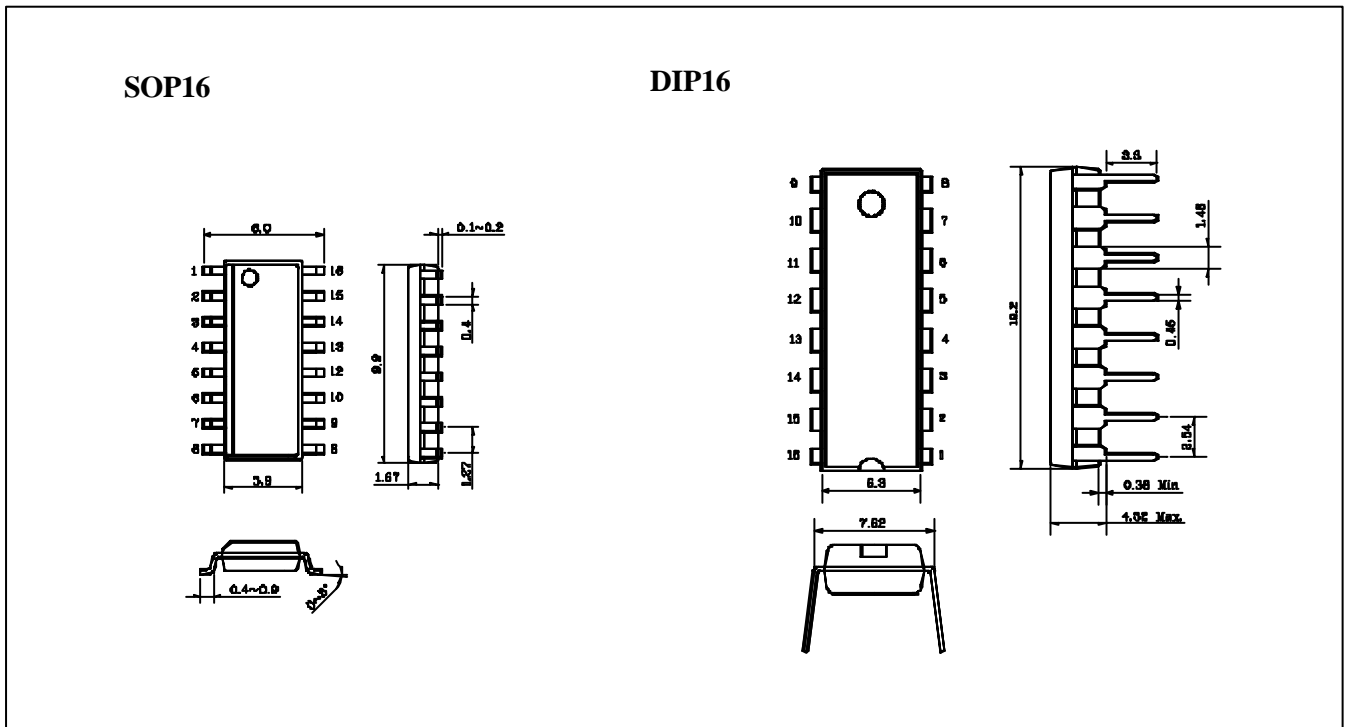

Absolute Maximum Ratings

(Ta = 25° C)

Characteristic	Symbol	Rating	Unit
Line Voltage	V _L	12	V
Line Current	I _L	140	mA
Power Dissipation	P _D	666	mW
Operating Temperature	T _{opr}	-25 ~ +70	°C
Storage Temperature	T _{stg}	-40 ~ +125	°C

Block Diagram

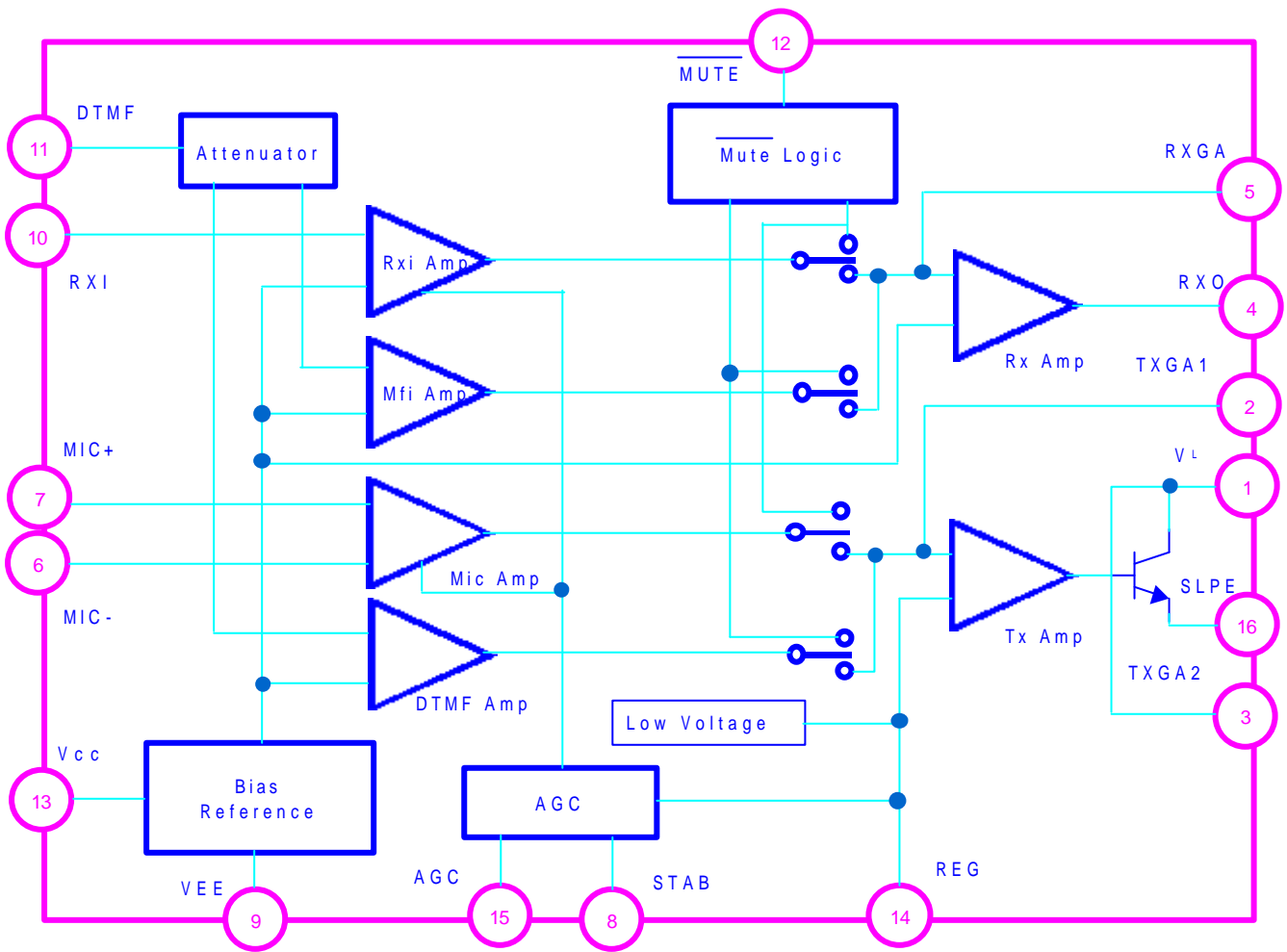

Pin Description

Pin No.	Symbol	Description
1	VL	Positive power line and TX Amp output
2	TXGA1	TX gain adjustment
3	TXGA2	TX gain adjustment
4	RXO	RX output
5	RXGA	RX gain adjustment
6	MIC ⁻	MIC(-) input
7	MIC ⁺	MIC(+) input
8	SRAB	Current stabilizer
9	V _{EE}	Ground
10	RXI	Rx input
11	DTMF	DTMF signal input
12	$\overline{\text{MUTE}}$	'H' Mute input
13	V _{CC}	Internal power supply pin
14	REG	Voltage regulator decoupling
15	AGC	Automation gain control input
16	SLPE	Slope(DC resistance) adjustment

Electrical Characteristics

Characteristics	Symbol	Test Condition	Min.	Typ.	Max.	Unit	
Line Voltage	V _L	I _{Line} = 1mA	-	1.6	-	V	
		I _{Line} = 4mA	-	1.9	-		
		I _{Line} = 15mA	3.55	4	4.25		
		I _{Line} = 100mA	4.9	5.7	6.5		
		I _{Line} = 140mA	-	-	7.5		
Variation with temperature	V _L / T	I _{Line} = 15mA	-	-0.3	-	mV/k	
Voltage drop over circuit between V _L & V _{EE} with external resistor R _{AV}	R _{VA}	I _{Line} = 15mA R _{VA} (R _{EG} to S _{LPE}) = 39K	-	4.5	-	V	
		I _{Line} = 15mA R _{VA} (V _L to R _{EG}) = 68K	-	3.5	-	V	
Supply Voltage	V _{CC}	$\overline{\text{Mute}}$ =High	I _p =1.2mA	2.2	2.7	-	V
			I _p =0mA	-	3.4	-	
MIC input impedance	Zi(mic)	Between MIC ⁻ & MIC ⁺	-	64	-	k	
		MIC ⁻ or MIC ⁺ to V ⁻	-	32	-		

Electrical Characteristics (continued)

Characteristics	Symbol	Test Conditions	Min.	Typ.	Max.	Unit	
Common mode Rejection Ratio	CMRR(Tx)	-	-	82	-	dB	
TX Gain	Gv(Tx)	R7=68K, Vin=3mVrms	50.5	52	53.5	dB	
TX Gain frequency Response	G _{TXF}	f=300 ~ 3400Hz	-	± 0.2	-	dB	
DTMF input impedance	Z _{i(MF)}	-	-	20.7	-	k	
DTMF Gain	G _{V(MF)}	R7=68K, DTMF mode	24	25.5	27	dB	
DTMF Gain Response	G _{MF}	R7=68K, f=300~3400Hz	-	± 0.2	± 0.5	dB	
TX Gain Adjustment	Gv.adj(Tx)	R7 = 68k →25k	-12	-8	-7	dB	
TX Dynamic output Voltage	T _o (Tx)	THD=10%	IL=4mA	-	0.8	-	Vrms
			IL=15mA	1.7	2.3	-	
TX noise output Voltage	Vno(Tx)	R7=68K Between pin6 & pin7=200	-	-69	-	dBmp	
RX input impedance	Zi(Rx)	-	-	21	-	K	
RX output impedance	Zo(Rx)	-	-	4	-	K	
RX Gain	Gv(Rx)	R4=100k, RL=300	29.5	31	32.5	dB	
RX Gain Frequency Response	G _{TXF}	f=300 ~ 3400Hz	-	± 0.2	-	dB	
RX Dynamic output voltage	V _o (Rx)	THD=2% R4=100K	RL=150	0.22	0.33	-	V
			RL=450	0.3	0.48	-	
RX noise output voltage	Vno(Rx)	R _L = 300 R4=100 K IL= 15mA, Rxi=open	-	50	-	μV	
RX Gain adjustment	Gv.adj(Rx)	R4=100K → 28K	-13	-11	-9	dB	
Mute input voltage	V _{IH} (Mute)	-	1.5	-	V _{CC}	V	
	V _{IL} (Mute)	-	-	-	0.3		
Mute input current	I _{Mute}	-	-	8	15	μA	
Mute Attenuation	Matt(TX)	MIC+ or MIC- to V _L (CCIT weighted)	-	70	-	dB	
DTMF Gain	Gv(DTMF)	voltage gain from DTMF to Rxo	-	-19	-	dB	
TX Gain variation range By AGC	G _{TXA}	R6 = 110k IL=15mA ~ 70mA	-	-5.8	-	dB	
RX Gain variation range By AGC	G _{RXA}	R6=110k IL=15mA ~ 70mA	-	-5.8	-	dB	
Highest line current for maximum gain	I _{HL} (AGC)	R6=110k	17	23	26	mA	
Lowest line current for minimum gain	I _{LL} (AGC)	R6=110k	54	61	73	mA	

Typical Performance Characteristics

V_{LN}, V_{CC} vs LINE CURRENT

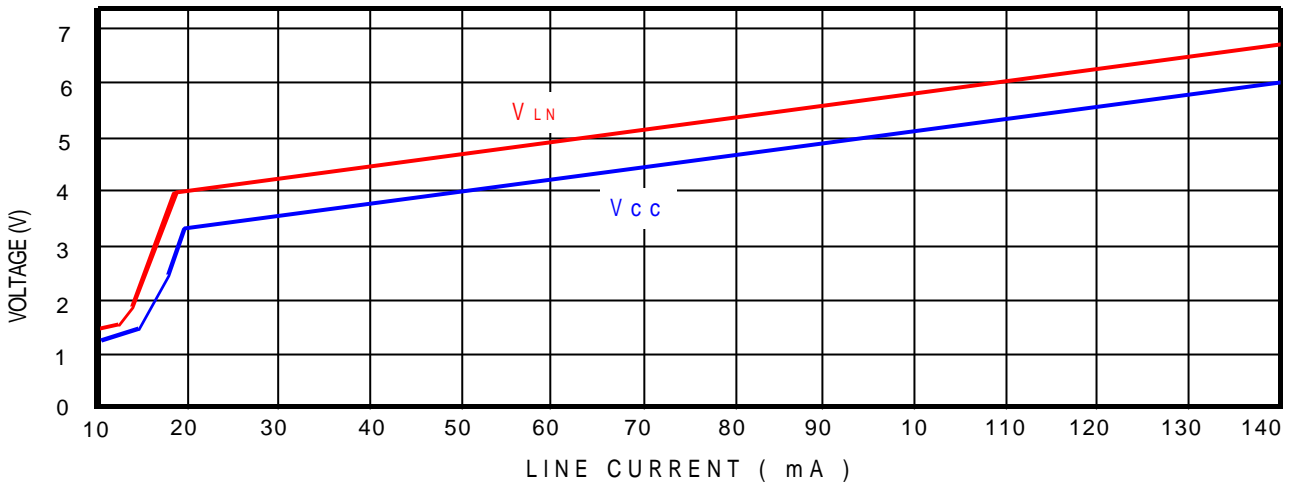

TRANSMIT GAIN vs LINE CURRENT

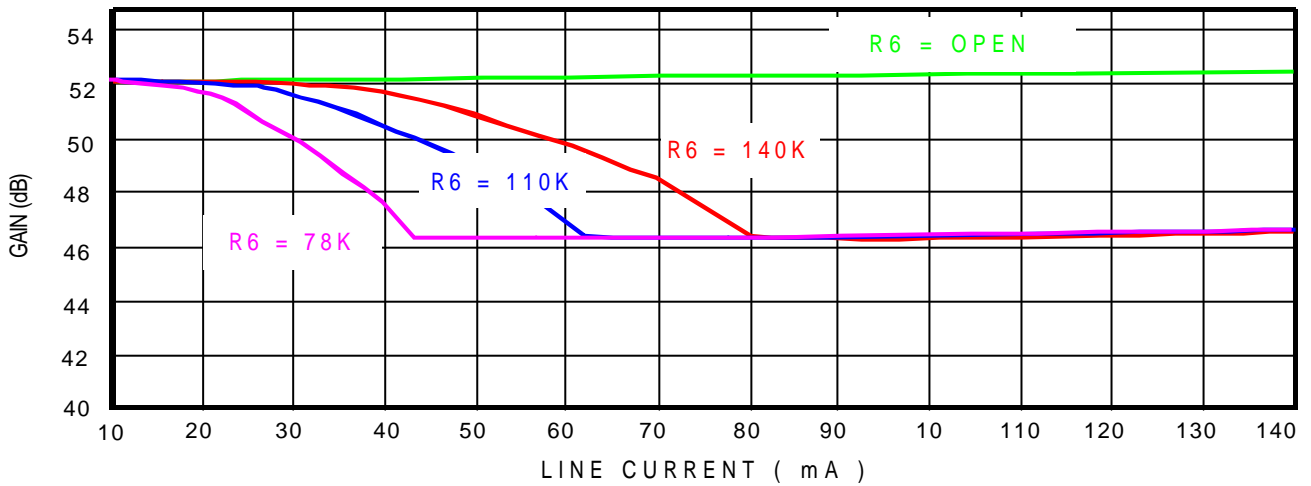

RECEIVE GAIN vs LINE CURRENT

