



**W83194BR-P4X
STEPLESS VIA P4X/P4M MAIN
CLOCK GENERATOR**

Date: 02/21/2003 Revision: 2.0

W83194BR-P4X Data Sheet Revision History

NO.	Pages	Dates	Version	Web Version	Main Contents
1	n.a.			n.a.	All of the versions before 0.50 are for internal use.
2	n.a.	7/01/2002	1.0	n.a	Change version and version on web site to 1.0
3	4,10	8/07/2002	1.1	1.1	FS1 internal 120K pull up change to pull down. Register 3: bit 0,1 PCISTOPB read back & CPUSTOPB read back exchange. Change version and version on web site to 1.1
4	5	9/19/2002	1.2	1.2	VTPWGD# This pin is LOW active.
5	All	2/21/2003	2.0	2.0	Update new form
6					
7					
8					
9					
10					

Please note that all data and specifications are subject to change without notice. All the trademarks of products and companies mentioned in this data sheet belong to their respective owners.

LIFE SUPPORT APPLICATIONS

These products are not designed for use in life support appliances, devices, or systems where malfunction of these products can reasonably be expected to result in personal injury. Winbond customers using or selling these products for use in such applications do so at their own risk and agree to fully indemnify Winbond for any damages resulting from such improper use or sales.

STEPLESS CLOCK FOR VIA P4 CHIPSET**TABLE OF CONTENT**

1. GENERAL DESCRIPTION	1
2. PRODUCT FEATURES	1
3. BLOCK DIAGRAM	2
4. PIN CONFIGURATION	2
5. PIN DESCRIPTION.....	3
5.1 CRYSTAL I/O	3
5.2 CPU, AGP, AND PCI, IOAPIC CLOCK OUTPUTS	3
5.3 I ² C CONTROL INTERFACE	4
5.4 FIXED FREQUENCY OUTPUTS	4
5.5 POWER MANAGEMENT PINS.....	4
5.6 POWER PINS.....	5
5.7 HARDWARE MULTSEL [1:0] SELECTS FUNCTION.....	5
6. FREQUENCY SELECTION BY HARDWARE OR SOFTWARE	6
7. I²C CONTROL AND STATUS REGISTERS.....	7
7.1 REGISTER 0: FREQUENCY SELECT REGISTER (DEFAULT = 0).....	7
7.2 REGISTER 1: CPU CLOCK REGISTER (1 = ENABLE, 0 = STOPPED)	7
7.3 REGISTER 2: PCI CLOCK REGISTER (1 = ENABLE, 0 = STOPPED)	7
7.4 REGISTER 3: PCI, REF, 48MHZ CLOCK REGISTER (1 = ENABLE, 0 = STOPPED)	8
7.5 REGISTER 4: MULTISEL1 IOAPIC, AGP CONTROL REGISTER (1 = ENABLE, 0 = STOPPED) ..	8
7.6 REGISTER 5: WATCHDOG CONTROL REGISTER	9
7.7 THE REGISTER 6, 7 IS RESERVED FOR BUFFER.....	9
7.8 REGISTER 8: WATCHDOG TIMER REGISTER	9
7.9 REGISTER 9: M/N PROGRAM REGISTER.....	9
7.10 REGISTER 10: M/N PROGRAM REGISTER.....	10
7.11 REGISTER 11: SPREAD SPECTRUM PROGRAMMING REGISTER	10
7.12 REGISTER 12: DIVISOR AND STEP-LESS ENABLE CONTROL REGISTER.....	10
7.13 REGISTER 13: CPU TO IOAPIC SKEW CONTROL.....	12
7.14 REGISTER 14: CPU TO PCI AND IOAPIC SKEW CONTROL.....	12
7.15 REGISTER 15: SEL24_48 AND CPU TO CPUCS SKEW CONTROL	12
7.16 REGISTER 16: RESERVED	13
7.17 REGISTER 17: RESERVED	13
7.18 REGISTER 18: RESERVED	13
7.19 REGISTER 19: WINBOND CHIP ID REGISTER (READ ONLY).....	14
7.20 REGISTER 20: WINBOND CHIP ID REGISTER (READ ONLY).....	14
8.ACCESS INTERFACE.....	15

STEPLESS CLOCK FOR VIA P4 CHIPSET

8.1 BLOCK WRITE PROTOCOL.....	15
8.2 BLOCK READ PROTOCOL.....	15
8.3 BYTE WRITE PROTOCOL.....	15
8.4 BYTE READ PROTOCOL.....	15
9. SPECIFICATIONS.....	16
9.1 ABSOLUTE MAXIMUM RATINGS.....	16
10. ORDERING INFORMATION.....	16
11. HOW TO READ THE TOP MARKING.....	16
12. PACKAGE DRAWING AND DIMENSIONS.....	17

STEPLESS CLOCK FOR VIA P4 CHIPSET

1. GENERAL DESCRIPTION

The W83194BR-P4X is a Clock Synthesizer for VIA P4 chipset. W83194BR-P4X provides all clocks required for high-speed microprocessor and provides step-less frequency programming and 32 different frequencies of CPU, PCI, and AGP clocks setting. All clocks are externally selectable with smooth transitions.

The W83194BR-P4X provides I²C serial bus interface to program the registers to enable or disable each clock outputs and provides -0.5% and +/-0.25% center type spread spectrum or programmable S.S.T. scale to reduce EMI.

The W83194BR-P4X also has watch dog timer and reset output pin to support auto-reset when systems hanging caused by improper frequency setting.

The W83194BR-P4X accepts a 14.318 MHz reference crystal as its input and runs on a 3.3V supply. High drive PCI CLOCK outputs typically provide greater than 1 V /ns slew rate into 30 pF loads. The fixed frequency outputs as REF and 48 MHz provide better than 0.5V /ns slew rate.

2. PRODUCT FEATURES

- 2 Differential pairs of CPU clock outputs
- 1 Differential pairs push pull of CPU_CS clock outputs
- 3 AGP clock outputs
- 9 PCI synchronous clocks
- 24_48Mhz clock output for super I/O.
- 48 MHz clock output for USB.
- 2 IOAPIC clock outputs.
- 1 REF clock output.
- Skew form CPU to PCI clock 1 to 4 ns, center 2.6 ns
- Smooth frequency switch with selections from 66.8 to 200MHz
- Step-less frequency programming
- I²C 2-Wire serial interface and support byte read/write and block read/write.
- -0.5% and +/- 0.25% center type spread spectrum
- Programmable S.S.T. scale to reduce EMI
- Programmable registers to enable/stop each output and select modes
- Watch Dog Timer and RESET# output pins
- 48-pin SSOP package

STEPLESS CLOCK FOR VIA P4 CHIPSET

3. BLOCK DIAGRAM

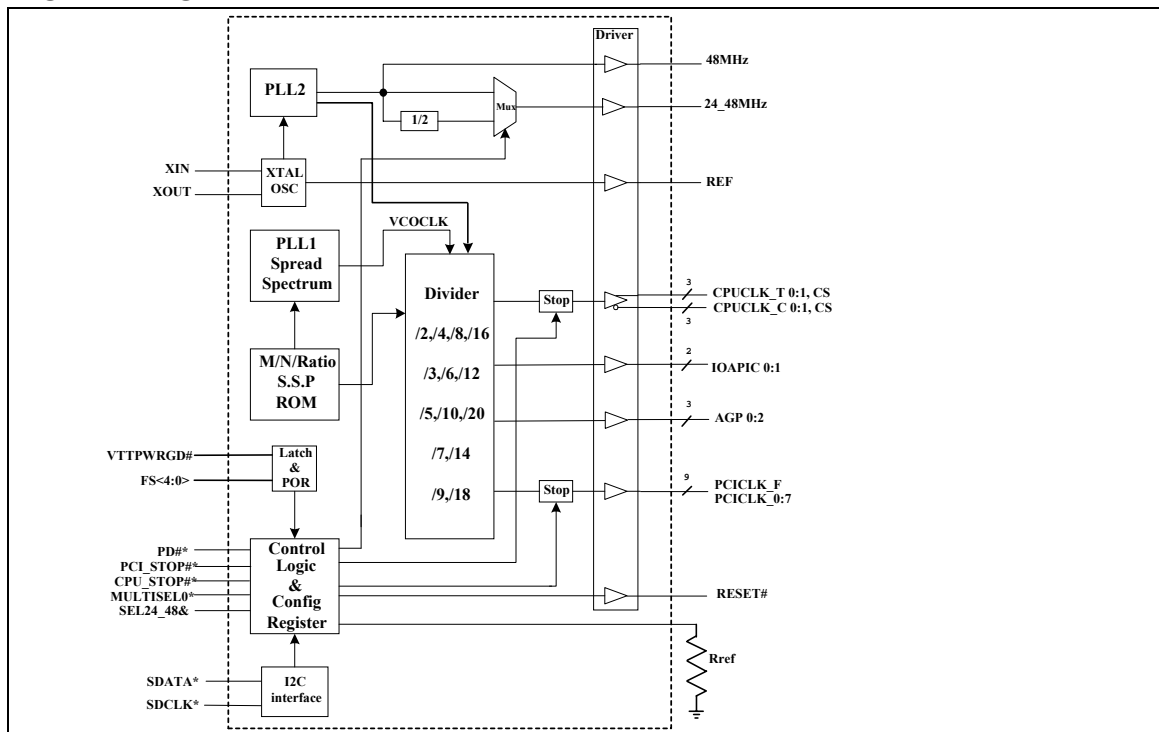

4. PIN CONFIGURATION

SEL24_48&/REF	1	48	VDDAPIC (2.5V)
VDDREF	2	47	GND
GND	3	46	IOAPIC0
XIN	4	45	IOAPIC1
XOUT	5	44	GND
VDD48	6	43	VDDCPU (2.5V)
FS3&/48MHz	7	42	CPUCLKT_CS
FS2&/24_48MHz	8	41	CPUCLKC_CS
GND	9	40	CPUCLK_T0
FS0*/PCICLK_F	10	39	CPUCLK_C0
FS1&/PCICLK0	11	38	VDDCPU (3.3V)
MULTISEL0*/PCICLK1	12	37	IREF
GND	13	36	GND
PCICLK2	14	35	CPUCLK_T1
PCICLK3	15	34	CPUCLK_C1
VDDPCI	16	33	VTTWPGD#
PCICLK4	17	32	CPU_STOP#*
PCICLK5	18	31	PCI_STOP#*
PCICLK6	19	30	RESET#
GND	20	29	SDATA*
PCICLK7	21	28	SDCLK*
PD#*	22	27	AGP2
AGP0	23	26	AGP1
VDDAGP	24	25	GND

#: Active low

^: These outputs have 1.5 ~ 2X drive strength

*: Internal pull up resistor 120K to VDD

&: Internal Pull-down resistor 120K to GND

STEPLESS CLOCK FOR VIA P4 CHIPSET

5. PIN DESCRIPTION

Buffer type symbol	Description
IN	Input
IN _{tp120k}	Latched input at power up, internal 120kΩ pull up.
IN _{td120k}	Latched input at power up, internal 120kΩ pull down.
OUT	Output
OD	Open Drain
I/O	Bi-directional Pin
I/OD	Bi-directional Pin, Open Drain.
#	Active Low
*	Internal 120kΩ pull-up
&	Internal 120 kΩ pull-down

5.1 Crystal I/O

PIN	Pin Name	Type	Description
4	XIN	IN	Crystal input with internal loading capacitors (18pF) and feedback resistors.
5	XOUT	OUT	Crystal output at 14.318MHz nominally with internal loading capacitors (18pF).

5.2 CPU, AGP, and PCI, IOAPIC Clock Outputs

PIN	Pin Name	Type	Description
34,35,39,40	CPUCLK_T [0:1] CPUCLK_C [0:1]	OUT	Low skew (< 250ps) differential clock outputs for host frequencies of CPU
41,42	CPUCLKT_CS CPUCLKC_CS	OUT	Low skew (< 250ps) differential push pull clock outputs for host frequencies of CHIPSET
23,26,27	AGP0: 2	OUT	3.3V AGP clock outputs.
10	PCICLK_F	OUT	3.3V free running PCI clock output.
	FS0*	IN _{tp120k}	Latched input for FS0 at initial power up for H/W selecting the output frequency. This is internal 120K pull up.
11	PCICLK0	OUT	3.3V PCI clock output.
	FS1&	IN _{td120k}	Latched input for FS1 at initial power up for H/W selecting the output frequency, This is internal 120K pull down.
12	PCICLK1	OUT	3.3V PCI clock output.
	MULTI_SEL0*	IN _{tp120k}	Latched input for MULTSEL0 at initial power up, internal 120K pull up
14,15,17,18, 19,21	PCICLK [2:7]	OUT	Low skew (< 250ps) PCI clock outputs.
45,46	IOAPIC0: 1	OUT	2.5V PCI/2 clock outputs.

STEPLESS CLOCK FOR VIA P4 CHIPSET

5.3 I²C Control Interface

PIN	Pin Name	Type	Description
25	SDATA*	I/OD	Serial data of I ² C 2-wire control interface with internal pull-up resistor.
26	SDCLK*	IN	Serial clock of I ² C 2-wire control interface with internal pull-up resistor.

5.4 Fixed Frequency Outputs

PIN	Pin Name	Type	Description
1	REF	OUT	14.318MHz output.
	SEL24_48&	IN _{td120k}	Latched input for 24MHz or 48MHz select pin. This is internal 120K pull down default 24MHz. In power on reset period, it is a hardware-latched pin, and it can be R/W by I2C control after power on reset period. Select by register 16 bit 6.
7	48MHz	OUT	48MHz clock output for USB.
	FS3&	IN _{td120k}	Latched input for FS3 at initial power up for H/W selecting the output frequency. This is internal 120K pull down.
8	24_48MHz	OUT	24(default) or 48MHz clock output, In power on reset period, it is a hardware-latched pin, and it can be R/W by I2C control after power on reset period. Select by register 16 bit 7.
	FS2&	IN _{td120k}	Latched input for FS2 at initial power up for H/W selecting the output frequency. This is internal 120K pull down.

5.5 Power Management Pins

PIN	Pin Name	Type	Description
33	VTPWGD#	IN	Power good input signal comes from ACPI with LOW active. This 3.3V input is level sensitive strobe used to determine FS [4:0] and MULTISEL input are valid and is ready to sample. This pin is LOW active.
32	CPU_STOP#*	IN	CPU clock stop control pin, This pin is low active. Internal 120kΩ pull-up.
31	PCI_STOP#*	IN	PCI clock stop control pin, This pin is low active. Internal 120kΩ pull-up.
37	IREF	IN	Deciding the reference current for the CPUCLK pairs. The pin was connected to the precision resistor tied to ground to decide the appropriate current. There are several modes to select different current via power on trapping the Pin 12 (MULTISEL). The table is show as follows.
30	RESET#	OD	System reset signal when the watchdog is time out. This pin will generate 250ms low phase when the watchdog timer is timeout.
22	PD#*	IN	Power Down Function. This is power down pin, low active (PD#). Internal 120K pull up

STEPLESS CLOCK FOR VIA P4 CHIPSET

5.6 Power Pins

PIN	Pin Name	Type	Description
2	VDDREF	PWR	3.3V power supply for REF.
16	VDDPCI	PWR	3.3V power supply for PCI.
24	VDDAGP	PWR	3.3V power supply for AGP.
38	VDDCPU	PWR	3.3V power supply for CPU.
43	VDDCPU_CS	PWR	2.5V power supply for CPUCLKT & C_CS.
48	VDDAPIC	PWR	2.5V power supply for IOAPIC.
6	VDD48	PWR	Analog power 3.3V for 48MHz.
3,9,13,20,25, 36,44,47	GND	PWR	Ground pin for 3.3 V

5.7 Hardware MULTSEL [1:0] selects Function

Multsel1	Multsel0	Board Target trace/Term Z	Reference R, IREF = Add/(3*Rr)	Output Current	Voh @ Z
0	0	50 Ω	Rr =221 1% IREF = 5.00mA	Ioh=4*IREF	1.0V @ 50
0	0	60 Ω	Rr =221 1% IREF = 5.00mA	Ioh=4*IREF	1.2V @ 60
0	1	50 Ω	Rr =221 1% IREF = 5.00mA	Ioh=5*IREF	1.25V @ 50
0	1	60 Ω	Rr =221 1% IREF = 5.00mA	Ioh=5*IREF	1.5V @ 60
1	0	50 Ω	Rr =221 1% IREF = 5.00mA	Ioh=6*IREF	1.5V @ 50
1	0	60 Ω	Rr =221 1% IREF = 5.00mA	Ioh=6*IREF	1.8V @ 60
1	1	50 Ω	Rr =221 1% IREF = 5.00mA	Ioh=7*IREF	1.75V @ 50
1	1	60 Ω	Rr =221 1% IREF = 5.00mA	Ioh=7*IREF	2.1V @ 50
0	0	50 Ω	Rr =475 1% IREF = 2.32mA	Ioh=4*IREF	0.47V @ 50
0	0	60 Ω	Rr =475 1% IREF = 2.32mA	Ioh=4*IREF	0.56V @ 50
0	1	50 Ω	Rr =475 1% IREF = 2.32mA	Ioh=5*IREF	0.58V @ 50
0	1	60 Ω	Rr =475 1% IREF = 2.32mA	Ioh=5*IREF	0.7V @ 60
1	0	50 Ω	Rr =475 1% IREF = 2.32mA	Ioh=6*IREF	0.7V @ 50
1	0	60 Ω	Rr =475 1% IREF = 2.32mA	Ioh=6*IREF	0.84V @ 60
1	1	50 Ω	Rr =475 1% IREF = 2.32mA	Ioh=7*IREF	0.81V @ 50
1	0	60 Ω	Rr =475 1% IREF = 2.32mA	Ioh=6*IREF	0.97V @ 60

STEPLESS CLOCK FOR VIA P4 CHIPSET

6. FREQUENCY SELECTION BY HARDWARE OR SOFTWARE

This frequency table is used at power on latched FS [4:0] value or software programming at SSEL [4:0] (Register 0 bit 6 ~ 2).

FS4	FS3	FS2	FS1	FS0	CPU (MHZ)	AGP (MHZ)	PCI (MHZ)	IOAPIC (MHz)	Spread %
0	0	0	0	0	66.7	66.66	33.33	16.665	+/-0.25%
0	0	0	0	1	100.0	66.67	33.335	16.668	+/-0.25%
0	0	0	1	0	133.3	66.67	33.335	16.668	+/-0.25%
0	0	0	1	1	200.0	66.66	33.33	16.665	+/-0.25%
0	0	1	0	0	100.9	67.27	33.635	16.818	+/-0.25%
0	0	1	0	1	103.0	68.67	34.335	17.168	+/-0.25%
0	0	1	1	0	107.0	71.33	35.665	17.833	+/-0.25%
0	0	1	1	1	110.0	73.33	36.665	18.333	+/-0.25%
0	1	0	0	0	133.9	66.95	33.475	16.738	+/-0.25%
0	1	0	0	1	137.3	68.66	34.33	17.165	+/-0.25%
0	1	0	1	0	140.0	70	35	17.5	+/-0.25%
0	1	0	1	1	142.7	71.33	35.665	17.833	+/-0.25%
0	1	1	0	0	145.3	72.66	36.33	18.165	+/-0.25%
0	1	1	0	1	146.7	73.33	36.665	18.333	+/-0.25%
0	1	1	1	0	153.3	76.66	38.33	19.165	+/-0.25%
0	1	1	1	1	160.0	80	40	20	+/-0.25%
1	0	0	0	0	66.7	66.66	33.33	16.665	-0.5%
1	0	0	0	1	100.0	66.67	33.335	16.668	-0.5%
1	0	0	1	0	133.3	66.67	33.335	16.668	-0.5%
1	0	0	1	1	200.0	66.66	33.33	16.665	-0.5%
1	0	1	0	0	66.7	66.66	33.33	16.665	+/-0.25%
1	0	1	0	1	100.0	66.67	33.335	16.668	+/-0.25%
1	0	1	1	0	133.3	66.67	33.335	16.668	+/-0.25%
1	0	1	1	1	200.0	66.66	33.33	16.665	+/-0.25%
1	1	0	0	0	201.0	67	33.5	16.75	+/-0.25%
1	1	0	0	1	203.0	67.67	33.835	16.918	+/-0.25%
1	1	0	1	0	205.0	68.33	34.165	17.083	+/-0.25%
1	1	0	1	1	207.0	69	34.5	17.25	+/-0.25%
1	1	1	0	0	209.0	69.67	34.835	17.418	+/-0.25%
1	1	1	0	1	211.0	70.33	35.165	17.583	+/-0.25%
1	1	1	1	0	213.0	71	35.5	17.75	+/-0.25%
1	1	1	1	1	215.0	71.67	35.835	17.918	+/-0.25%

STEPLESS CLOCK FOR VIA P4 CHIPSET
7. I²C CONTROL AND STATUS REGISTERS
7.1 Register 0: Frequency Select Register (default = 0)

Bit	Name	PWD	Description
7	SSEL [3]	0	Frequency selection by software via I ² C
6	SSEL [2]	0	
5	SSEL [1]	0	
4	SSEL [0]	0	
3	EN_SSEL	0	Enable software program FS [4:0]. 0 = Select frequency by hardware. 1 = Select frequency by software I ² C - Bit 7~ 4,2.
2	SSEL [4]	0	Frequency selection bit 4
1	EN_SPSP	0	Enable Spread Spectrum in the frequency table. 0 = Normal 1 = Spread Spectrum enabled
0	EN_SAFE_FREQ	0	Enable reload safe frequency when the watchdog is timeout. 0 = reload the FS [4:0] latched pins when watchdog time out. 1 = reload the safe frequency bit defined at Register 5 bit 4~0.

7.2 Register 1: CPU Clock Register (1 = enable, 0 = Stopped)

Bit	Pin NO	PWD	Description
7	42,41	1	CPUCLK_T / C_CS
6	35,34	1	CPUCLK_T1 / C1
5	40,39	1	CPUCLK_T0 / C0
4	-	X	FS [4] Read back.
3	-	X	FS [3] Read back
2	-	X	FS [2] Read back
1	-	X	FS [1] Read back
0	-	X	FS [0] Read back

7.3 Register 2: PCI Clock Register (1 = enable, 0 = Stopped)

Bit	Pin NO	PWD	Description
7	21	1	PCICLK7
6	19	1	PCICLK6
5	18	1	PCICLK5
4	17	1	PCICLK4
3	15	1	PCICLK3
2	14	1	PCICLK2

STEPLESS CLOCK FOR VIA P4 CHIPSET

1	12	1	PCICLK1
0	11	1	PCICLK0

7.4 Register 3: PCI, REF, 48MHz Clock Register (1 = enable, 0 = Stopped)

Bit	Pin NO	PWD	Description
7	7	1	48MHZ
6	8	1	24_48MHz
5	1	1	REF
4	10	1	PCICLK_F
3	41,42	1	CPUCS Stop control: 0: CPUCLK1 free run 1: CPUCLK1 can stopped by CPU_STOP#
2	8	0	PCI_F Stop control 0: PCI_F free run 1: PCI_F can stopped by PCI_STOP#
1	32	1	PCISTOPB read back
0	31	1	CPUSTOPB read back

7.5 Register 4: MULTISEL1 IOAPIC, AGP Control Register (1 = enable, 0 = Stopped)

Bit	Pin NO	PWD	Description
7	-	0	MULTISEL1 I2C R/W
6	-	1	Reserved
5	-	1	Reserved
4	45	1	IOAPIC1
3	46	1	IOAPIC0
2	27	1	AGP2
1	26	1	AGP1
0	23	1	AGP0

STEPLESS CLOCK FOR VIA P4 CHIPSET

7.6 Register 5: Watchdog Control Register

Bit	Name	PWD	Description
7	MULTISEL0	X	Pin 12 MULTISEL0 power on trapping pin data read back
6	EN_WD	0	Enable Watchdog Timer if set to 1. Set to 0, disable watchdog timer. Read this bit will return a counting state. If timer continues down count, this bit will return 1. Otherwise, this bit will return 0.
5	WD_TIMEOUT	0	Watchdog Timeout Status. If the watchdog is started and timer down counts to zero, this bit will be set to 1. Clear this bit to logic 0, If set to 1, when the watchdog is restart in the next time. This bit is Read Only.
4	SAF_FREQ [4]	0	Watchdog safe frequency bits. These bits will be reloaded into FS [4:0], if the watchdog is timeout and enable reload safe frequency bits.
3	SAF_FREQ [3]	0	
2	SAF_FREQ [2]	0	
1	SAF_FREQ [1]	0	
0	SAF_FREQ [0]	0	

7.7 The Register 6, 7 is reserved for Buffer

7.8 Register 8: Watchdog Timer Register

Bit	Name	PWD	Description
7	WD_TIME [7]	0	Watchdog timeout time. The bit resolution is 250mS. The default time is $8 \times 250\text{mS} = 2.0$ seconds. If the watchdog timer is start, this register will be down count. Read this register will return a down count value.
6	WD_TIME [6]	0	
5	WD_TIME [5]	0	
4	WD_TIME [4]	0	
3	WD_TIME [3]	1	
2	WD_TIME [2]	0	
1	WD_TIME [1]	0	
0	WD_TIME [0]	0	

7.9 Register 9: M/N Program Register

Bit	Name	PWD	Description
7	N_DIV [8]	1	Programmable N divisor value. Bit 7 ~0 are defined in the Register 10.
6	TEST2	0	Test bit 2. Winbond test bit, do not change them.
5	TEST1	1	Test bit 1. Winbond test bit, do not change them.
4	M_DIV [4]	0	Programmable M divisor value.
3	M_DIV [3]	1	
2	M_DIV [2]	1	
1	M_DIV [1]	0	
0	M_DIV [0]	1	

STEPLESS CLOCK FOR VIA P4 CHIPSET

7.10 Register 10: M/N Program Register

Bit	Name	PWD	Description
7	N_DIV [7]	0	Programmable N divisor value bit 7 ~0. The bit 8 is defined in Register 9.
6	N_DIV [6]	1	
5	N_DIV [5]	1	
4	N_DIV [4]	0	
3	N_DIV [3]	0	
2	N_DIV [2]	1	
1	N_DIV [1]	1	
0	N_DIV [0]	1	

7.11 Register 11: Spread Spectrum Programming Register

Bit	Name	PWD	Description
7	SP_UP [3]	0	Spread Spectrum Up Counter bit 3.
6	SP_UP [2]	0	Spread Spectrum Up Counter bit 2.
5	SP_UP [1]	0	Spread Spectrum Up Counter bit 1.
4	SP_UP [0]	1	Spread Spectrum Up Counter bit 0
3	SP_DOWN [3]	1	Spread Spectrum Down Counter bit 3
2	SP_DOWN [2]	1	Spread Spectrum Down Counter bit 2
1	SP_DOWN [1]	1	Spread Spectrum Down Counter bit 1
0	SP_DOWN [0]	1	Spread Spectrum Down Counter bit 0

7.12 Register 12: Divisor and Step-less Enable Control Register

Bit	Name	PWD	Description
7	EN_MN_PROG	0	0: use frequency table 1: use M/N register to program frequency The equation is $VCO\ freq. = 14.318MHz * (N+4) / M$. When the watchdog timer is timeout, this will be clear. In this time, the frequency is set to hardware default latched or safe frequency set by EN_SFAE_FREQ (Register 0 bit 0).
6	RATIO_SEL [4]	0	CPU, PCI, AGP, ratio selection. The ratio is shown as following table.
5	RATIO_SEL [3]	0	
4	RATIO_SEL [2]	0	
3	RATIO_SEL [1]	1	
2	RATIO_SEL [0]	0	
1	TEST0	0	Test bit 0. Winbond test bit, do not change them.
0	Reserved	0	

STEPLESS CLOCK FOR VIA P4 CHIPSET

I2C Reg12 Definition

Reg12 Bit6	Reg12 Bit5	Reg12 Bit4	Reg12 Bit3	Reg12 Bit2	CPU ratio	CPU_CS ratio	IOAPIC ratio	AGP ratio	PCI ratio
SSEL4	SSEL3	SSEL2	SSEL1	SSEL0					
0	0	0	0	0	2	2	24	6	12
0	0	0	0	1	3	3	24	6	12
0	0	0	1	0	4	4	24	6	12
0	0	0	1	1	6	6	24	6	12
0	0	1	0	0	4	4	24	6	12
0	0	1	0	1	4	4	24	6	12
0	0	1	1	0	4	4	24	6	12
0	0	1	1	1	4	4	24	6	12
0	1	0	0	0	4	4	24	6	12
0	1	0	0	1	5	5	16	8	16
0	1	0	1	0	5	5	16	8	16
0	1	0	1	1	5	5	24	6	12
0	1	1	0	0	5	5	24	6	12
0	1	1	0	1	5	5	16	8	16
0	1	1	1	0	5	5	20	10	20
0	1	1	1	1	5	5	16	8	16
1	0	0	0	0	5	5	20	10	20
1	0	0	0	1	5	5	20	10	20
1	0	0	1	0	6	6	20	10	20
1	0	0	1	1	6	6	24	6	12
1	0	1	0	0	6	6	16	8	16
1	0	1	0	1	6	6	14	7	14
1	0	1	1	0	6	6	18	9	18
1	0	1	1	1	6	6	14	12	14
1	1	0	0	0	2	2	16	8	16
1	1	0	0	1	3	3	24	12	24
1	1	0	1	0	4	4	16	8	16
1	1	0	1	1	6	6	16	8	16
1	1	1	0	0	2	2	14	7	14
1	1	1	0	1	2	2	18	9	18
1	1	1	1	0	4	4	14	7	14
1	1	1	1	1	4	4	18	9	18

STEPLESS CLOCK FOR VIA P4 CHIPSET
7.13 Register 13: CPU to IOAPIC SKEW CONTROL

Bit	Name	PWD	Description
7	CPU_IOAPIC_SKEW [2]	1	CPU to IOAPIC SKEW control
6	Reserved	0	Reserved
5	Reserved	1	Reserved for Winbond internal use, do not change them
4	Reserved	0	
3	Reserved	0	
2	Reserved	1	
1	Reserved	1	
0	Reserved	1	

7.14 Register 14: CPU to PCI and IOAPIC Skew Control

Bit	Name	PWD	Description
7	CPU_PCI_SKEW [2]	1	CPU to PCI skew
6	CPU_PCI_SKEW [1]	0	
5	CPU_PCI_SKEW [0]	0	
4	CPU_AGP_SKEW [2]	1	CPU to AGP Skew
3	CPU_AGP_SKEW [1]	0	
2	CPU_AGP_SKEW [0]	0	
1	CPU_IOAPIC_SKEW [1]	0	CPU to IOAPIC SKEW control
0	CPU_IOAPIC_SKEW [0]	0	

7.15 Register 15: SEL24_48 and CPU to CPUCS skew Control

Bit	Name	PWD	Description
7	SEL24_48	X	In power on reset period, it is a hardware-latched pin, and it can be R/W by I2C control after power on reset period. 0-> 24 MHz, 1->48MHz. Default is 24Mhz
6	Reserved	0	Reserved
5	Reserved	0	Reserved for Winbond internal use, do not change them
4	Reserved	0	Reserved for Winbond internal use, do not change them
3	Reserved	0	
2	CPU_CPUCS_SKEW [2]	1	CPU to CPUCS Skew
1	CPU_CPUCS_SKEW [1]	0	
0	CPU_CPUCS_SKEW [0]	0	

STEPLESS CLOCK FOR VIA P4 CHIPSET
7.16 Register 16: Reserved

Bit	Name	PWD	Description
7	Reserved	1	Reserved for Winbond internal use, do not change them
6	Reserved	1	
5	Reserved	1	
4	Reserved	1	
3	Reserved	1	Reserved for Winbond internal use, do not change them
2	Reserved	1	
1	Reserved	1	Reserved for Winbond internal use, do not change them
0	Reserved	1	

7.17 Register 17: Reserved

Bit	Name	PWD	Description
7	Reserved	1	Reserved for Winbond internal use, do not change them
6	Reserved	1	
5	Reserved	1	
4	Reserved	1	
3	Reserved	1	Reserved for Winbond internal use, do not change them
2	Reserved	1	
1	Reserved	0	Reserved for Winbond internal use, do not change them
0	Reserved	0	

7.18 Register 18: Reserved

Bit	Name	PWD	Description
7	Reserved	1	Reserved for Winbond internal use, do not change them
6	Reserved	1	
5	Reserved	1	
4	Reserved	1	
3	Reserved	1	Reserved
2	Reserved	1	
1	Reserved	1	Reserved
0	Reserved	1	

STEPLESS CLOCK FOR VIA P4 CHIPSET

7.19 Register 19: Winbond Chip ID Register (Read Only)

Bit	Name	PWD	Description
7	CHPI_ID [7]	0	Winbond Chip ID. W83194BR-P4X is 0x57.
6	CHPI_ID [6]	1	Winbond Chip ID.
5	CHPI_ID [5]	0	Winbond Chip ID.
4	CHPI_ID [4]	1	Winbond Chip ID.
3	CHPI_ID [3]	0	Winbond Chip ID.
2	CHPI_ID [2]	1	Winbond Chip ID.
1	CHPI_ID [1]	1	Winbond Chip ID.
0	CHPI_ID [0]	1	Winbond Chip ID.

7.20 Register 20: Winbond Chip ID Register (Read Only)

Bit	Name	PWD	Description
7	SUB_ID [3]	0	Winbond Sub-Chip ID. The sub-chip ID of W83194BR-P4X is defined as 0010b.
6	SUB_ID [2]	0	Winbond Sub-Chip ID.
5	SUB_ID [1]	0	Winbond Sub-Chip ID.
4	SUB_ID [0]	1	Winbond Sub-Chip ID.
3	VER_ID [3]	0	Winbond Version ID. The Version ID of W83194BR-P4X is 0001b.
2	VER_ID [2]	0	Winbond Version ID.
1	VER_ID [1]	0	Winbond Version ID.
0	VER_ID [0]	1	Winbond Version ID.

STEPLESS CLOCK FOR VIA P4 CHIPSET

8.ACCESS INTERFACE

The W83194BR-P4X provides I²C Serial Bus for microprocessor to read/write internal registers. In the W83194BR-P4X is provided Block Read/Block Write and Byte-Data Read/Write protocol. The I²C address is defined at 0xD2.

Block Read and Block Write Protocol

8.1 Block Write protocol

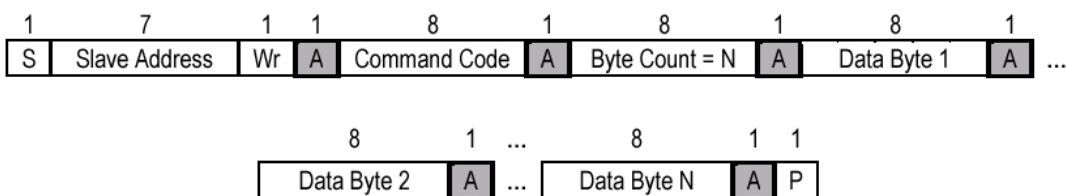

8.2 Block Read protocol

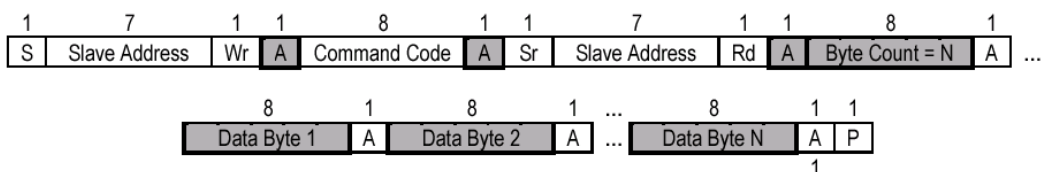

In block mode, the command code must filled 8'h00

8.3 Byte Write protocol

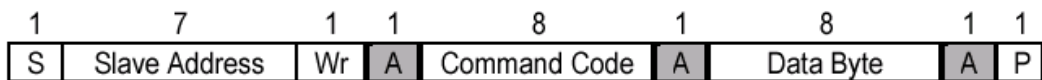

8.4 Byte Read protocol

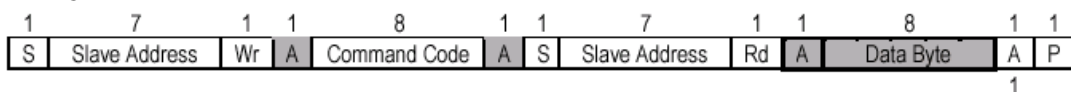

STEPLESS CLOCK FOR VIA P4 CHIPSET

9. SPECIFICATIONS

9.1 ABSOLUTE MAXIMUM RATINGS

Stresses greater than those listed in this table may cause permanent damage to the device. Precautions should be taken to avoid application of any voltage higher than the maximum rated voltages to this circuit. Subjection to maximum conditions for extended periods may affect reliability. Unused inputs must always be tied to an appropriate logic voltage level (Ground or VDD).

Parameter	Rating
Absolute 3.3V Core Supply Voltage	-0.5V to +4.6V
Absolute 3.3V I/O Supply Voltage	- 0.5 V to + 4.6 V
Operating 3.3V Core Supply Voltage	3.135V to 3.465V
Operating 3.3V I/O Supply Voltage	3.135V to 3.465V
Storage Temperature	- 65°C to + 150°C
Ambient Temperature	- 55°C to + 125°C
Operating Temperature	0°C to + 70°C
Input ESD protection (Human body model)	2000V

10. ORDERING INFORMATION

Part Number	Package Type	Production Flow
W83194BR-P4X	48 PIN SSOP	Commercial, 0°C to +70°C

11. HOW TO READ THE TOP MARKING

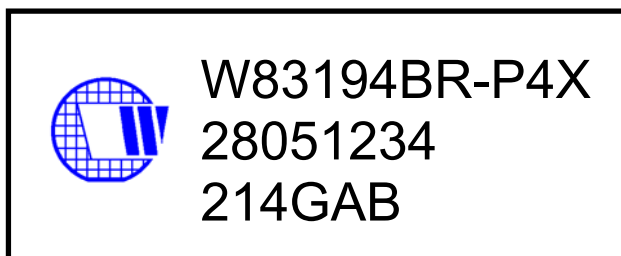

1st line: Winbond logo and the type number: W83194BR-P4X

2nd line: Tracking code 2 8051234

2: wafers manufactured in Winbond FAB 2

8051234: wafer production series lot number

3rd line: Tracking code 814 G B B

214: packages made in '2002, week 14

G: assembly house ID; O means OSE, G means GR

A: Internal use code

B: IC revision

All the trademarks of products and companies mentioned in this data sheet belong to their respective owners.

STEPLESS CLOCK FOR VIA P4 CHIPSET

12. PACKAGE DRAWING AND DIMENSIONS

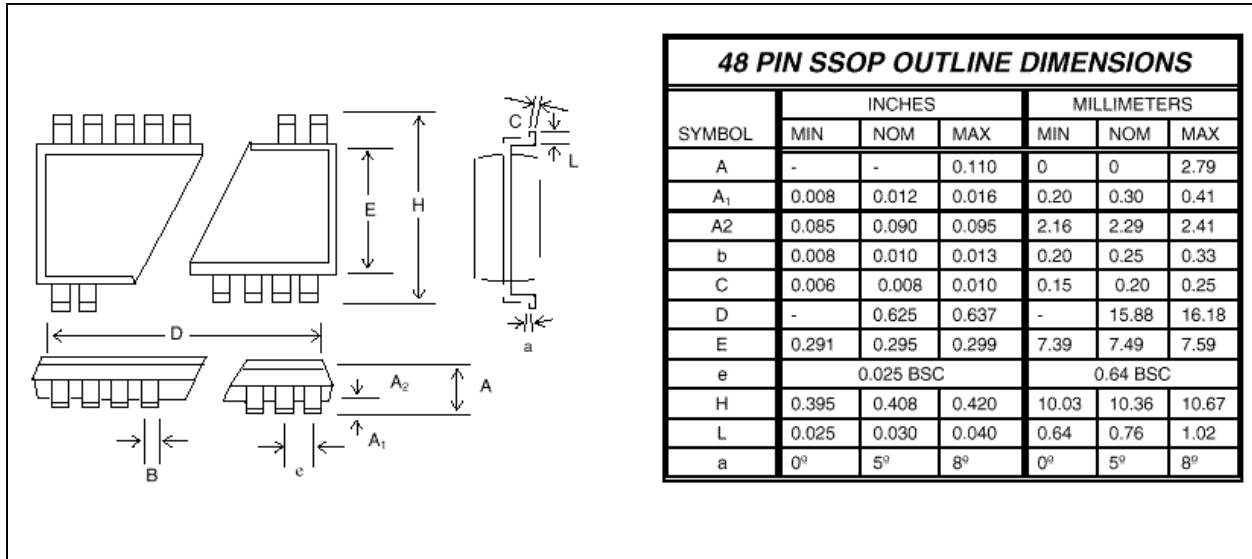

Headquarters

No. 4, Creation Rd. III
Science-Based Industrial Park
Hsinchu, Taiwan
TEL: 886-35-770066
FAX: 886-35-789467
www: <http://www.winbond.com.tw/>

Taipei Office

9F, No. 480, Rueiguang Road, Neihu District,
Taipei, 114, Taiwan
TEL: 886-2-81777168
FAX: 886-2-87153579

Winbond Electronics (H.K.) Ltd.

Rm. 803, World Trade Square, Tower II
123 Hoi Bun Rd., Kwun Tong
Kowloon, Hong Kong
TEL: 852-27516023-7
FAX: 852-27552064

Winbond Electronics

(North America) Corp.
2727 North First Street
San Jose, California 95134
TEL: 1-408-9436666
FAX: 1-408-9436668

Please note that all data and specifications are subject to change without notice. All the trade marks of products and companies mentioned in this data sheet belong to their respective owners.

These products are not designed for use in life support appliances, devices, or systems where malfunction of these products can reasonably be expected to result in personal injury. Winbond customers using or selling these products for use in such applications do so at their own risk and agree to fully indemnify Winbond for any damages resulting from such improper use or sale.