

MF430 ST



ST Assembly

Ordering Information	
PART #	RECEPTACLE
MF430 ST	ST
-40°C to +85°C	

Applications

- Ethernet 10 or 100Mbps
- Token Ring
- Fibre Channel 266Mbps
- Short Wavelength FDDI
- Short Wavelength ATM-SDH/SONET 155Mbps
- Intra-Office Telecom
- General Purpose

Features

- 865nm Surface-Emitting LED
- 250MHz Bandwidth
- Designed for 62.5/125µm Fiber
- Aligned in ST® Receptacle
- MTTF >1,000,000 hours

Description

This high performance LED has been designed for Datacom, Telecom or General Purpose Applications. The short wavelength LED allows cost-effective links over short distances. This very high speed device has an actively aligned receptacle for optimized coupling of power to 62.5/125µm fiber. A Silicon Photodiode is recommended as Receiver for this LED.

MF430 Functional Diagram

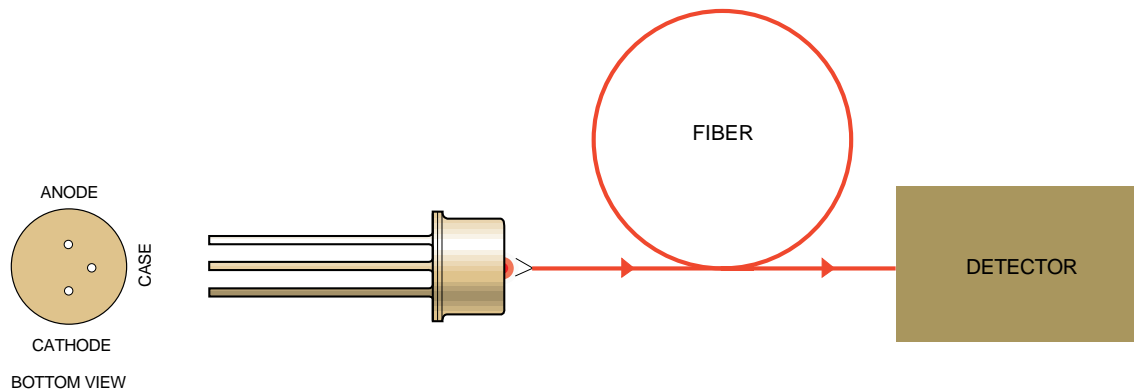

MF430 LED

Absolute Maximum Ratings*

Parameter	Symbol	Min.	Max.	Units
Storage Temperature	T_{stg}	-40	+85	°C
Operating Temperature (Fig 4)	T_{op}	-40	+85	°C
Electrical Power Dissipation (Fig 4)	P_{tot}		250	mW
Continuous Forward Current ($f \leq 10\text{kHz}$)	I_F		110	mA
Peak Forward Current (duty cycle $\leq 50\%$, $f \geq 1\text{MHz}$)	I_{FRM}		180	mA
Reverse Voltage	V_R		1.5	V
Soldering Temperature (Note 1)	T_{sld}		260	°C

*Exceeding these values may cause permanent damage. Functional operation under these conditions is not implied.

Note 1: 2mm from the case for 10s.

Optical & Electrical Characteristics (Case Temperature -25 to +70°C)

Parameter	Symbol	Min.	Typ.	Max.	Units	Test Conditions
Fiber-Coupled-Power (Fig 1, 2, 3)	P_{fiber}	-17.5			dBm	$I_{Peak}=60\text{mA}$ (Note 1,2)
Rise & Fall Time (10-90%, no bias)	t_r, t_f		1.5	2	ns	$I_F=60\text{mA}$ (Note 2)
Bandwidth (3dB _{e1})	f_c		250		MHz	$I_F=60\text{mA}$ (Note 2)
Peak Wavelength	λ_p	850	865	880	nm	$I_F=60\text{mA}$
Spectral Width (FWHM)	$\Delta\lambda$		50	60	nm	$I_F=60\text{mA}$
Forward Voltage (Fig 5)	V_F			2.1	V	$I_F=60\text{mA}$
Reverse Current	I_R			20	μA	$V_R=1\text{V}$
Capacitance	C		20		pF	$V_R=0\text{V}$, $f=1\text{MHz}$

Note 1: Average power at 10MHz/50% duty cycle. Measured at the exit of 100m of fiber.

Note 2: 62.5/125μm graded index fiber (NA = 0.275).

Thermal Characteristics

Parameter	Symbol	Min.	Typ.	Max.	Units
Thermal Resistance - Infinite Heat Sink	R_{thjc}			200	°C/W
Thermal Resistance - On PCB	R_{thjb}			300	°C/W
Temperature Coefficient - Optical Power	dP/dT_j		-0.6		%/°C
Temperature Coefficient - Wavelength	$\Delta\lambda/dT_j$		0.3		nm/°C

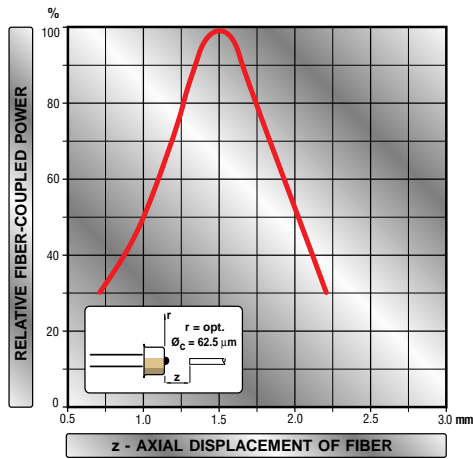

Figure 1

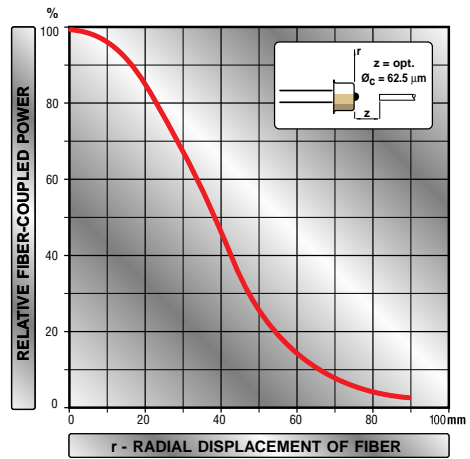

Figure 2

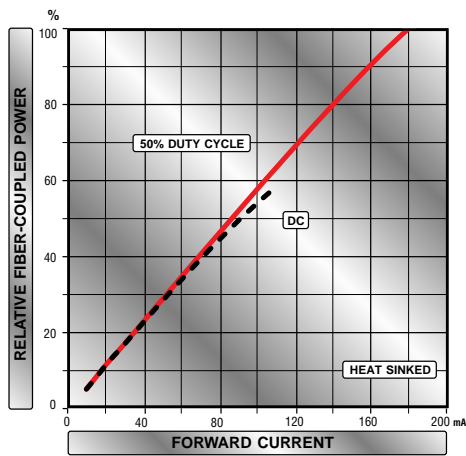

Figure 3

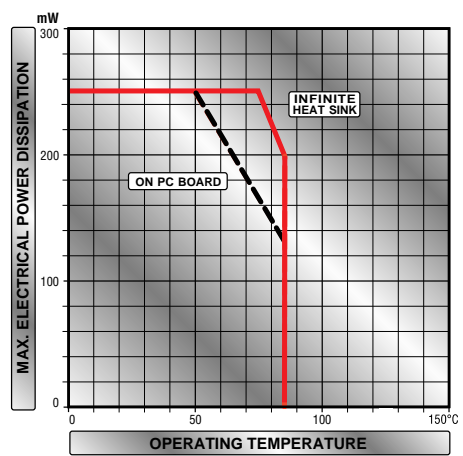

Figure 4

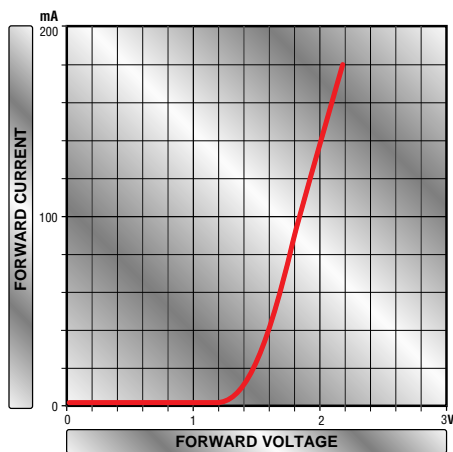
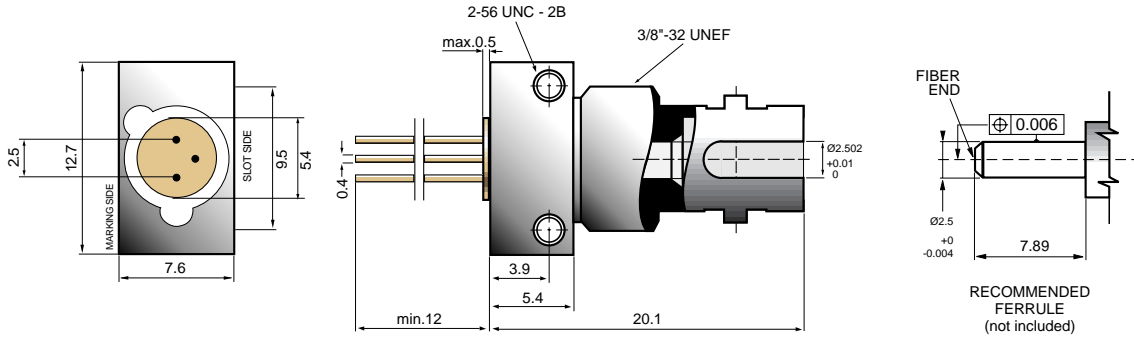

Figure 5

MF430 ST Mechanical Data



Note: The LED chip is isolated from the case. All dimensions in mm.

Typical Drive Circuit

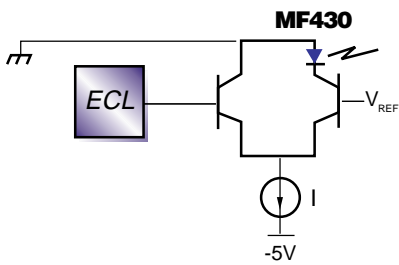

ST Packaging Hardware

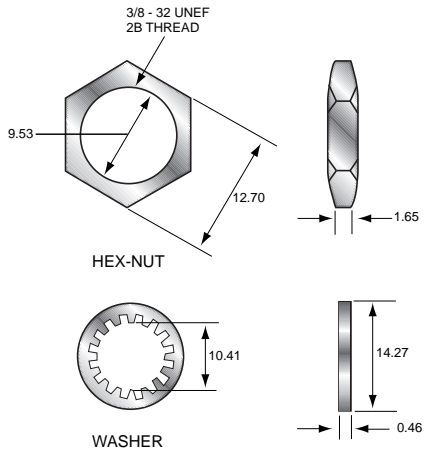



**For more information about all Zarlink products
visit our Web Site at
www.zarlink.com**

Information relating to products and services furnished herein by Zarlink Semiconductor Inc. trading as Zarlink Semiconductor or its subsidiaries (collectively "Zarlink") is believed to be reliable. However, Zarlink assumes no liability for errors that may appear in this publication, or for liability otherwise arising from the application or use of any such information, product or service or for any infringement of patents or other intellectual property rights owned by third parties which may result from such application or use. Neither the supply of such information or purchase of product or service conveys any license, either express or implied, under patents or other intellectual property rights owned by Zarlink or licensed from third parties by Zarlink, whatsoever. Purchasers of products are also hereby notified that the use of product in certain ways or in combination with Zarlink, or non-Zarlink furnished goods or services may infringe patents or other intellectual property rights owned by Zarlink.

This publication is issued to provide information only and (unless agreed by Zarlink in writing) may not be used, applied or reproduced for any purpose nor form part of any order or contract nor to be regarded as a representation relating to the products or services concerned. The products, their specifications, services and other information appearing in this publication are subject to change by Zarlink without notice. No warranty or guarantee express or implied is made regarding the capability, performance or suitability of any product or service. Information concerning possible methods of use is provided as a guide only and does not constitute any guarantee that such methods of use will be satisfactory in a specific piece of equipment. It is the user's responsibility to fully determine the performance and suitability of any equipment using such information and to ensure that any publication or data used is up to date and has not been superseded. Manufacturing does not necessarily include testing of all functions or parameters. These products are not suitable for use in any medical products whose failure to perform may result in significant injury or death to the user. All products and materials are sold and services provided subject to Zarlink's conditions of sale which are available on request.

Purchase of Zarlink's I²C components conveys a licence under the Philips I²C Patent rights to use these components in an I²C System, provided that the system conforms to the I²C Standard Specification as defined by Philips.

Zarlink and the Zarlink Semiconductor logo are trademarks of Zarlink Semiconductor Inc.

Copyright 2002, Zarlink Semiconductor Inc. All Rights Reserved.

TECHNICAL DOCUMENTATION - NOT FOR RESALE
