

ASYNCHRONOUS SRAM

128K x 16 SRAM

**+3.3V SUPPLY, SINGLE CHIP ENABLE
REVOLUTIONARY PINOUT**

FEATURES

- Fast access times: 10, 12, 15 and 20ns
- Fast OE# access times: 5, 6, 7 and 8ns
- Single +3.3V $\pm 0.3V$ power supply
- Fully static -- no clock or timing strobes necessary
- All inputs and outputs are TTL-compatible
- Three state outputs
- Center power and ground pins for greater noise immunity
- Easy memory expansion with CE# and OE# options
- Automatic CE# power down
- High-performance, low-power consumption, CMOS triple-poly, double-metal process
- Packaged in 44-pin, 400-mil SOJ and 44-pin, 400-mil TSOP

OPTIONS

- Timing

10ns access	-10
12ns access	-12
15ns access	-15
20ns access	-20
- Packages

44-pin SOJ (400 mil)	J
44-pin TSOP (400 mil)	TS
- Power consumption

Standard	None
Low	L
- Temperature

Commercial	None	(0°C to 70°C)
Industrial	I	(-40°C to 85°C)

MARKING

GENERAL DESCRIPTION

The GVT73128A16 is organized as a 131,072 x 16 SRAM using a four-transistor memory cell with a high performance, silicon gate, low-power CMOS process. Galvantech SRAMs are fabricated using triple-layer polysilicon, double-layer metal technology.

This device offers center power and ground pins for improved performance and noise immunity. Static design eliminates the need for external clocks or timing strobes. For increased system flexibility and eliminating bus contention problems, this device offers chip enable (CE#), separate byte enable controls (BLE# and BHE#) and output enable (OE#) with this organization.

The device offers a low power standby mode when chip is not selected. This allows system designers to meet low standby power requirements.

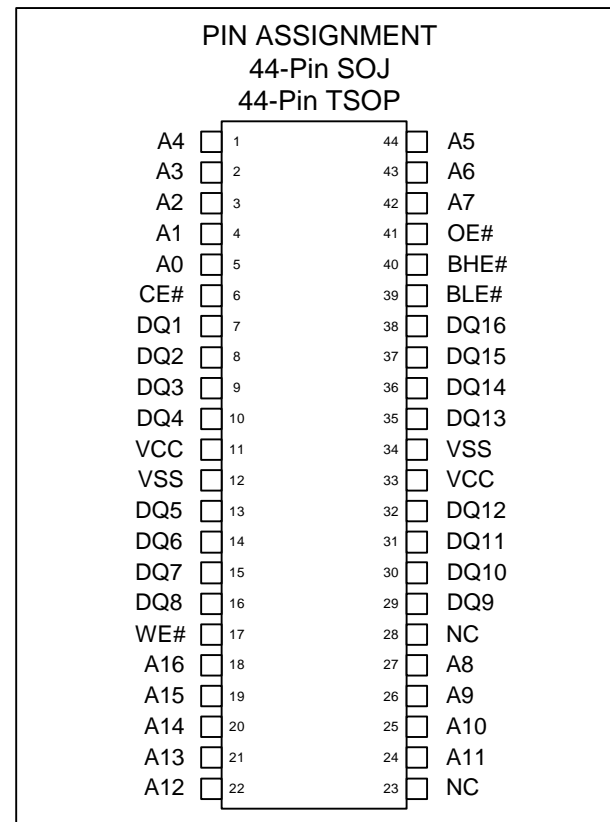

FUNCTIONAL BLOCK DIAGRAM

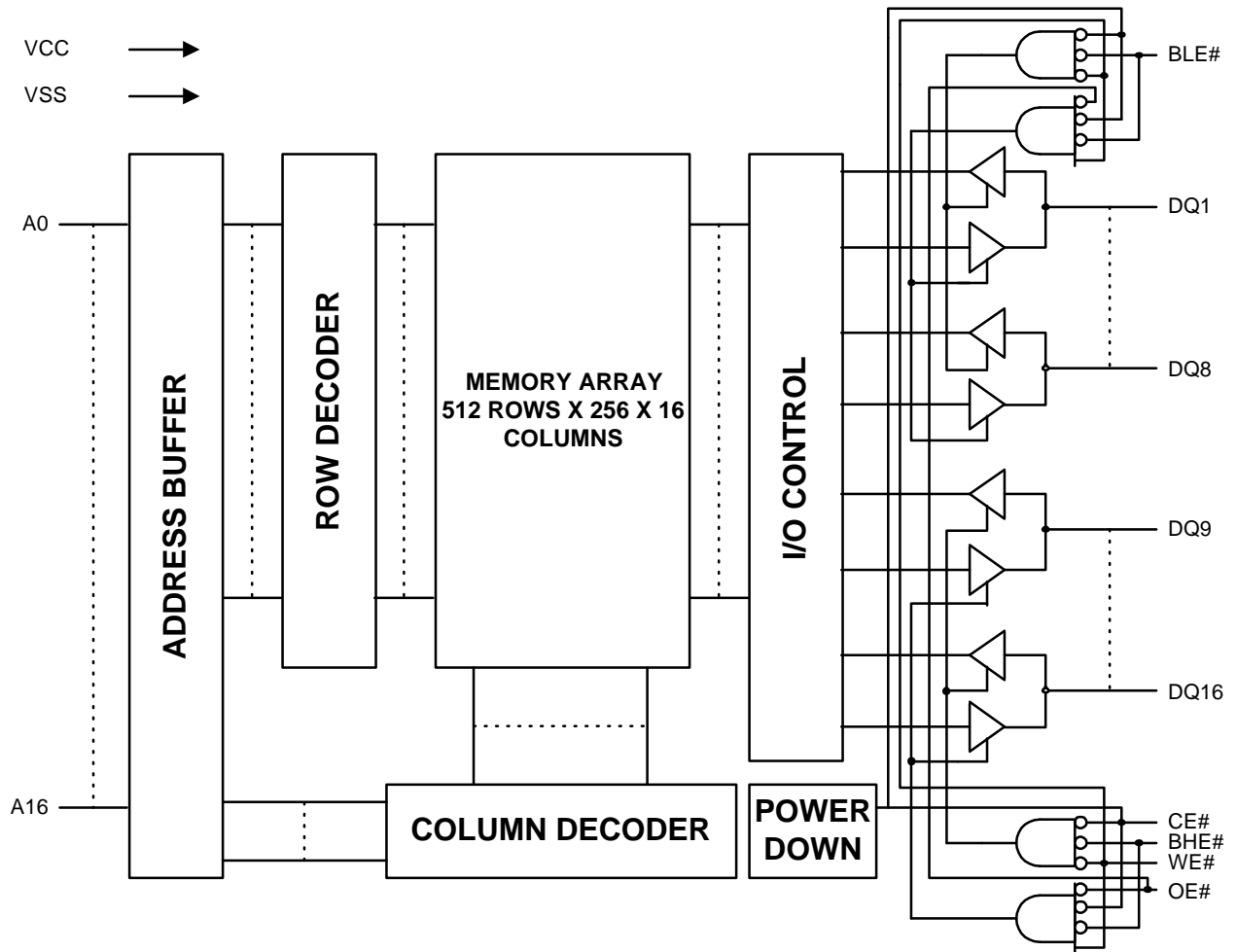

TRUTH TABLE

MODE	CE#	WE#	OE#	BLE#	BHE#	DQ1-DQ8	DQ9-DQ16	POWER
LOW BYTE READ (DQ1-DQ8)	L	H	L	L	H	Q	HIGH-Z	ACTIVE
HIGH BYTE READ (DQ9-DQ16)	L	H	L	H	L	HIGH-Z	Q	ACTIVE
WORD READ (DQ1-DQ16)	L	H	L	L	L	Q	Q	ACTIVE
LOW BYTE WRITE (DQ1-DQ8)	L	L	X	L	H	D	HIGH-Z	ACTIVE
HIGH BYTE WRITE (DQ9-DQ16)	L	L	X	H	L	HIGH-Z	D	ACTIVE
WORD WRITE (DQ1-DQ16)	L	L	X	L	L	D	D	ACTIVE
OUTPUT DISABLE	L	X	X	H	H	HIGH-Z	HIGH-Z	ACTIVE
	L	H	H	X	X	HIGH-Z	HIGH-Z	ACTIVE
STANDBY	H	X	X	X	X	HIGH-Z	HIGH-Z	STANDBY

PIN DESCRIPTIONS

SOJ & TSOP Pin Numbers	SYMBOL	TYPE	DESCRIPTION
5, 4, 3, 2, 1, 44, 43, 42, 27, 26, 25, 24, 22, 21, 20, 19, 18	A0-A16	Input	Addresses Inputs: These inputs determine which cell is addressed.
17	WE#	Input	Write Enable: This input determines if the cycle is a READ or WRITE cycle. WE# is LOW for a WRITE cycle and HIGH for a READ cycle.
6	CE#	Input	Chip Enable: This active LOW input is used to enable the device. When CE# is LOW, the chip is selected. When CE# is HIGH, the chip is disabled and automatically goes into standby power mode.
39, 40	BLE#, BHE#	Input	Byte Enable: These active LOW inputs allow individual bytes to be written or read. When BLE# is LOW, the data is written to or read from the lower byte (DQ1-DQ8). When BHE# is LOW, the data is written to or read from the higher byte (DQ9-DQ16).
41	OE#	Input	Output Enable: This active LOW input enables the output drivers.
7, 8, 9, 10, 13, 14, 15, 16, 29, 30, 31, 32, 35, 36, 37, 38	DQ1-DQ16	Input/Output	SRAM Data I/O: Data inputs and data outputs. Lower byte is DQ1-DQ8 and upper byte is DQ9-DQ16.
11, 33	VCC	Supply	Power Supply: 3.3V \pm 0.3V
12, 34	VSS	Supply	Ground

ABSOLUTE MAXIMUM RATINGS*

Voltage on VCC Supply Relative to VSS.....-0.5V to +4.6V
 V_{IN} -0.5V to VCC+1.0V
 Storage Temperature (plastic)-55°C to +125°
 Junction Temperature+125°
 Power Dissipation1.0W
 Short Circuit Output Current50mA

*Stresses greater than those listed under “Absolute Maximum Ratings” may cause permanent damage to the device. This is a stress rating only and functional operation of the device at these or any other conditions above those indicated in the operational sections of this specification is not implied. Exposure to absolute maximum rating conditions for extended periods may affect reliability.

DC ELECTRICAL CHARACTERISTICS AND RECOMMENDED OPERATING CONDITIONS
 (All Temperature Ranges; VCC = 3.3V ±0.3V unless otherwise noted)

DESCRIPTION	CONDITIONS	SYMBOL	MIN	MAX	UNITS	NOTES
Input High (Logic 1) voltage		V_{IH}	2.2	VCC+0.5	V	1, 2
Input Low (Logic 0) Voltage		V_{IL}	-0.5	0.8	V	1, 2
Input Leakage Current	$0V \leq V_{IN} \leq VCC$	IL_I	-5	5	uA	
Output Leakage Current	Output(s) disabled, $0V \leq V_{OUT} \leq VCC$	IL_O	-5	5	uA	
Output High Voltage	$I_{OH} = -4.0mA$	V_{OH}	2.4		V	1
Output Low Voltage	$I_{OL} = 8.0mA$	V_{OL}		0.4	V	1
Supply Voltage		VCC	3.0	3.6	V	1

DESCRIPTION	CONDITIONS	SYM	TYP	POWER	-10	-12	-15	-20	UNITS	NOTES
Power Supply Current: Operating	Device selected; CE# ≤ V_{IL} ; VCC = MAX; f=f _{MAX} ; outputs open	I _{CC}	70	standard	190	160	130	100	mA	3, 14
				low	180	150	120	90		
TTL Standby	CE# ≥ V_{IH} ; VCC = MAX; f=f _{MAX}	I _{SB1}	10	standard	35	30	25	20	mA	14
				low	30	25	20	15		
CMOS Standby	CE1# ≥ VCC - 0.2; VCC = MAX; all other inputs ≤ VSS + 0.2 or ≥ VCC - 0.2; all inputs static; f = 0	I _{SB2}	0.02	standard	3	3	3	3	mA	14
				low	0.3	0.3	0.3	0.3		

CAPACITANCE

DESCRIPTION	CONDITIONS	SYMBOL	MAX	UNITS	NOTES
Input Capacitance	$T_A = 25^\circ C$; f = 1 MHz VCC = 3.3V	C_I	6	pF	4
Input/Output Capacitance (DQ)		$C_{I/O}$	8	pF	4

AC ELECTRICAL CHARACTERISTICS(Note 5) (All Temperature Ranges; VCC = 3.3V \pm 0.3V)

DESCRIPTION	SYM	- 10		- 12		- 15		- 20		UNITS	NOTES
		MIN	MAX	MIN	MAX	MIN	MAX	MIN	MAX		
READ Cycle											
READ cycle time	^t RC	10		12		15		20		ns	
Address access time	^t AA		10		12		15		20	ns	
Chip Enable access time	^t ACE		10		12		15		20	ns	
Output hold from address change	^t OH	3		4		4		4		ns	
Chip Enable to output in Low-Z	^t LZCE	3		4		4		4		ns	4, 7
Chip disable to output in High-Z	^t HZCE		5		6		7		8	ns	4, 6, 7
Output Enable access time	^t AOE		5		6		7		8	ns	
Output Enable to output in Low-Z	^t LZOE	0		0		0		0		ns	
Output Enable to output in High-Z	^t HZOE		5		6		7		8	ns	4, 6
Byte Enable access time	^t ABE		6		7		8		9	ns	
Byte Enable to output in Low-Z	^t LZBE	0		0		0		0		ns	4, 7
Byte disable to output in High-Z	^t HZBE		5		6		7		8	ns	4, 6, 7
Chip Enable to power-up time	^t PU	0		0		0		0		ns	4
Chip disable to power-down time	^t PD		10		12		15		20	ns	4
WRITE Cycle											
WRITE cycle time	^t WC	10		12		15		20		ns	
Chip Enable to end of write	^t CW	8		8		9		10		ns	
Address valid to end of write, with OE# HIGH	^t AW	8		8		9		10		ns	
Address setup time	^t AS	0		0		0		0		ns	
Address hold from end of write	^t AH	0		0		0		0		ns	
WRITE pulse width	^t WP2	10		10		11		12		ns	
WRITE pulse width, with OE# HIGH	^t WP1	8		8		9		10		ns	
Data setup time	^t DS	5		6		7		8		ns	
Data hold time	^t DH	0		0		0		0		ns	
Write disable to output in Low-Z	^t LZWE	3		4		5		5		ns	4, 7
Write Enable to output in High-Z	^t HZWE		5		6		7		8	ns	4, 6, 7
Byte Enable to end of write	^t BW	8		8		9		10		ns	

AC TEST CONDITIONS

Input pulse levels	0V to 3.0V
Input rise and fall times	1.5ns
Input timing reference levels	1.5V
Output reference levels	1.5V
Output load	See Figures 1 and 2

OUTPUT LOADS

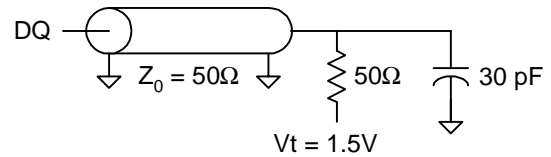

Fig. 1 OUTPUT LOAD EQUIVALENT

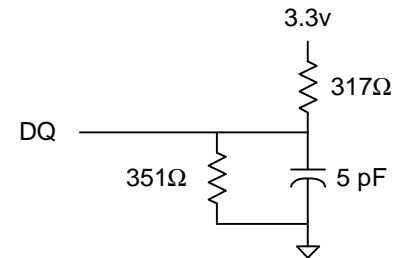

Fig. 2 OUTPUT LOAD EQUIVALENT

NOTES

- All voltages referenced to VSS (GND).
- Overshoot: $V_{IH} \leq +6.0V$ for $t \leq t_{RC} / 2$.
Undershoot: $V_{IL} \leq -2.0V$ for $t \leq t_{RC} / 2$
- I_{cc} is given with no output current. I_{cc} increases with greater output loading and faster cycle times.
- This parameter is sampled.
- Test conditions as specified with the output loading as shown in Fig. 1 unless otherwise noted.
- Output loading is specified with $C_L = 5pF$ as in Fig. 2. Transition is measured $\pm 500mV$ from steady state voltage.
- At any given temperature and voltage condition, t_{HZCE} is less than t_{LZCE} and t_{HZWE} is less than t_{LZWE} .
- WE# is HIGH for READ cycle.
- Device is continuously selected. Chip enable and output enables are held in their active state.
- Address valid prior to, or coincident with, latest occurring chip enable.
- t_{RC} = Read Cycle Time.
- Chip Enable and Write Enable can initiate and terminate a WRITE cycle.
- Capacitance derating applies to capacitance different from the load capacitance shown in Fig. 1.
- Typical values are measured at 3.3V, 25°C and 20ns cycle time.

DATA RETENTION ELECTRICAL CHARACTERISTICS (L Version Only)

DESCRIPTION	CONDITIONS	SYMBOL	MIN	TYP	MAX	UNITS	NOTES
Vcc for Retention Data		V_{DR}	2			V	
Data Retention Current	CE# $\geq V_{CC} - 0.2$; all other inputs $\leq V_{SS} + 0.2$ or $\geq V_{CC} - 0.2$; all inputs static; f = 0	Vcc = 2V	I_{CCDR}	2	100	uA	13
		Vcc = 3V	I_{CCDR}		3	150	uA
Chip Deselect to Data Retention Time		t_{CDR}	0			ns	4
Operation Recovery Time		t_R	t_{RC}			ns	4, 11

LOW VCC DATA RETENTION WAVEFORM

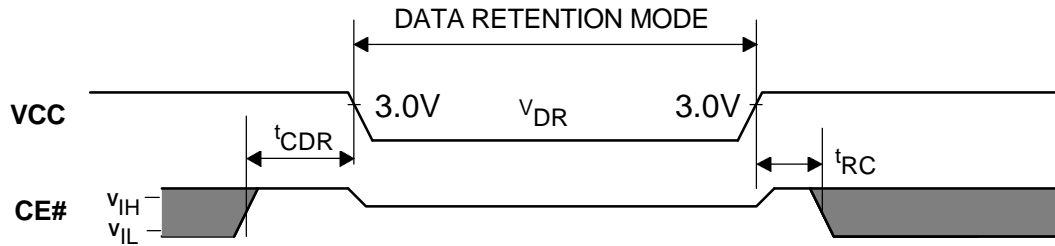

READ CYCLE NO. 1^(8,9)

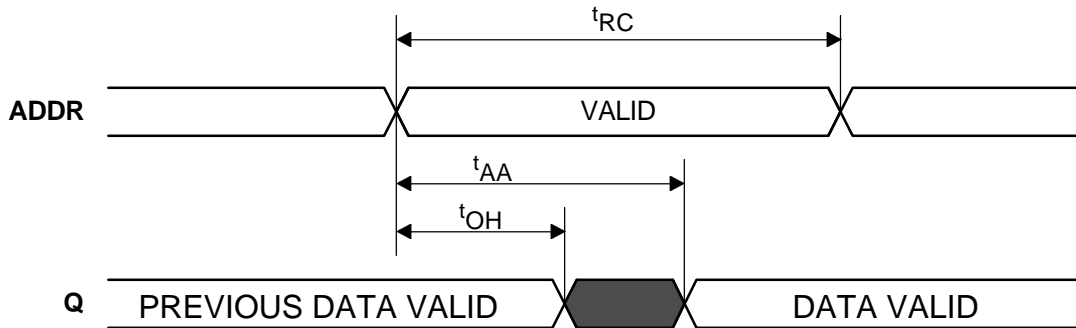

READ CYCLE NO. 2^(7,8,10,12)

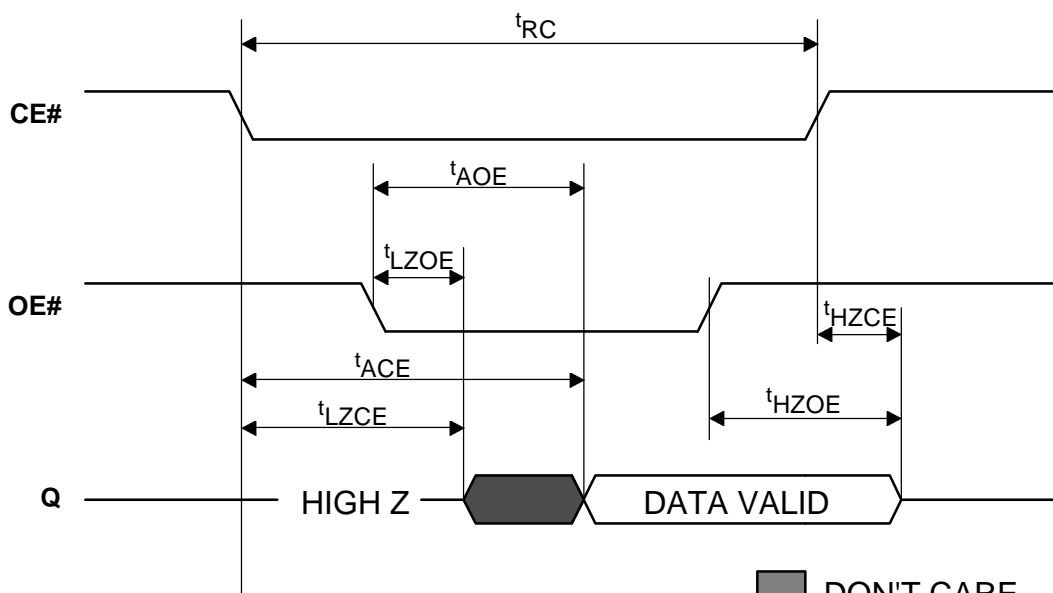

■ DON'T CARE
■ UNDEFINED

WRITE CYCLE NO. 1 ^(7, 12, 13)

(Write Enable Controlled with Output Enable OE# active LOW)

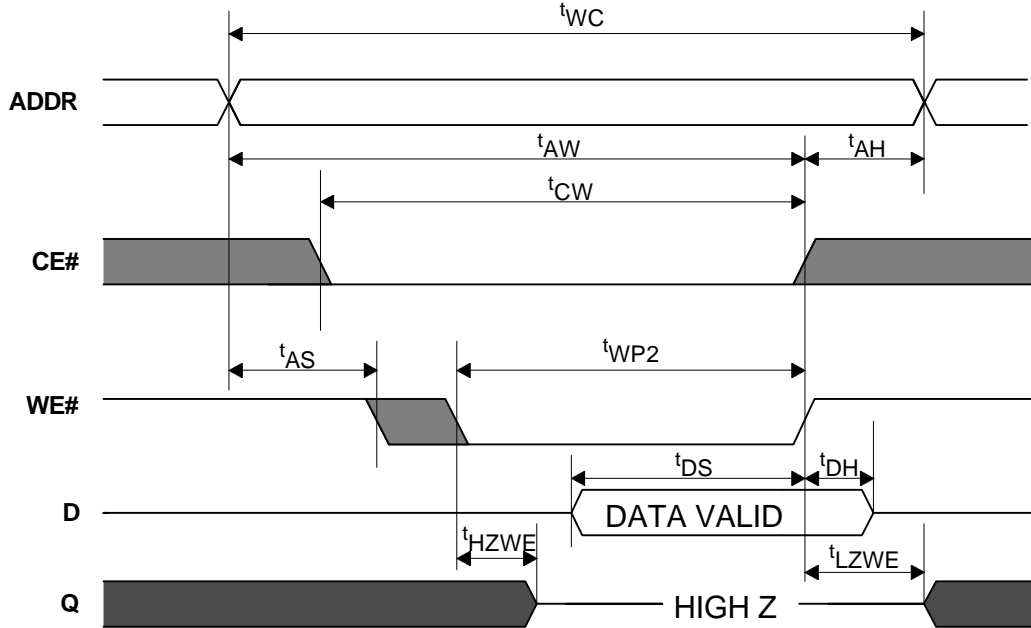

WRITE CYCLE NO. 2 ^(12, 13)

(Write Enable Controlled with Output Enable OE# inactive HIGH)

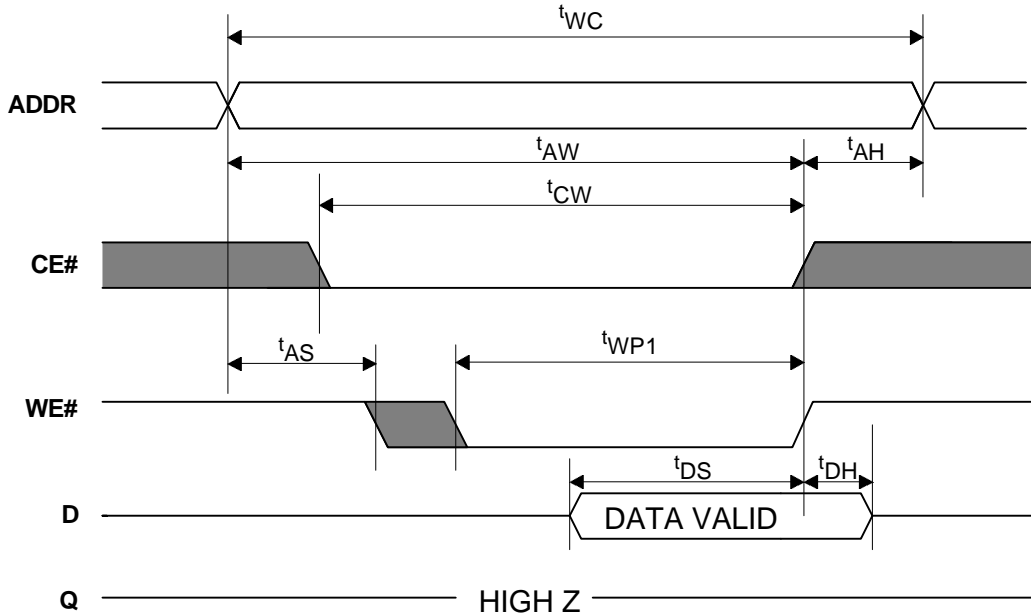

■ DON'T CARE
■ UNDEFINED

WRITE CYCLE NO. 3^(12, 13)
(Chip Enable Controlled)

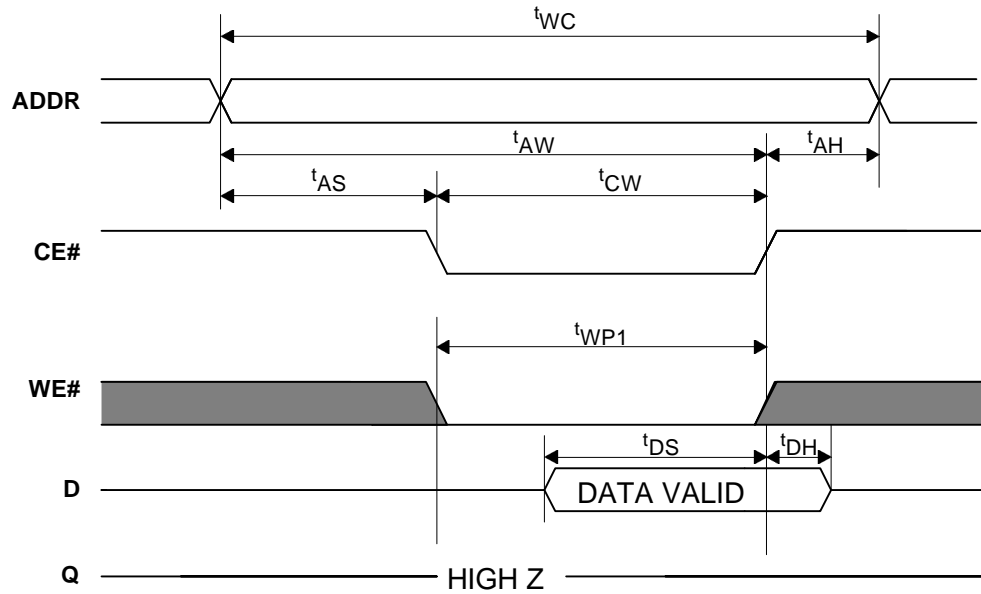

WRITE CYCLE NO. 4^(12, 13)
(Byte Enable Controlled)

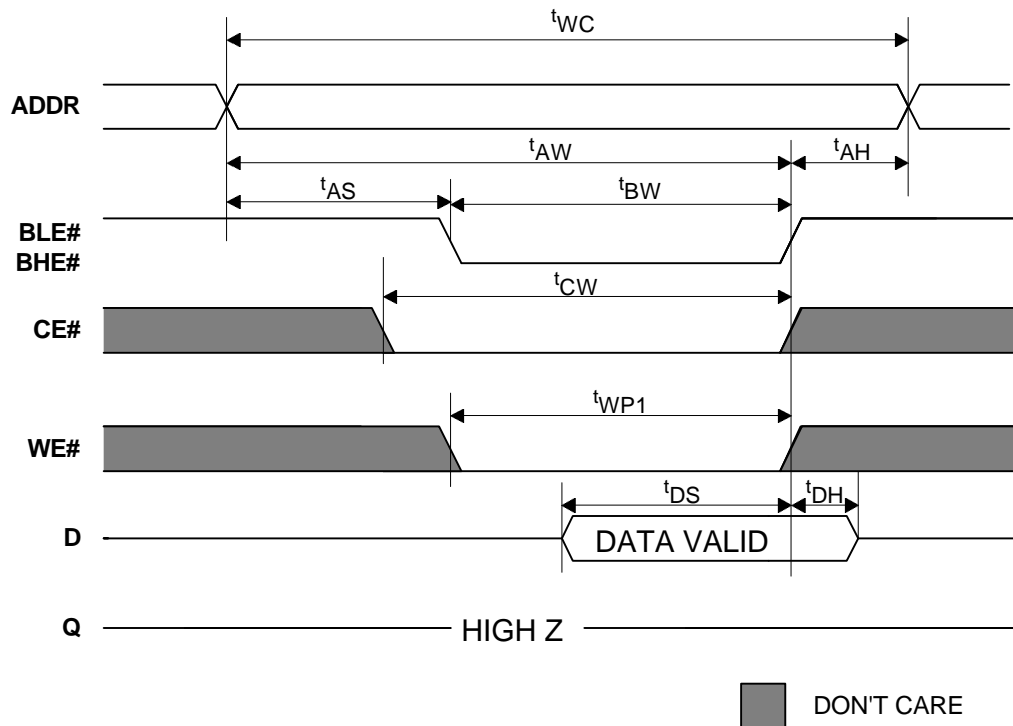

Package Dimensions

44-pin 400 Mil Plastic SOJ (J)

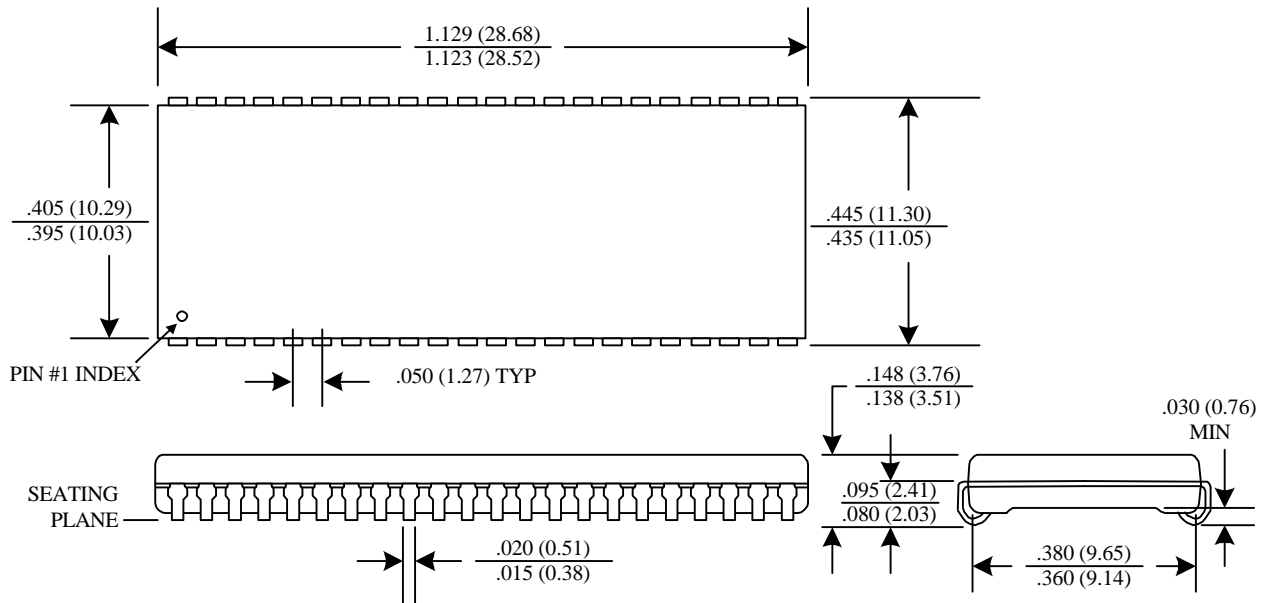

Note: All dimensions in inches (millimeters) $\frac{\text{MAX}}{\text{MIN}}$ or typical, min where noted.

44-pin 400 Mil Plastic TSOP (TS)

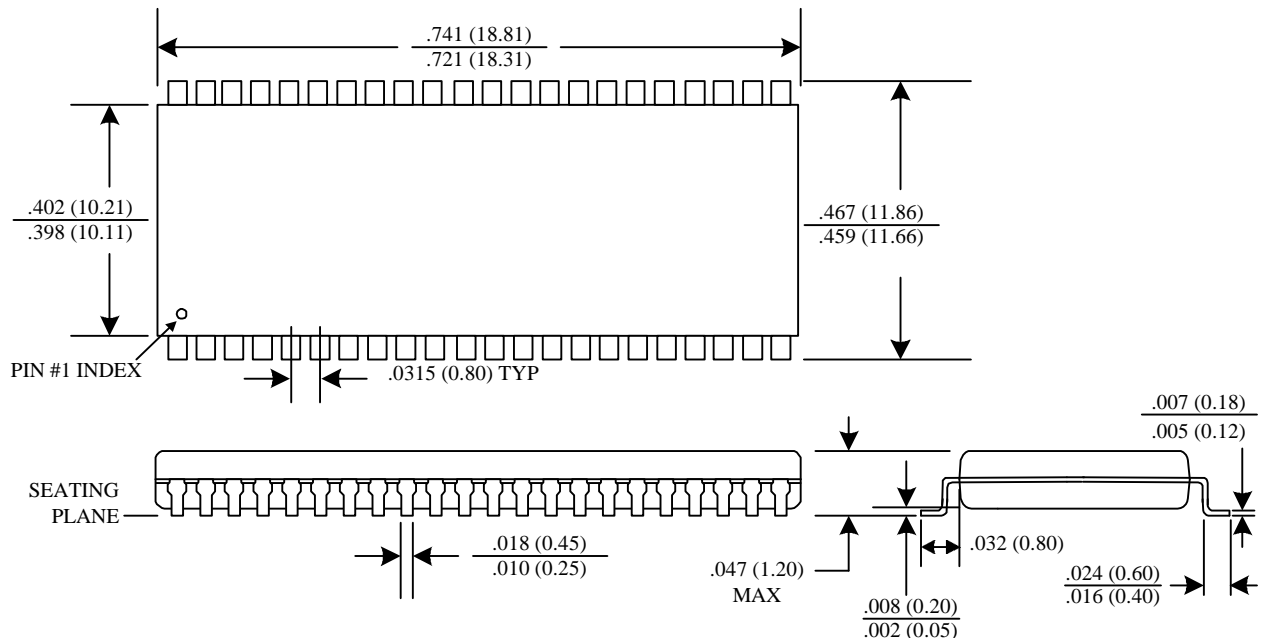

Note: All dimensions in inches (millimeters) $\frac{\text{MAX}}{\text{MIN}}$ or typical, max where noted.

Ordering Information

GVT 73128A16 XX - XX X X

Galvantech Prefix

Part Number

Temperature (Blank = Commercial
I = Industrial)

Power (Blank= Standard,
L= Low Power)

Speed (10 = 10ns, 12 = 12ns
15 = 15ns, 20 = 20ns)

Package (J = 400 mil SOJ,
TS = TSOP TYPE II)