

TOSHIBA POWER TRANSISTOR MODULE SILICON NPN & PNP EPITAXIAL TYPE (DARLINGTON POWER TRANSISTOR 4 IN 1)

MP4503

HIGH POWER SWITCHING APPLICATIONS.

HAMMER DRIVE, PULSE MOTOR DRIVE AND INDUCTIVE LOAD SWITCHING.

INDUSTRIAL APPLICATIONS

Unit in mm

- Package with Heat Sink Isolated to Lead (SIP 12 Pin)
- High Collector Power Dissipation (4 Devices Operation)
: $P_T = 5W$ ($T_a = 25^\circ C$)
- High Collector Current : $I_C (DC) = \pm 4A$ (Max.)
- High DC Current Gain : $h_{FE} = 2000$ (Min.)
($V_{CE} = \pm 2V, I_C = \pm 1A$)

MAXIMUM RATINGS ($T_a = 25^\circ C$)

CHARACTERISTIC	SYMBOL	RATING		UNIT	
		NPN	PNP		
Collector-Base Voltage	V_{CBO}	100	-100	V	
Collector-Emitter Voltage	V_{CEO}	80	-80	V	
Emitter-Base Voltage	V_{EBO}	5	-5	V	
Collector Current	DC	I_C	4	-4	A
	Pulse	I_{CP}	6	-6	
Continuous Base Current	I_B	0.4	-0.4	A	
Collector Power Dissipation (1 Device Operation)	P_C	3.0		W	
Collector Power Dissipation (4 Devices Operation)	$T_a = 25^\circ C$	P_T	5.0		W
	$T_c = 25^\circ C$		25		
Isolation Voltage	V_{Isol}	1000		V	
Junction Temperature	T_j	150		$^\circ C$	
Storage Temperature Range	T_{stg}	-55~150		$^\circ C$	

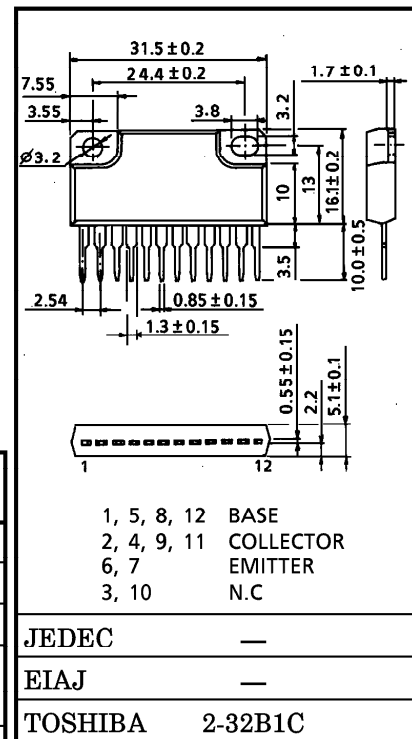

Weight : 6.0g

961001EAA2

- TOSHIBA is continually working to improve the quality and the reliability of its products. Nevertheless, semiconductor devices in general can malfunction or fail due to their inherent electrical sensitivity and vulnerability to physical stress. It is the responsibility of the buyer, when utilizing TOSHIBA products, to observe standards of safety, and to avoid situations in which a malfunction or failure of a TOSHIBA product could cause loss of human life, bodily injury or damage to property. In developing your designs, please ensure that TOSHIBA products are used within specified operating ranges as set forth in the most recent products specifications. Also, please keep in mind the precautions and conditions set forth in the TOSHIBA Semiconductor Reliability Handbook.
- The information contained herein is presented only as a guide for the applications of our products. No responsibility is assumed by TOSHIBA CORPORATION for any infringements of intellectual property or other rights of the third parties which may result from its use. No license is granted by implication or otherwise under any intellectual property or other rights of TOSHIBA CORPORATION or others.
- The information contained herein is subject to change without notice.

ARRAY CONFIGURATION

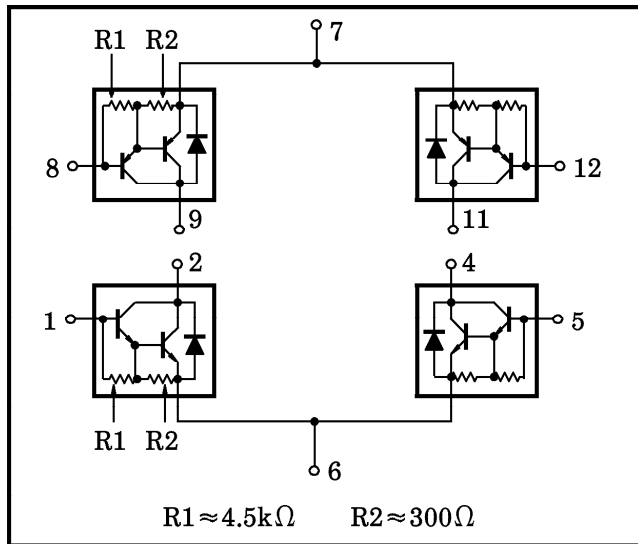

THERMAL CHARACTERISTICS

CHARACTERISTIC	SYMBOL	MAX.	UNIT
Thermal Resistance of Junction to Ambient (4 Devices Operation, $T_a = 25^\circ\text{C}$)	$\Sigma R_{th(j-a)}$	25	$^\circ\text{C} / \text{W}$
Thermal Resistance of Junction to Case (4 Devices Operation, $T_c = 25^\circ\text{C}$)	$\Sigma R_{th(j-c)}$	5.0	$^\circ\text{C} / \text{W}$
Maximum Lead Temperature for Soldering Purposes (3.2mm from Case for 10s)	T_L	260	$^\circ\text{C}$

ELECTRICAL CHARACTERISTICS (Ta = 25°C) (NPN TRANSISTOR)

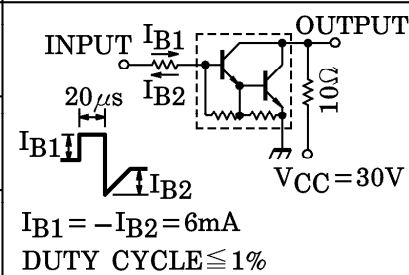
CHARACTERISTIC		SYMBOL	TEST CONDITION	MIN.	TYP.	MAX.	UNIT
Collector Cut-off Current		ICBO	V _{CB} = 100V, I _E = 0	—	—	20	μA
Collector Cut-off Current		ICEO	V _{CE} = 80V, I _B = 0	—	—	20	μA
Emitter Cut-off Current		IEBO	V _{EB} = 5V, I _C = 0	0.5	—	2.5	mA
Collector-Base Breakdown Voltage		V _{(BR)CBO}	I _C = 1mA, I _E = 0	100	—	—	V
Collector-Emitter Breakdown Voltage		V _{(BR)CEO}	I _C = 10mA, I _B = 0	80	—	—	V
DC Current Gain		h _{FE} (1)	V _{CE} = 2V, I _C = 1A	2000	—	—	
		h _{FE} (2)	V _{CE} = 2V, I _C = 3A	1000	—	—	
Saturation Voltage	Collector-Emitter	V _{CE(sat)}	I _C = 3A, I _B = 6mA	—	—	1.5	V
	Base-Emitter	V _{BE(sat)}	I _C = 3A, I _B = 6mA	—	—	2.0	
Transition Frequency		f _T	V _{CE} = 2V, I _C = 0.5A	—	60	—	MHz
Collector Output Capacitance		C _{ob}	V _{CB} = 10V, I _E = 0, f = 1MHz	—	30	—	pF
Switching Time	Turn-on Time	t _{on}	 <p>I_{B1} = -I_{B2} = 6mA DUTY CYCLE ≤ 1%</p>	—	0.2	—	μs
	Storage Time	t _{stg}		—	1.5	—	
	Fall Time	t _f		—	0.6	—	

EMITTER-COLLECTOR DIODE RATINGS AND CHARACTERISTICS (Ta = 25°C)

CHARACTERISTIC	SYMBOL	TEST CONDITION	MIN.	TYP.	MAX.	UNIT
Forward Current	I _{FM}	—	—	—	4	A
Surge Current	I _{FSM}	t = 1s, 1 shot	—	—	6	A
Forward Voltage	V _F	I _F = 1A, I _B = 0	—	—	2.0	V
Reverse Recovery Time	t _{rr}	I _F = 4A, V _{BE} = -3V,	—	1.0	—	μs
Reverse Recovery Charge	Q _{rr}	dI _F / dt = -50A / μs	—	8	—	μC

ELECTRICAL CHARACTERISTICS (Ta = 25°C) (PNP TRANSISTOR)

CHARACTERISTIC		SYMBOL	TEST CONDITION	MIN.	TYP.	MAX.	UNIT
Collector Cut-off Current		ICBO	V _{CB} = -100V, I _E = 0	—	—	-20	μA
Collector Cut-off Current		ICEO	V _{CE} = -80V, I _B = 0	—	—	-20	μA
Emitter Cut-off Current		IEBO	V _{EB} = -5V, I _C = 0	-0.5	—	-2.5	mA
Collector-Base Breakdown Voltage		V _{(BR)CBO}	I _C = -1mA, I _E = 0	-100	—	—	V
Collector-Emitter Breakdown Voltage		V _{(BR)CEO}	I _C = -10mA, I _B = 0	-80	—	—	V
DC Current Gain		h _{FE} (1)	V _{CE} = -2V, I _C = -1A	2000	—	—	
		h _{FE} (2)	V _{CE} = -2V, I _C = -3A	1000	—	—	
Saturation Voltage	Collector-Emitter	V _{CE(sat)}	I _C = -3A, I _B = -6mA	—	—	-1.5	V
	Base-Emitter	V _{BE(sat)}	I _C = -3A, I _B = -6mA	—	—	-2.0	
Transition Frequency		f _T	V _{CE} = -2V, I _C = -0.5A	—	40	—	MHz
Collector Output Capacitance		C _{ob}	V _{CB} = -10V, I _E = 0, f = 1MHz	—	55	—	pF
Switching Time	Turn-on Time	t _{on}		—	0.15	—	μs
	Storage Time	t _{stg}		—	0.80	—	
	Fall Time	t _f		-I _{B1} = I _{B2} = 6mA, DUTY CYCLE ≤ 1%	—	0.40	

EMITTER-COLLECTOR DIODE RATINGS AND CHARACTERISTICS (Ta = 25°C)

CHARACTERISTIC	SYMBOL	TEST CONDITION	MIN.	TYP.	MAX.	UNIT
Forward Current	I _{FM}	—	—	—	4	A
Surge Current	I _{FSM}	t = 1s, 1 shot	—	—	6	A
Forward Voltage	V _F	I _F = 1A, I _B = 0	—	—	2.0	V
Reverse Recovery Time	t _{rr}	I _F = 4A, V _{BE} = 3V,	—	1.0	—	μs
Reverse Recovery Charge	Q _{rr}	dI _F / dt = -50A / μs	—	8	—	μC

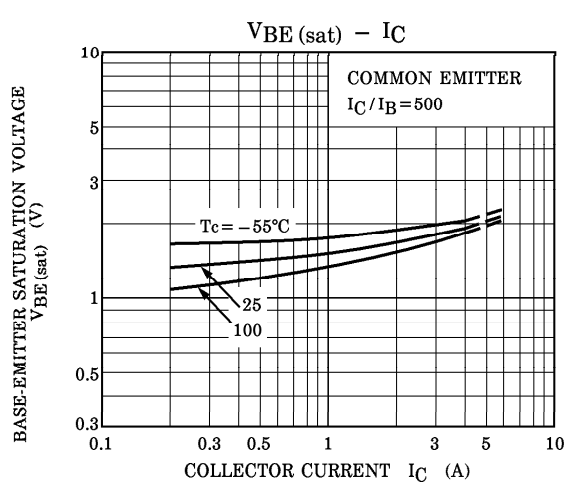
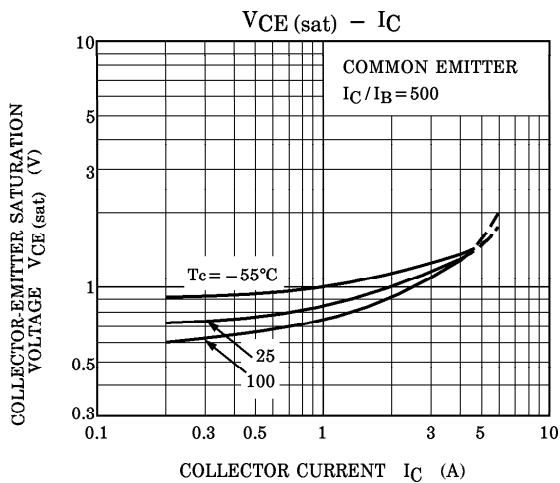
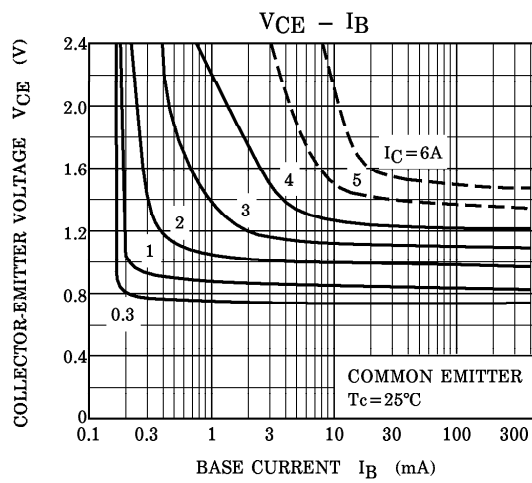
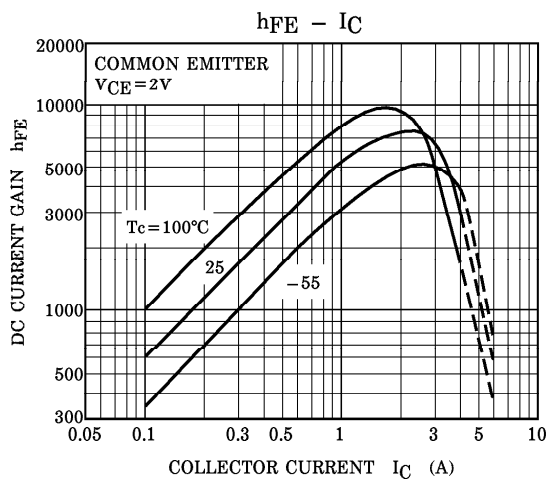
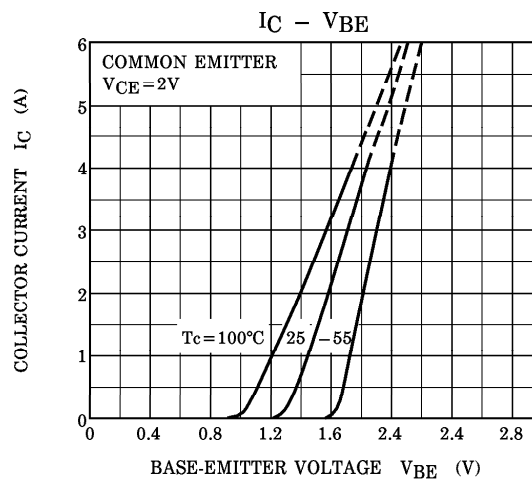
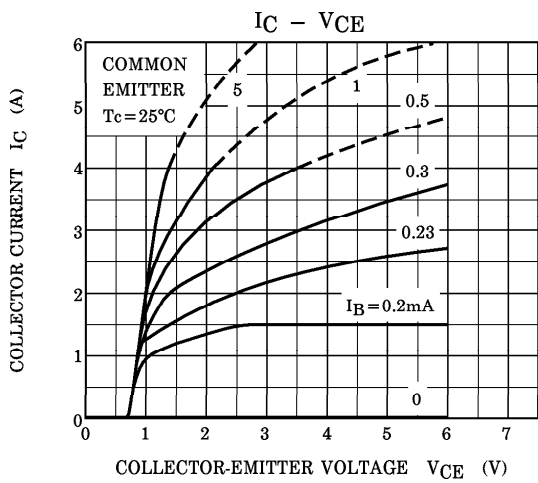

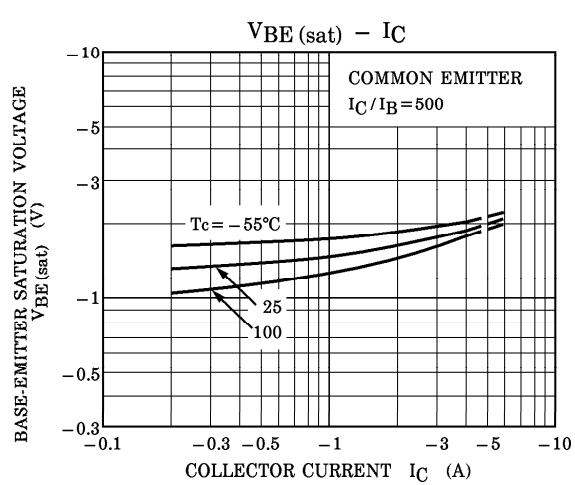
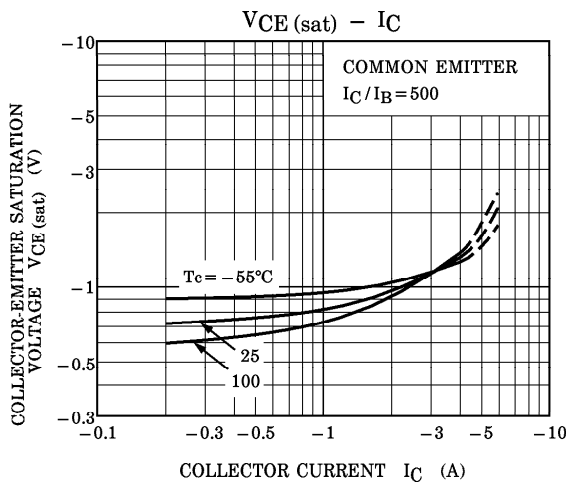
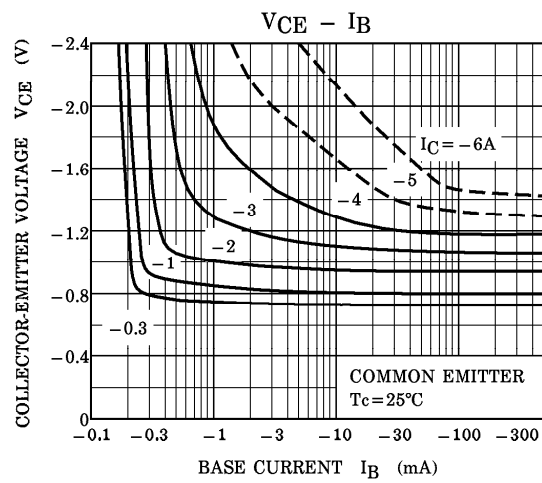
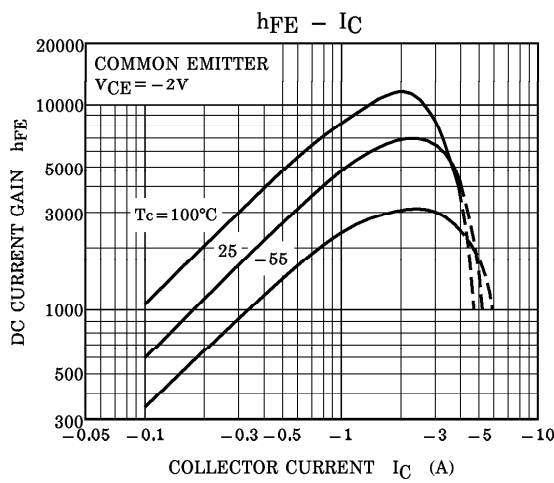
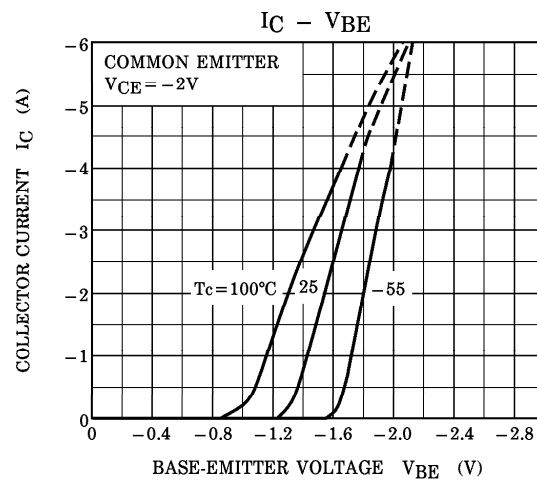
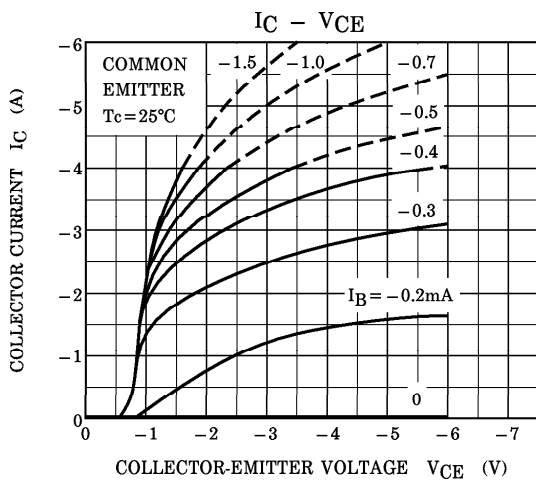

SAFE OPERATING AREA (NPN Tr)

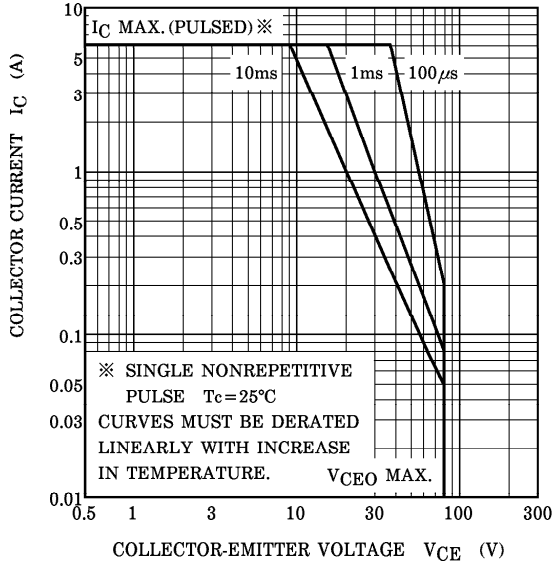

SAFE OPERATING AREA (PNP Tr)

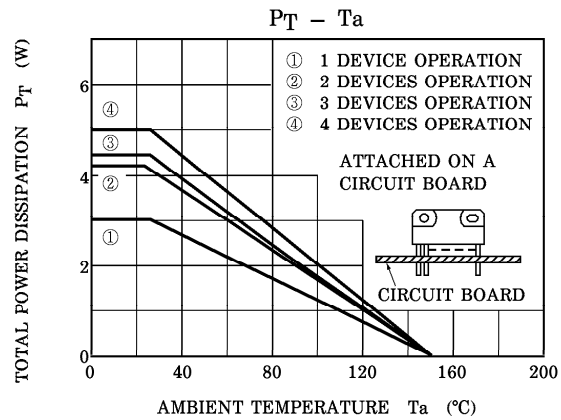
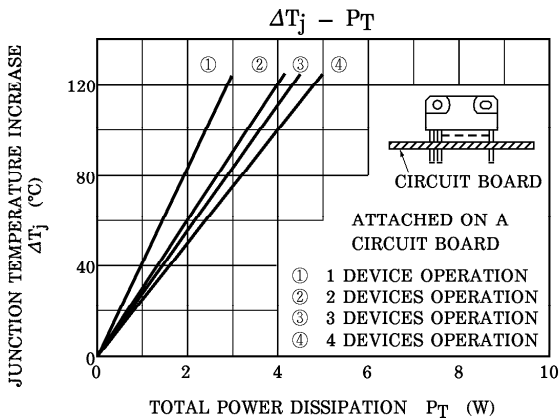
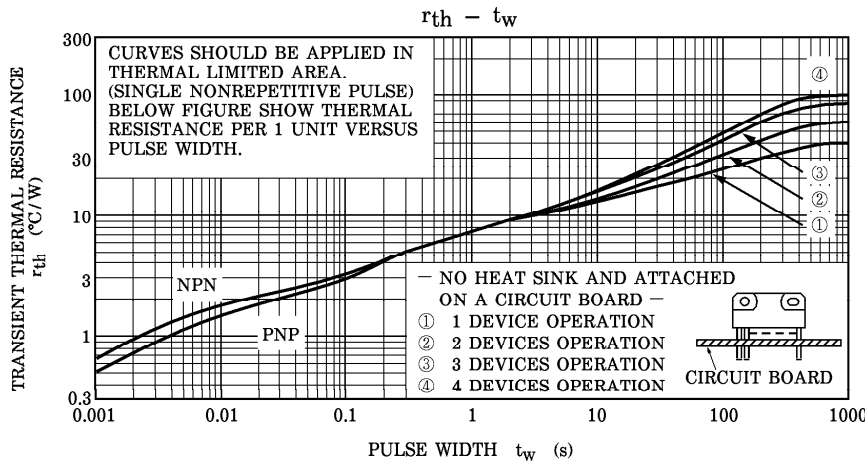
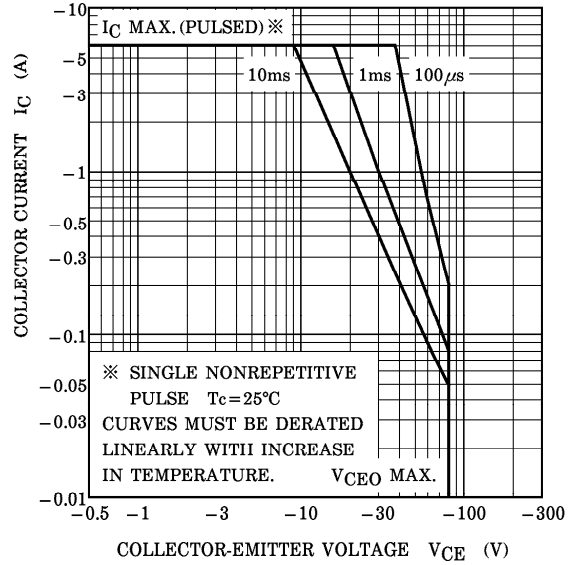

スイッチング特性 (NPN)

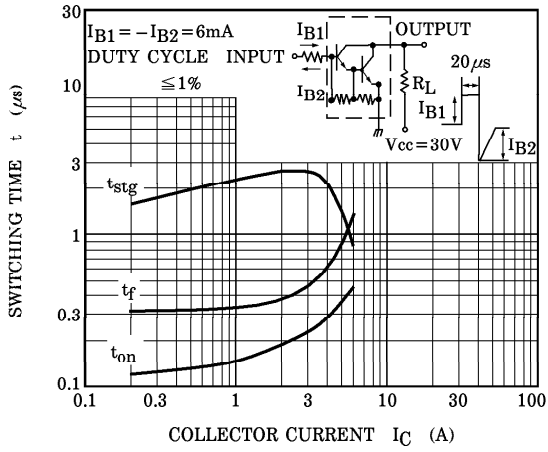

スイッチング特性 (PNP)

